



INSTALLATION GUIDE

UNIVERSAL FOLD DOWN TABLE

UN1109B



TOOLS REQUIRED (NOT INCLUDED)

- | | |
|------------------|--------------------------|
| + RATCHET | + 7/16" WRENCH OR SOCKET |
| + MEASURING TAPE | + 5/32" ALLEN WRENCH |
| + MARKER | + 10MM WRENCH |

INSTALL INFO

TIME TO INSTALL THIS PRODUCT: 30-45 MINUTES

Additional help is suggested for a few of the install steps.
Compatible with all FVC Rear Door Platforms.

BEFORE YOU START

Please inspect the product and packaging upon delivery to ensure there are no issues and that all parts and hardware are accounted for.

Contact us ASAP if anything is missing at:
support@flatlinevanco.com

BEFORE YOU START

All Flatline Van Co products must be properly assembled and secured before attaching to your vehicle. Improper attachment could result in an automobile accident, and could cause serious bodily injury or death to you or to others involved. You are responsible for assembling and securing Flatline Van Co products to your vehicle, checking the mounting points and attachments prior to use, and regularly inspecting the products for wear and or damage. We always recommend you use a professional to install any aftermarket accessories to your vehicle. If you have no mechanical experience and are not thoroughly familiar with the installation procedures, you must have the product installed by a professional installer or other qualified persons. The responsibility is yours and must be taken seriously for everyone's safety.



PACKAGE CONTENTS

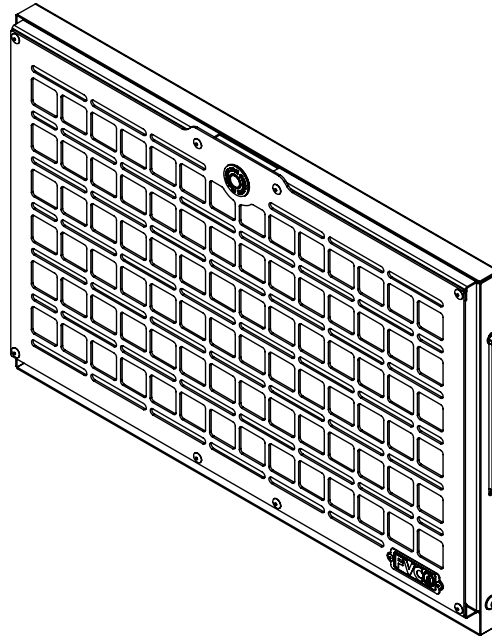

FOLD DOWN TABLE

QTY: 1

HARDWARE

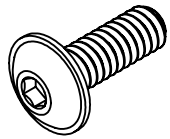

1/4-20 X0.75 FLANGED
BUTTON HEAD SCREW

QTY: 4

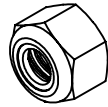

1/4-20 NYLON INSERT
LOCKNUT

QTY: 4



1/4 SCREW FLAT WASHER

QTY: 4

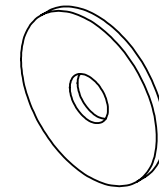

1/4 OVERSIZED FLAT
WASHER

QTY: 4

INSTALL

STEP | 01 LAYOUT & INSTALL PREP

The **Fold Down Table** is designed to be compatible with **FVC Rear Door Products** (Rear Door Molle Panels, Platforms, Storage Boxes) but can be modified for installation with other rear door accessory systems.

The table comes pre-assembled from the factory and ready to bolt on. Find the hardware pack and familiarize yourself with the contents.

1.1 Dry fit the table to your mounting surface and determine the desired height of install. If you'd rather measure, see **FIG 1** for the overall dimensions and distances between the mounting points.

1.2 If you are using a product other than an FVC Rear Door Product, mark the back of the table to match your available mounting points and drill out (4) 1/4" holes accordingly.

PRO-TIP: Masking tape can also be used to mark desired install height.

NOTE - Modifying your Fold Down Table for mounting to products other than **FVC Rear Door Products** is done **at your own risk**. If you don't feel comfortable installing this on your own, see our **Find a Builder or Upfitter** page to locate an approved installer near you.

TOOLS REQUIRED FOR THIS STEP: + MEASURING TAPE
+ MARKER

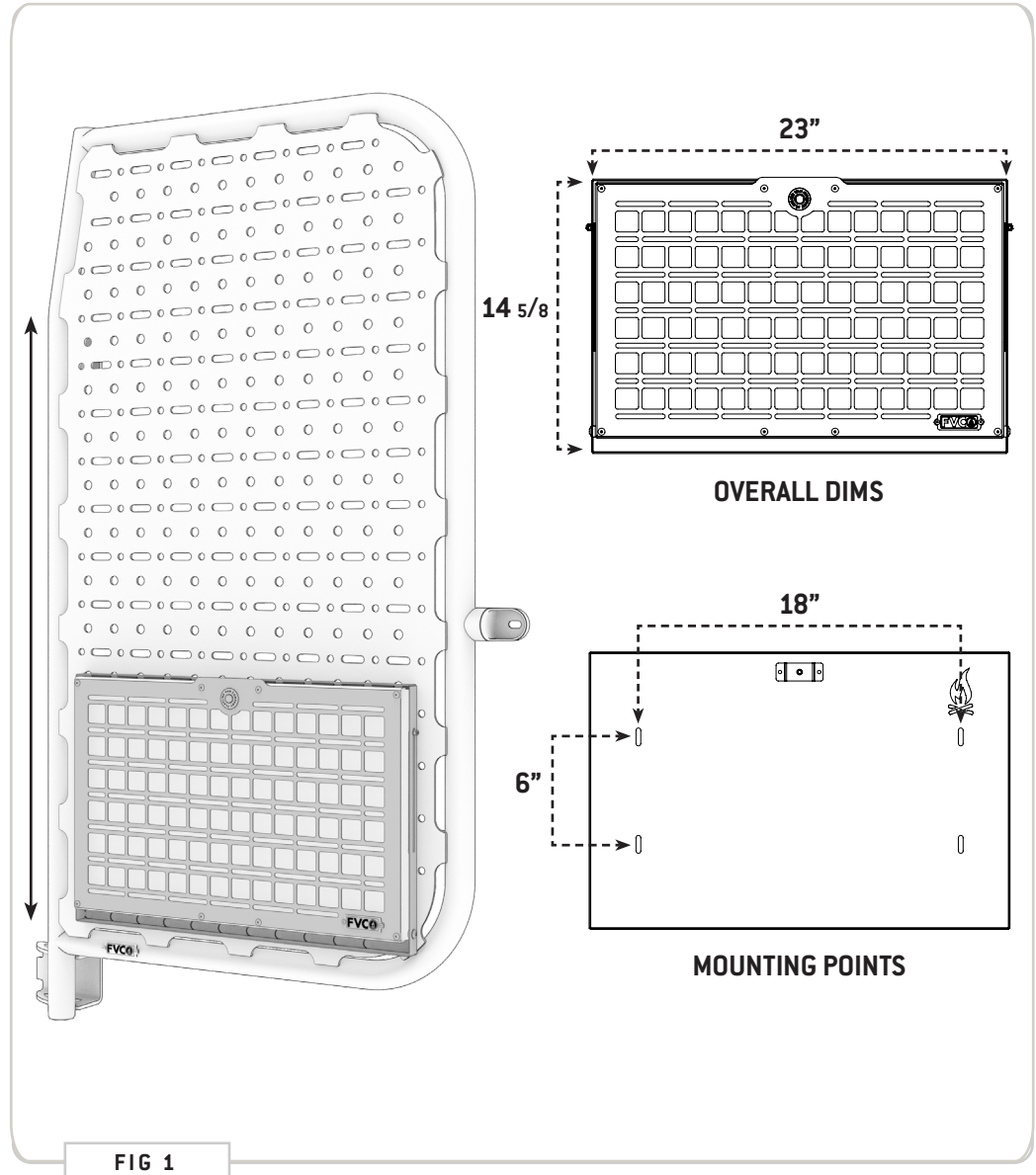

TOOLS REQUIRED FOR THIS STEP:

STEP | 02 FOLD DOWN TABLE INSTALL

2.1 Use the **Push Button** to open the **Fold Down Table** to access the mounting holes (FIG 2).



FIG 2

- TOOLS REQUIRED FOR THIS STEP:**
- + 5/32" ALLEN WRENCH
 - + RATCHET
 - + 7/16" WRENCH OR SOCKET

STEP | 02 FOLD DOWN TABLE INSTALL

2.2 Insert (1ea) 1/4-20 x 0.75" Flanged Hex Head Screws to the upper mounting holes (FIG 3).

2.3 With help, lift and align top holes with hardware to the desired mounting location.

2.4 Reaching around the mounting surface, attach (1ea) 1/4" Flat Washers and 1/4" Oversized Flat Washers to the bolt and loosely thread on (1ea) 1/4" Nylon Lock Nuts to hold the table in place. (FIG 4)

2.5 Repeat this process on the lower mounting holes.

2.6 Verify positioning and tighten down hardware.



FIG 3

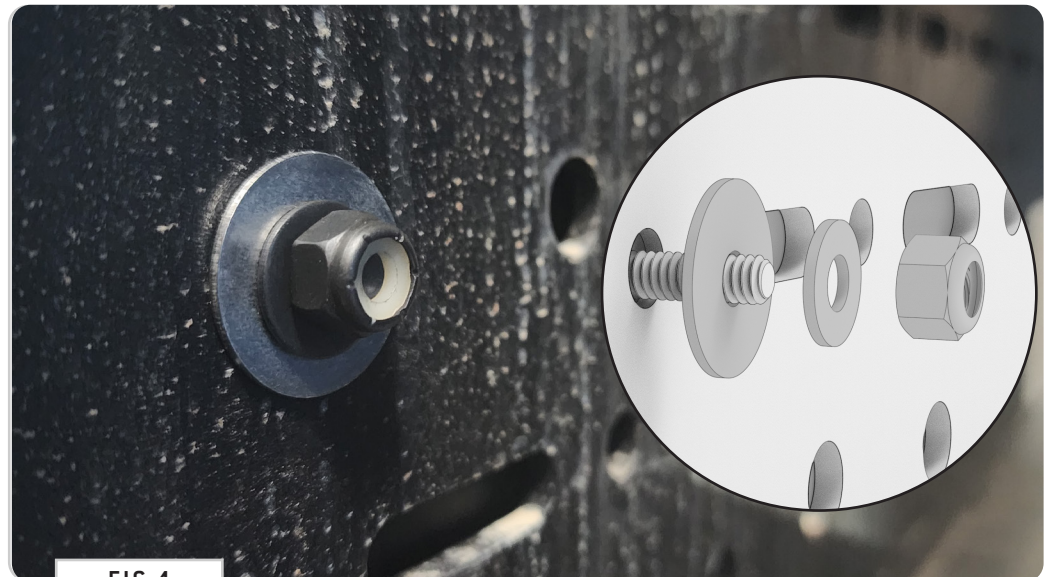

FIG 4

TOOLS REQUIRED FOR THIS STEP: + 10MM WRENCH

STEP | 03 FOLD DOWN TABLE ADJUST

BUTTON LATCH

3.1 Using two **10MM Wrenches**, loosen the **Ball Stud** and adjust as needed. Tighten **Jam Nuts** and verify adjustment by closing the door. Door should click into place easily, release smoothly, and achieve seal compression.

Moving the **Ball Stud** inward will increase seal compression, moving the **Ball Stud** outward will decrease seal compression. Verify seal is at least 50% compressed in the area near the **Ball Stud**.

NOTE - *Do not force the latch closed. If compression is too tight, damage to the latch could occur.*



FIG 5



FIG 6

GET OUT AND EXPLORE!

+ LEAVE US A REVIEW

Happy with your new FVC product? We would love to hear (and see) from you! Head to the product page and click "Leave Review." Add a short review and upload a few photos to be showcased on the product page.

+ SHARE YOUR PICS

We love seeing how our customers use their FVC products and following along with your adventures. Tag us in your photos with: @flatlinevanco or send them to us via email. We love posting customer pictures in our feed!

+ NEED ANY HELP?

If you are having any issues with your product, please reach out, and we will make it right. FVC is a company of van and outdoor enthusiasts that design and use our own products, so we want you to be as stoked on your new parts as we are!



@FLATLINEVANCO