



INSTALLATION GUIDE

SKI STORAGE LOCKER

UN1108B



TOOLS REQUIRED (NOT INCLUDED)

- | | |
|--------------------|----------------|
| + RATCHET | + 9/16" WRENCH |
| + MEASURING TAPE | + 3/8" SOCKET |
| + MARKER | + 10MM WRENCH |
| + 9/16" SOCKET | + 13MM WRENCH |
| + 5MM ALLEN WRENCH | |

INSTALL INFO

TIME TO INSTALL THIS PRODUCT: 1 HOUR

Additional help is suggested for a few of the install steps.
Compatible with all FVC Rear Door Platforms.

BEFORE YOU START

Please inspect the product and packaging upon delivery to ensure there are no issues and that all parts and hardware are accounted for.

Contact us ASAP if anything is missing at:

support@flatlinevanco.com

BEFORE YOU START

All Flatline Van Co products must be properly assembled and secured before attaching to your vehicle. Improper attachment could result in an automobile accident, and could cause serious bodily injury or death to you or to others involved. You are responsible for assembling and securing Flatline Van Co products to your vehicle, checking the mounting points and attachments prior to use, and regularly inspecting the products for wear and or damage. We always recommend you use a professional to install any aftermarket accessories to your vehicle. If you have no mechanical experience and are not thoroughly familiar with the installation procedures, you must have the product installed by a professional installer or other qualified persons. The responsibility is yours and must be taken seriously for everyone's safety.



PACKAGE CONTENTS

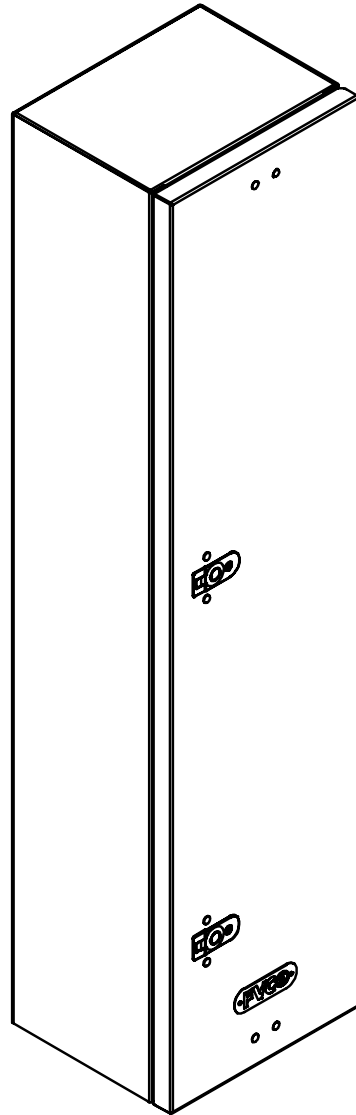

SKI STORAGE LOCKER

QTY: 1

HARDWARE

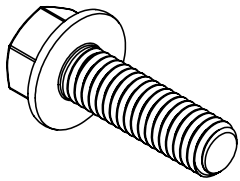

3/8-16 X 1.25 FLANGED HEX
HEAD SCREW

QTY: 6

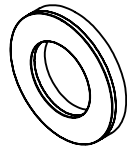

3/8 BONDED
SEALING WASHER

QTY: 6

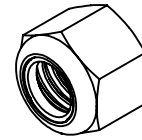

3/8-16 NYLON INSERT
LOCKNUT

QTY: 6



3/8 SCREW FLAT WASHER

QTY: 6

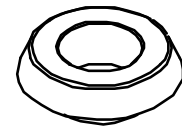

DRAIN PLUG

QTY: 2

INSTALL

STEP | 01 LAYOUT & INSTALL PREP

The Ski Storage Box is designed to be compatible with FVC Rear Door Platforms and B2 Adapter Brackets, but can be modified for installation with other rear door accessory systems.

The box comes pre-assembled from the factory and ready to bolt on. Find the hardware pack inside and familiarize yourself with the contents.

1.1 Dry fit the box to your mounting surface and determine the desired height of install. If you'd rather measure, see **FIG 1** for distances between the mounting points.

1.2 If you are using a product other than the FVC Rear Door Platform, mark the back of the box to match your available mounting points and drill out (4) 3/8" holes accordingly. Plug the factory holes with provided hardware.

PRO-TIP: A table or stand of an appropriate height can be very helpful during this install.

PRO-TIP: Masking tape can also be used to mark desired install height.

NOTE - Modifying your Ski Storage Box for mounting to products other than FVC Rear Door Platforms is done **at your own risk**. If you don't feel comfortable installing this on your own, see our **Find a Builder or Upfitter** page to locate an approved installer near you.

NOTE - Depending on your choice of mounting location for your **Ski Storage Box**, it may interfere with rear sensors/cameras.

TOOLS REQUIRED FOR THIS STEP: + MEASURING TAPE
+ MARKER

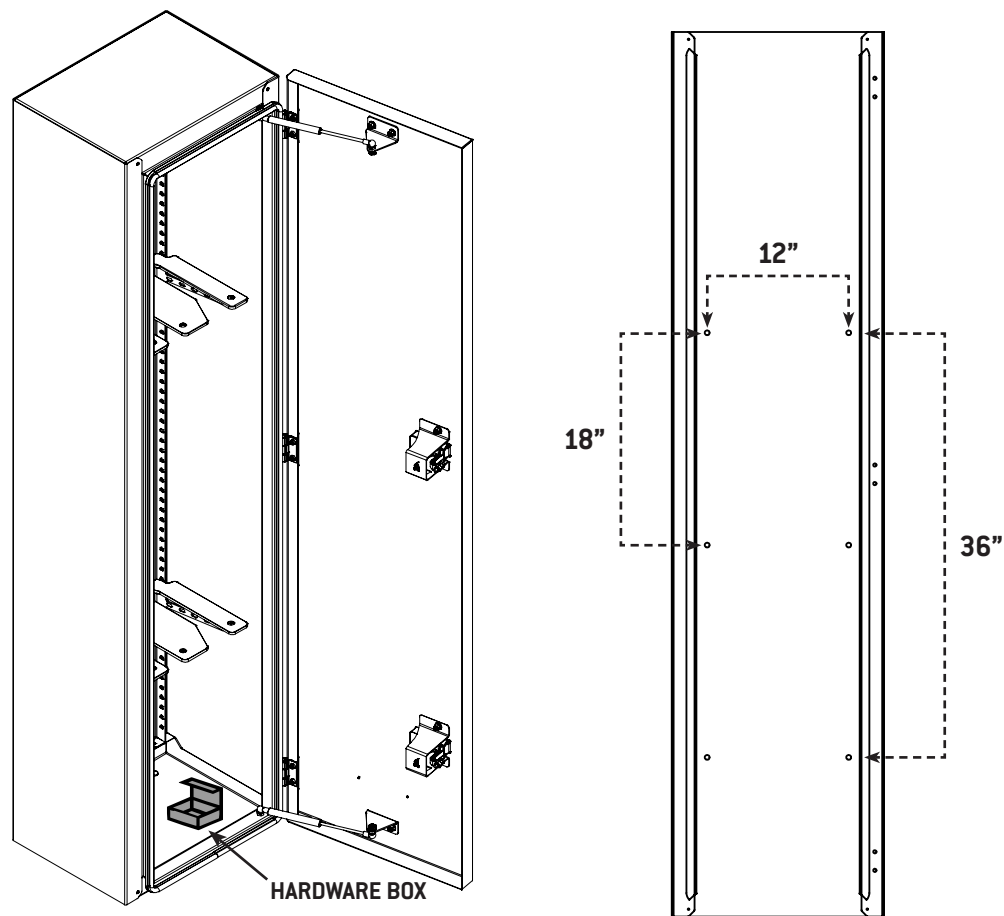

FIG 1

STEP | 02 BOX TO PLATFORM INSTALL

- 2.1 Open the front door of the box to access the mounting holes.
- 2.2 Insert (1ea) **3/8-16 x 1.25" Flanged Hex Head Screws** and **3/8" Sealing Washers** to the upper mounting holes.
- 2.3 With help, lift and align top holes with hardware to the desired height of horizontal 3/8" sized slots of the **Rear Door Platform**.
- 2.4 Reaching around the platform, attach (1ea) **3/8" Flat Washers** to the bolt and loosely thread on (1ea) **3/8" Nylon Lock Nuts** to hold the box in place.
- 2.5 Insert (1ea) **3/8-16 x 1.25" Flanged Hex Head Screws** and **3/8" Sealing Washers** to the middle and lower mounting holes.
- 2.6 Reaching around the platform, attach (1ea) **3/8" Flat Washers** to the bolt and loosely thread on (1ea) **3/8" Nylon Lock Nuts** to hold the box in place.
- 2.7 Verify positioning and tighten down hardware to **20 ft-lbs**
- 2.8 Affix **Sealing Plugs** to drain holes in the bottom of the box tray.

TOOLS REQUIRED FOR THIS STEP: + RATCHET
+ 9/16" SOCKET
+ 9/16" WRENCH

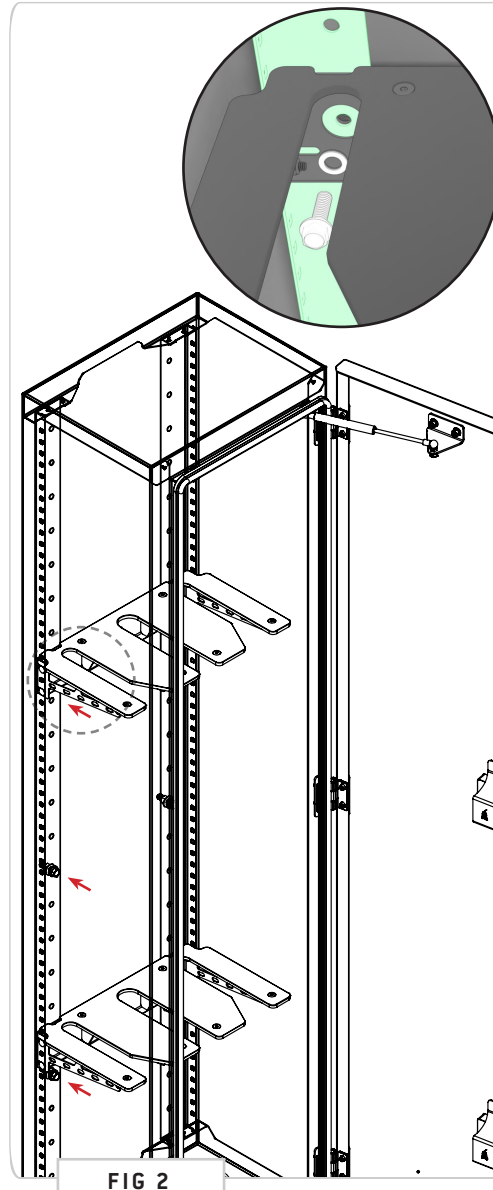

FIG 2

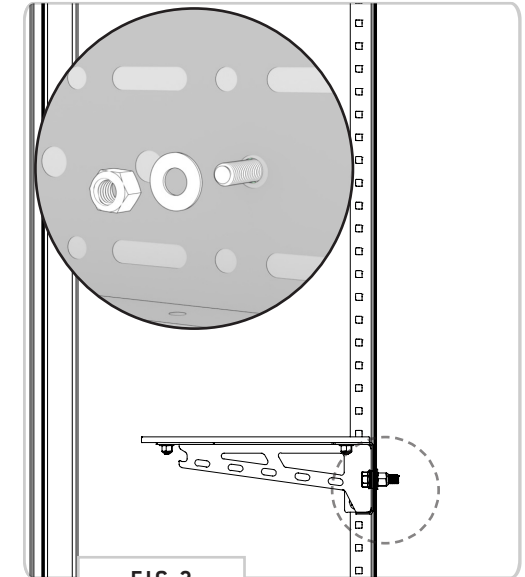

FIG 3

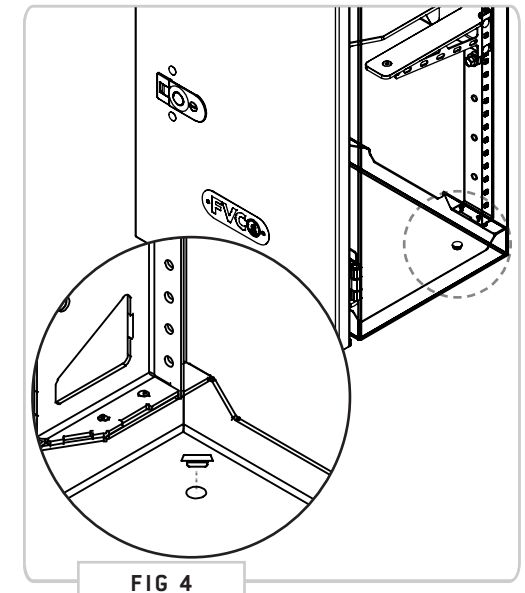

FIG 4

STEP | 03 DOOR ADJUSTMENTS

[AS NEEDED]

DOOR HINGES

3.5 The adjustable torque hinges can be adjusted using a **5MM Allen Wrench**. Tighten the **Hinge Pivot Bolt** to increase torque, loosen **Hinge Pivot Bolt** to decrease torque.

NOTE - We recommend increasing the torque on the lower door hinge. The adjustment helps minimize the door from slamming during opening if accidentally dropped. Tighten hinges equally and test opening to achieve desired feel.

NOTE - We also recommend verifying the top door hinges are only lightly tightened to ensure smooth operation.

COMPRESSION LATCHES

3.2 Using a **10MM Wrench**, loosen the **Jam Nut (FIG 8)** to adjust the **Compression Bolt** and retighten the nut when adjustment is complete.

Screw the bolt out to increase seal compression and screw the bolt in to decrease seal compression.

3.3 With both doors closed, test compression and latch function. When adjusted properly, you should be able to feel the latch compress lightly against the seal for a secure hold. Verify the locking mechanism is working properly and that the release button operates smoothly.

TOOLS REQUIRED FOR THIS STEP: + 13MM WRENCH
+ 10MM WRENCH

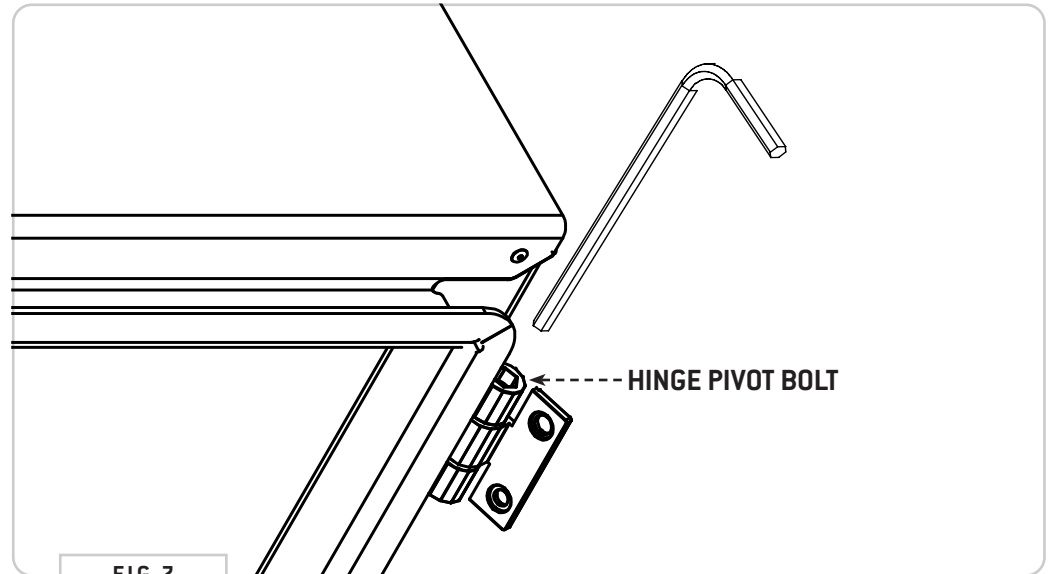

FIG 7

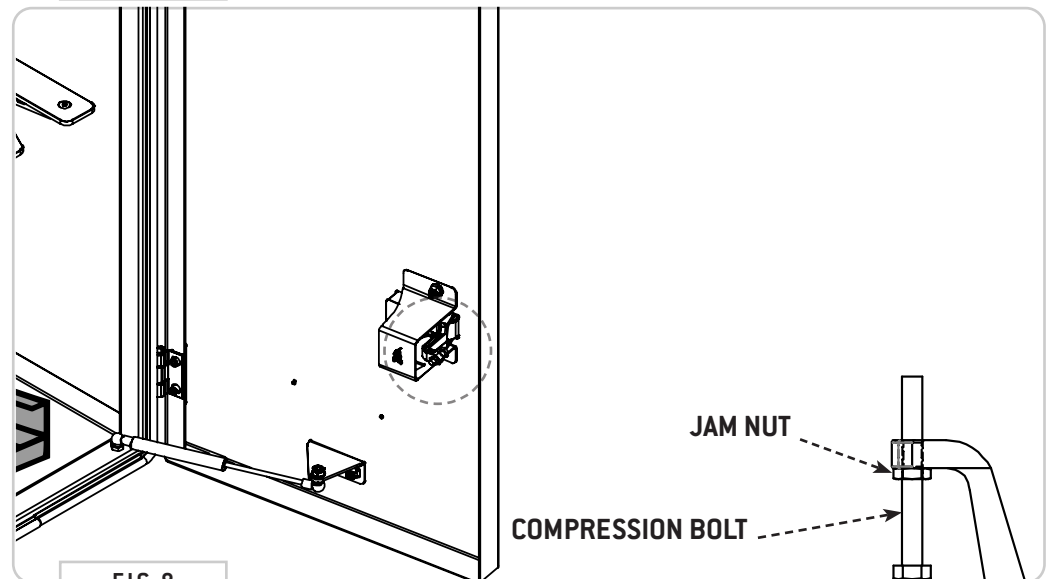

FIG 8

TOOLS REQUIRED FOR THIS STEP: + 10MM WRENCH
+ 5MM ALLEN WRENCH

STEP | 04 SKI/BOARD HOLDER ADJUST

[OPTIONAL]

4.1 Use a 3/8" Socket to remove factory-mounted Ski/Board Holder hardware.

4.2 Adjust to desired height. The Holder is adjustable in 1" increments.

4.3 Set in place using middle holding slots and two 1/4-20 Hex Bolts.

4.4 Tighten shelf using topmost hole and 1/4-20 Hex Bolt.

4.5 Replace hardware for bottom-most mounting points with hardware from the middle holding slots and tighten down.

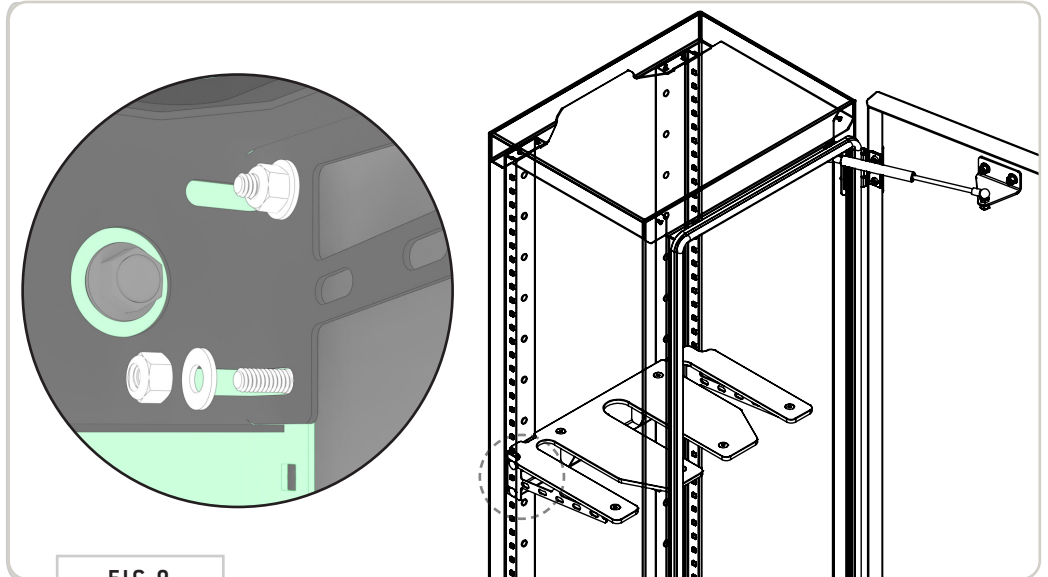

FIG 9

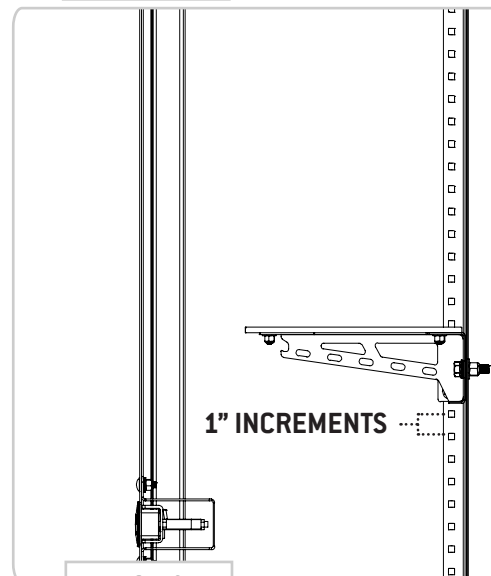

FIG 10

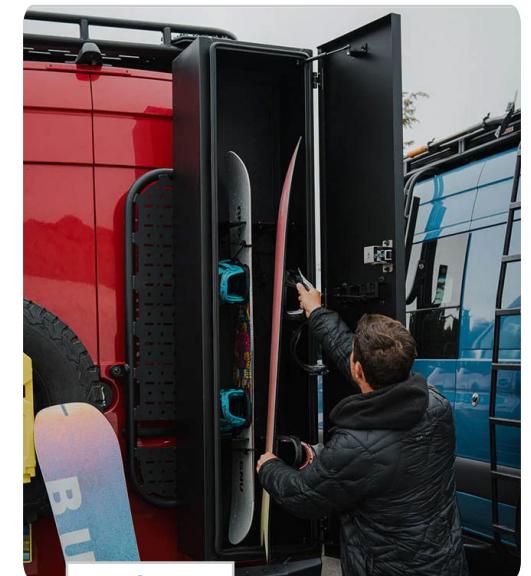

FIG 11

GET OUT AND EXPLORE!

+ LEAVE US A REVIEW

Happy with your new FVC product? We would love to hear (and see) from you! Head to the product page and click "Leave Review." Add a short review and upload a few photos to be showcased on the product page.

+ SHARE YOUR PICS

We love seeing how our customers use their FVC products and following along with your adventures. Tag us in your photos with: @flatlinevanco or send them to us via email. We love posting customer pictures in our feed!

+ NEED ANY HELP?

If you are having any issues with your product, please reach out, and we will make it right. FVC is a company of van and outdoor enthusiasts that design and use our own products, so we want you to be as stoked on your new parts as we are!



@FLATLINEVANCO