



INSTALLATION GUIDE

TRANSIT BED BRACKETS - 148" HIGH ROOF TR0305B



TOOLS REQUIRED (NOT INCLUDED)

- + POWER DRILL
- + POP RIVET TOOL
- + TAPE MEASURE
- + MARKER
- + CLAMP OR SELF DRILLING SCREWS
- + RUST PREVENTATIVE PAINT

INSTALL INFO

TIME TO INSTALL THIS PRODUCT: 2 HOURS

Additional help is suggested for a few of the install steps.

BEFORE YOU START

Please inspect the product and packaging upon delivery to ensure there are no issues and that all parts and hardware are accounted for.

Contact us ASAP if anything is missing at:
support@flatlinevanco.com

BEFORE YOU START

All Flatline Van Co products must be properly assembled and secured before attaching to your vehicle. Improper attachment could result in an automobile accident, and could cause serious bodily injury or death to you or to others involved. You are responsible for assembling and securing Flatline Van Co products to your vehicle, checking the mounting points and attachments prior to use, and regularly inspecting the products for wear and or damage. We always recommend you use a professional to install any aftermarket accessories to your vehicle. If you have no mechanical experience and are not thoroughly familiar with the installation procedures, you must have the product installed by a professional installer or other qualified persons. The responsibility is yours and must be taken seriously for everyone's safety.



PACKAGE CONTENTS



**DRIVER FRONT
BRACKET**

QTY: 1

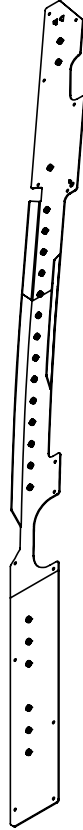

**PASSENGER FRONT
BRACKET**

QTY: 1

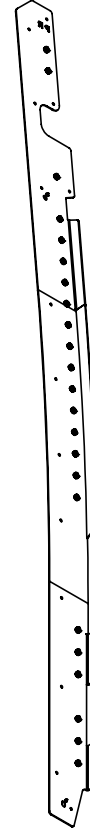

**PASSENGER REAR
BRACKET**

QTY: 1

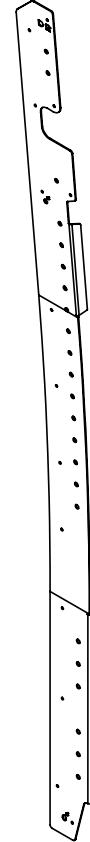

**DRIVER REAR
BRACKET**

QTY: 1

HARDWARE

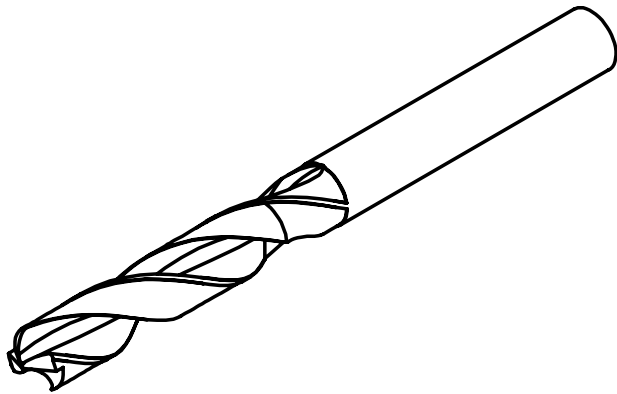

0.196 SHORT STEEL DRILL BIT

QTY: 2

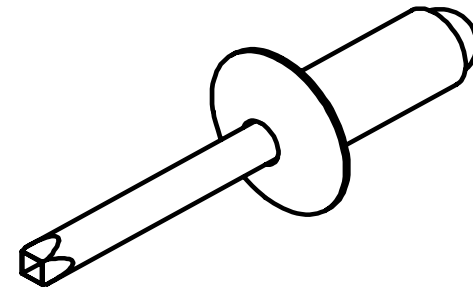

3/16 X .125-.250 THK DOMED HEAD BLIND
ALUMINUM RIVET

QTY: 60

INSTALL

STEP | 01 LAYOUT AND INSTALL PREP

1.1 Driver Side Alignment Locations: See FIG 1 for alignment hole locations for **Driver Side Bracket** installation.

1.2 Passenger Side Alignment Locations: See FIG 2 for alignment hole locations for **Passenger Side Bracket** installation.

NOTE - This install requires the removal of any interior panels that span the locations shown in FIG 1 and 2.

NOTE - The Bed Brackets may not be compatible with certain trim ring configurations.

TOOLS REQUIRED FOR THIS STEP:

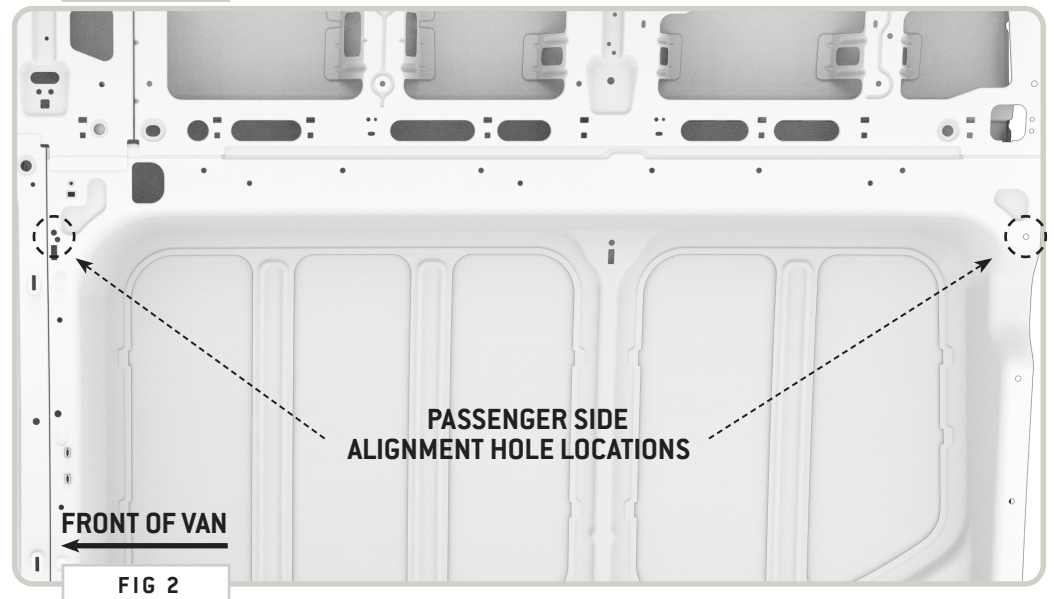
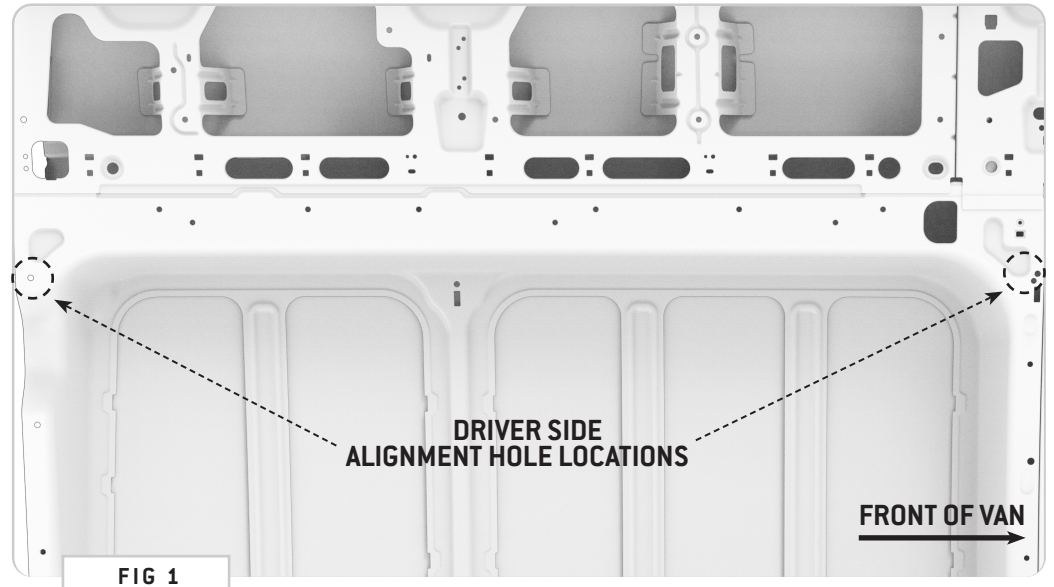

INSTALL

STEP | 01 LAYOUT AND INSTALL PREP

1.3 Front Bracket Info: See the images to the right for information regarding which holes in your **Bed Brackets** are used for installing to the van, attaching your **Bed System**, or are supplemental.

TOOLS REQUIRED FOR THIS STEP:

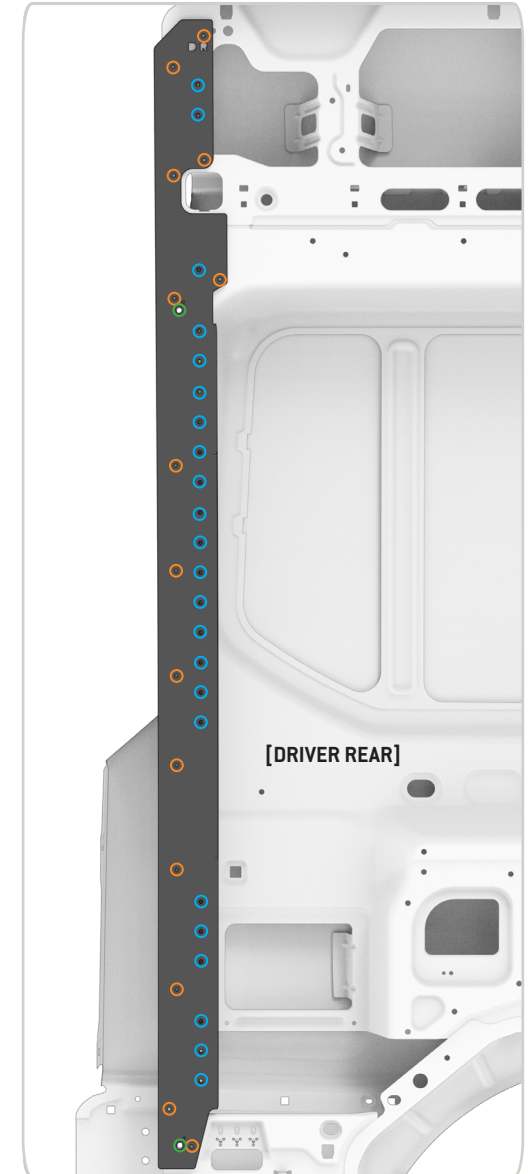
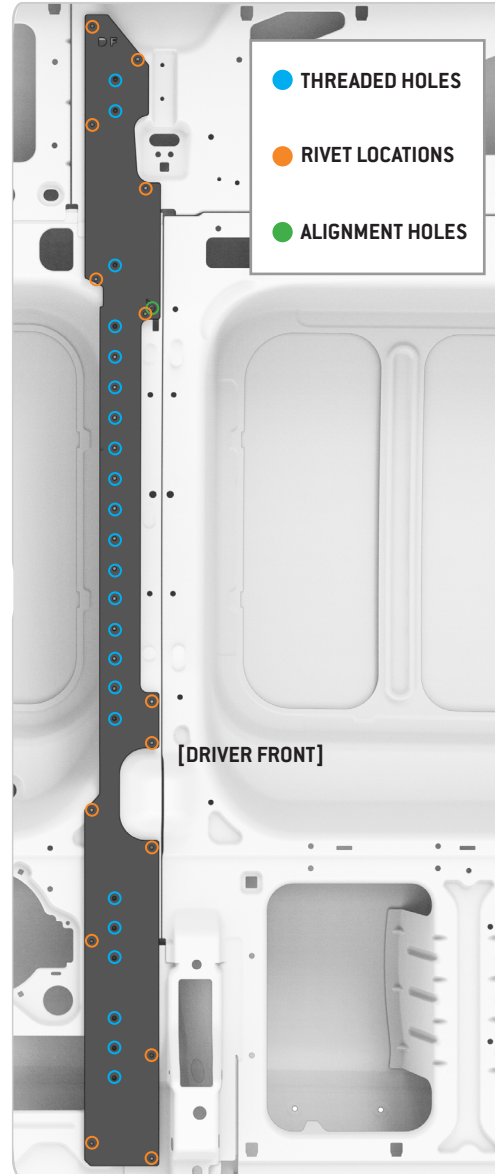

STEP | 02 DRIVER SIDE BRACKETS

2.1 Align Driver Side Front Bracket: Align the **Driver Side Front Bracket** to the **Alignment Point** as shown in **FIG 3**. There should also be a **Body Seam** that you can use as a visual guide.

2.2 Set Driver Side Front Bracket Into Place: Set the **Driver Side Front Bracket** into place with clamps or by driving two sheet metal screws through two **Rivet Holes** to hold it in place.

2.3 Align Driver Side Rear Bracket: Align the **Driver Side Rear Bracket** to the **Alignment Point** as shown in **FIG 4**.

2.4 Set Driver Side Rear Bracket Into Place: Set the **Driver Side Rear Bracket** into place with clamps or by driving two sheet metal screws through two **Rivet Holes** to hold it in place.

TOOLS REQUIRED FOR THIS STEP:

- + POWER DRILL
- + QUICK CLAMP
- + SELF TAPPING SCREW

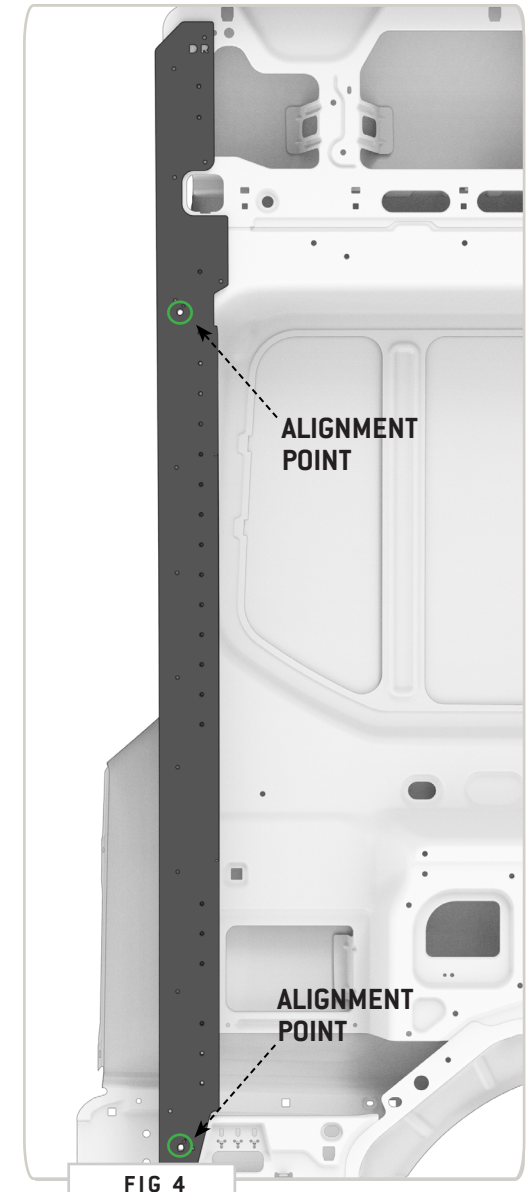
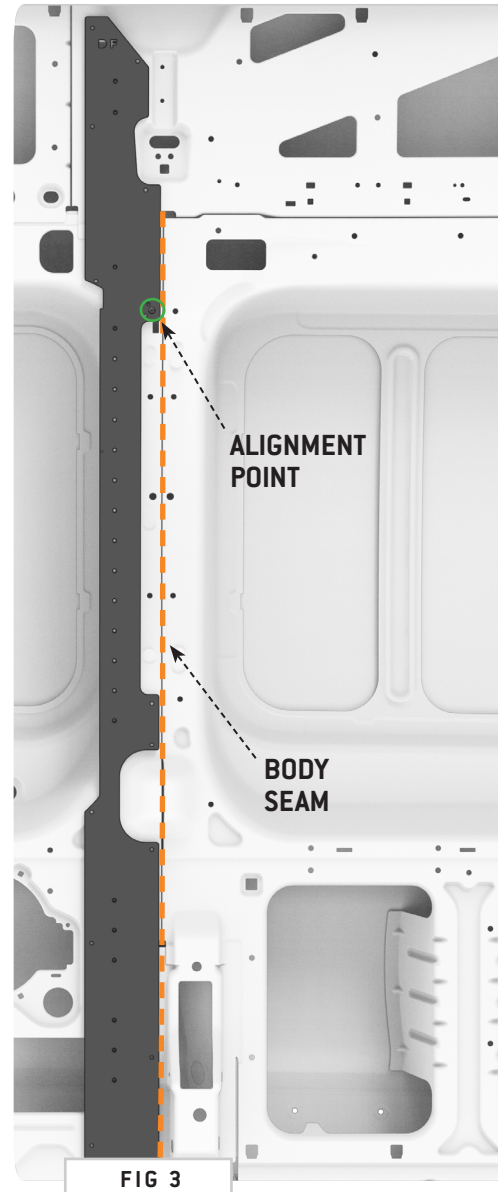

STEP | 02 DRIVER SIDE BRACKETS

2.5 Mark Holes to Clear Threaded Pem Nuts: Next, you need to mark the clearance holes needing to be drilled behind the threaded holes. Using a narrow tipped pen (like an Ultra-Fine Sharpie) mark through the threaded holes.

2.6 Drill Out Clearance Holes: Once you've marked every hole, remove your wall brackets and drill the clearance holes. Start with the **3/16"** Drill bit, and then either use a **Step Bit** or a **9/16"** Drill bit to finish them. Once finished drilling, put your wall brackets up one more time using the self tapping screws.

TOOLS REQUIRED FOR THIS STEP:

- + POWER DRILL
- + QUICK CLAMP
- + SELF TAPPING SCREW



STEP | 03 PASSENGER SIDE BRACKETS

3.1 Align Passenger Side Front Bracket: Align the **Passenger Side Front Bracket** to the **Alignment Point** as shown in FIG 7. There should also be a **Body Seam** that you can use as a visual guide.

3.2 Set Passenger Side Front Bracket Into Place: Set the **Passenger Side Front Bracket** into place with clamps or by driving a sheet metal screw through one of the **Rivet Nut** slots to hold it in place.

3.3 Align Passenger Side Rear Bracket: Align the **Passenger Side Rear Bracket** to the **Alignment Point** as shown in FIG 8.

3.4 Set Passenger Side Rear Bracket Into Place: Set the **Passenger Side Rear Bracket** into place with clamps or by driving two sheet metal screws through two **Rivet Slots** to hold it in place.

TOOLS REQUIRED FOR THIS STEP: + POWER DRILL
+ QUICK CLAMP
+ SELF TAPPING SCREW

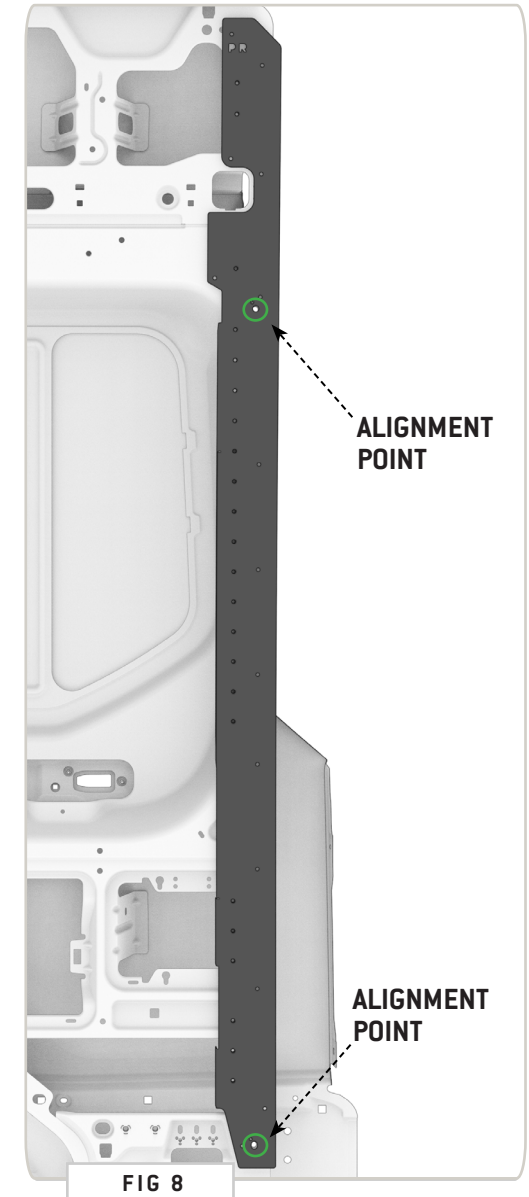
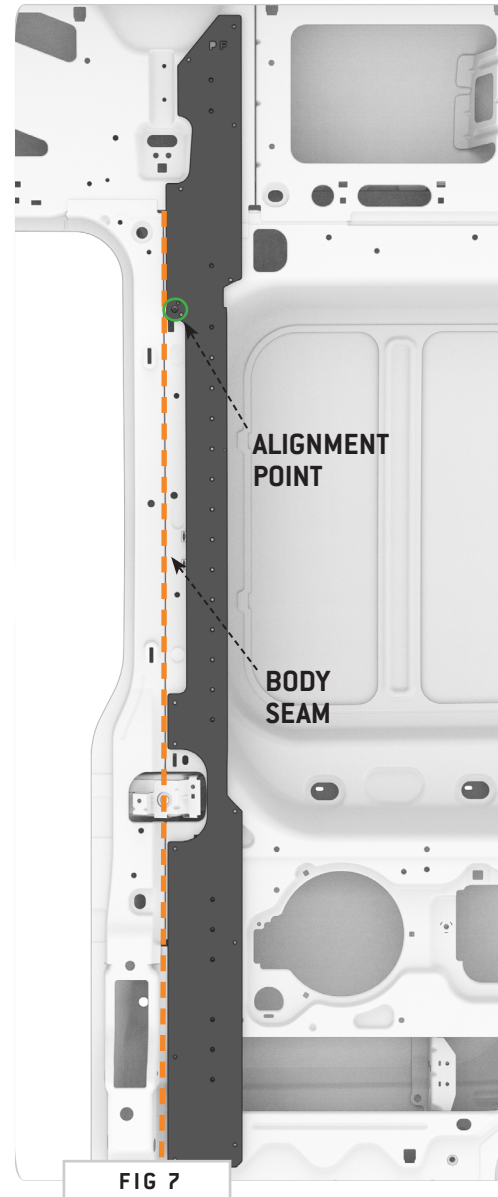

- TOOLS REQUIRED FOR THIS STEP:**
- + POWER DRILL
 - + QUICK CLAMP
 - + SELF TAPPING SCREW

STEP | 03 PASSENGER SIDE BRACKETS

3.5 Mark Holes to Clear Threaded Pem Nuts: Notice the locations highlighted in FIG 9+10. Mark through these threaded holes to drill out for clearance.

3.6 Drill Out Clearance Holes: Remove the clamps or screws holding your **Brackets** in place and drill out clearance holes using a 23/64" or similar sized Drill Bit.



FIG 9



FIG 10

STEP | 04 SECURING DRIVER SIDE

4.1 Measure Bracket Spacing: Once you have the clearance holes drilled, you'll need to resecure the **Bed Brackets** and confirm that the distance between rail mounting points are square at 63.5" thread insert to thread insert (**FIG 11**).

PRO-TIP: *If you mark the sheet metal as you measure, this can help in keeping your place between adjustments.*

4.2 Securing the Driver Side Front Bracket: Double-check your measurements against your marks and proceed to secure the **Driver Side Front Bracket** by drilling through all of the **Rivet Holes** with a **3/16" or similar sized Drill Bit (FIG 12)** and painting with a rust preventative paint.

4.3 Install Rivets: After the paint has dried, install the **Rivets (FIG 13)**.

4.4 Finishing the Driver's Side Install: Double-check your measurements one last time before installing the remaining Rivets on the **Driver Side Rear Bracket**.

NOTE - *Be sure to remove the self-tapping screws (if applicable) and replace them with **Pop Rivets**.*

TOOLS REQUIRED FOR THIS STEP:

- + TAPE MEASURE
- + MARKER
- + POWER DRILL
- + POP RIVET TOOL
- + RUST PREVENTATIVE PAINT



FIG 11

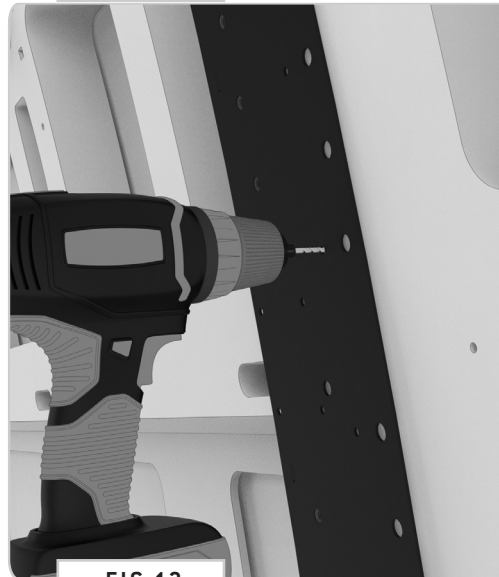

FIG 12

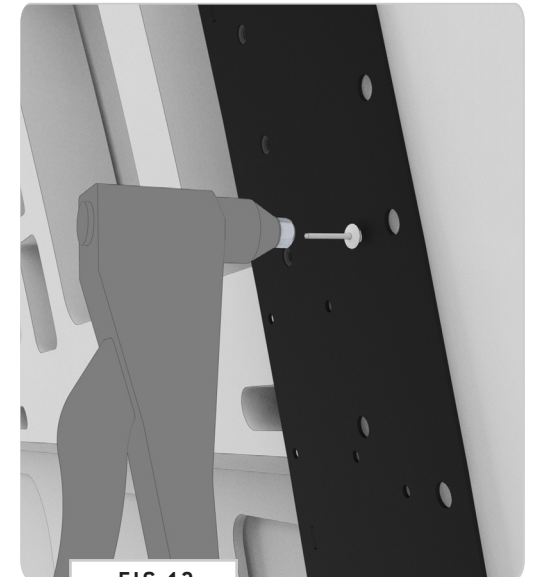

FIG 13

STEP | 05 SECURING PASSENGER SIDE

5.1 Measure Bracket Spacing: Once you have the clearance holes drilled, you'll need to resecure the **Bed Brackets** and confirm that the distance between rail mounting points are square at 63.5" thread insert to thread insert (**FIG 14**).

PRO-TIP: *If you mark the sheet metal as you measure, this can help in keeping your place between adjustments.*

5.2 Securing the Passenger Side Rear Bracket: Double-check your measurements against your marks and proceed to secure the **Passenger Side Front Bracket** by drilling through all of the **Rivet Holes** with a **3/16"** or similar sized **Drill Bit** (**FIG 15**) and painting with a rust preventative paint.

5.3 Install Rivets: After the paint has dried, install the **Rivets** (**FIG 16**).

5.4 Finishing the Passenger's Side Install: Double-check your measurements one last time before installing the remaining **Rivets** on the **Passenger Side Rear Bracket**.

NOTE - *Be sure to remove the self-tapping screws (if applicable) and replace them with **Pop Rivets**.*

TOOLS REQUIRED FOR THIS STEP:

- + TAPE MEASURE
- + MARKER
- + POWER DRILL
- + POP RIVET TOOL
- + RUST PREVENTATIVE PAINT

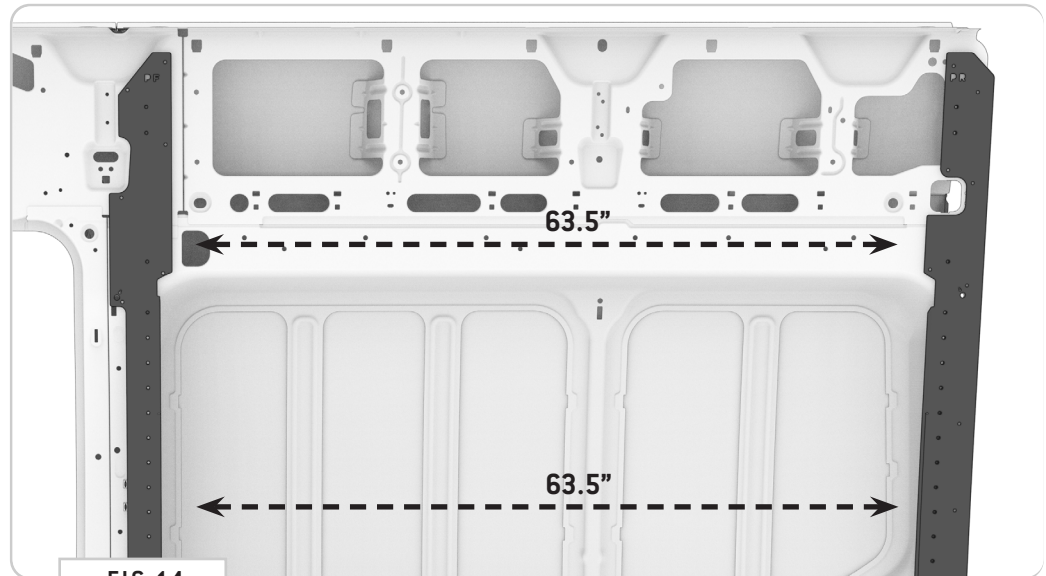

FIG 14

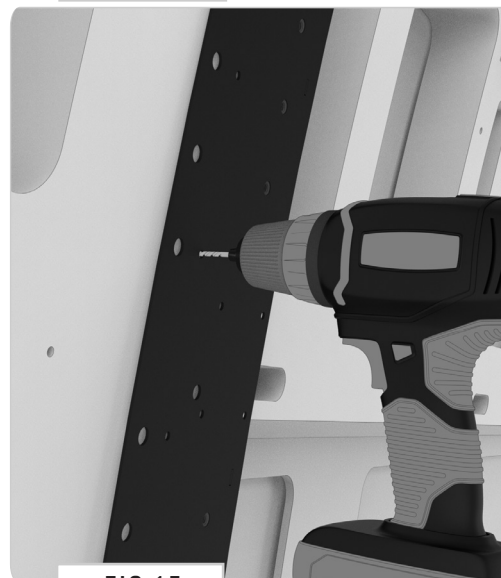

FIG 15

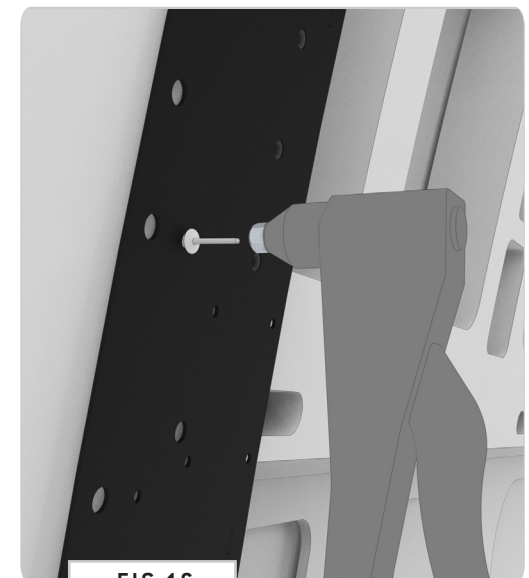

FIG 16

GET OUT AND EXPLORE!

+ LEAVE US A REVIEW

Happy with your new FVC product? We would love to hear (and see) from you! Head to the product page and click "Leave Review." Add a short review and upload a few photos to be showcased on the product page.

+ SHARE YOUR PICS

We love seeing how our customers use their FVC products and following along with your adventures. Tag us in your photos with: @flatlinevanco or send them to us via email. We love posting customer pictures in our feed!

+ NEED ANY HELP?

If you are having any issues with your product, please reach out, and we will make it right. FVC is a company of van and outdoor enthusiasts that design and use our own products, so we want you to be as stoked on your new parts as we are!



@FLATLINEVANCO