



# INSTALLATION GUIDE

## TRANSIT VAN LOW PRO ROOF RACK LIGHT BAR FAIRING (ALL TYPES)

TR0122B + TR0123B

### TOOLS REQUIRED (NOT INCLUDED)

- + 7/16" WRENCH OR SOCKET
- + 5/32" ALLEN WRENCH
- + 3/16" ALLEN WRENCH

### INSTALL INFO

TIME TO INSTALL THIS PRODUCT: 1-2 HOURS

Additional help is suggested for a few of the install steps.

### BEFORE YOU START

Please inspect the product and packaging upon delivery to ensure there are no issues and that all parts and hardware are accounted for.

Contact us ASAP if anything is missing at:  
[support@flatlinevanco.com](mailto:support@flatlinevanco.com)

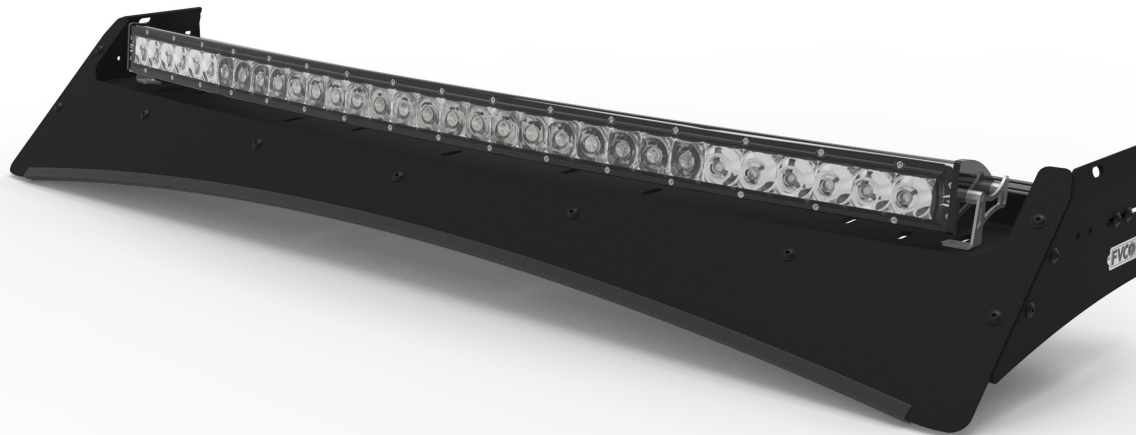

# BEFORE YOU START

All Flatline Van Co products must be properly assembled and secured before attaching to your vehicle. Improper attachment could result in an automobile accident, and could cause serious bodily injury or death to you or to others involved. You are responsible for assembling and securing Flatline Van Co products to your vehicle, checking the mounting points and attachments prior to use, and regularly inspecting the products for wear and or damage. We always recommend you use a professional to install any aftermarket accessories to your vehicle. If you have no mechanical experience and are not thoroughly familiar with the installation procedures, you must have the product installed by a professional installer or other qualified persons. The responsibility is yours and must be taken seriously for everyone's safety.



# PACKAGE CONTENTS

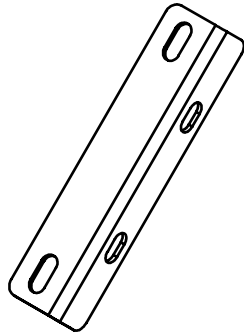

FAIRING SIDE BRACKET

QTY: 2

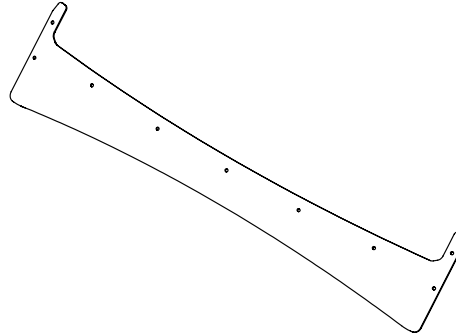

FRONT FAIRING

QTY: 1

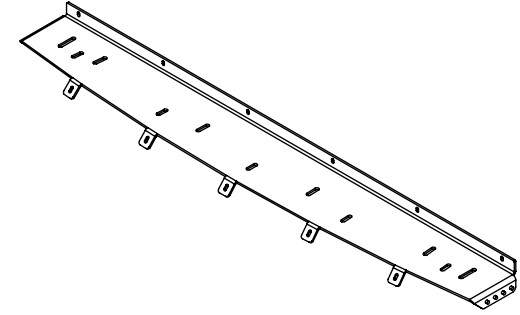

LIGHT BAR TRAY

QTY: 1

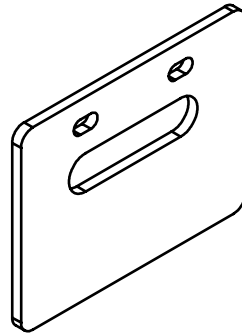

AWNING SPACER PLATE

QTY: 3

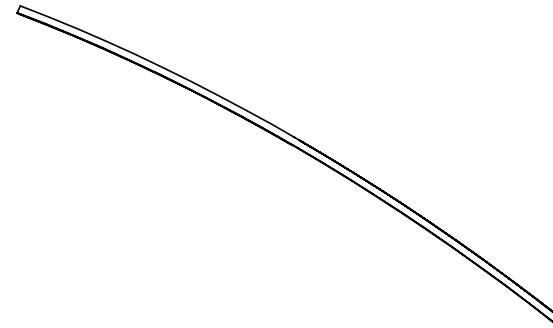

FAIRING GASKET

QTY: 1

TOOLS REQUIRED FOR THIS STEP: + 5/32" ALLEN WRENCH

## STEP | 01 FAIRING ASSEMBLY

**1.1 Crossbar Fairing Bracket:** Stack a **1/4-20" x 0.5 Button Head Screw** and **1/4" Belleville Lock Washer** as shown in **FIG 1** and insert into the six available front holes of the **Fairing Light Bar Tray**. Loosely assemble using a **T-Nut**. You'll only want to screw the **T-Nuts** on a little in order to provide clearance for the next step.

**1.2 Crossbar Install:** Now, slide a **Crossbar** onto the **Crossbar Fairing Bracket**. You'll have to straighten each **T-Nut** as you go to get it to feed into the crossbar correctly (**FIG 2 + 3**).

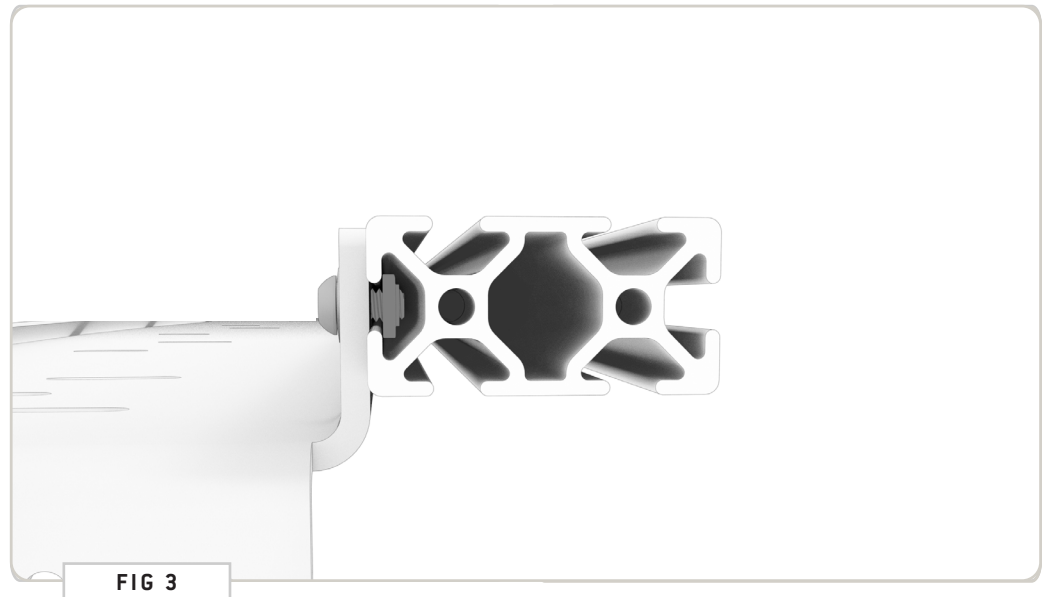
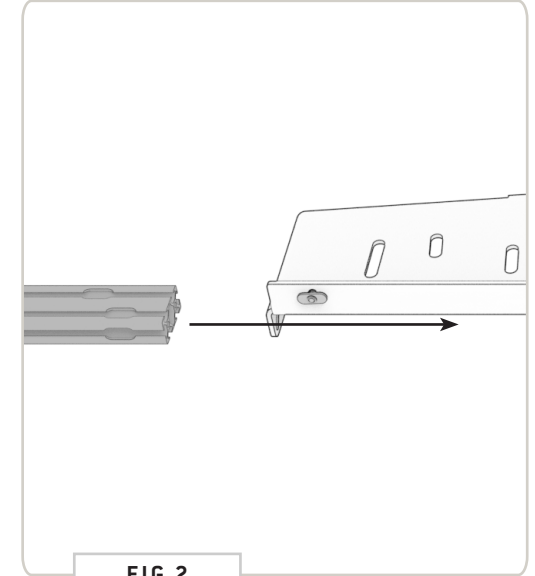
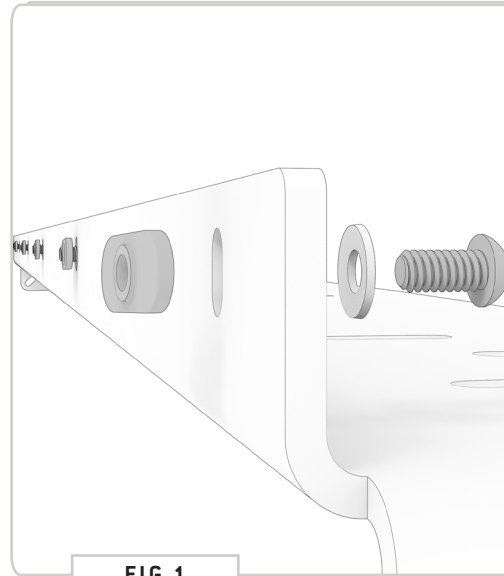

**TOOLS REQUIRED FOR THIS STEP:** + 5/32" ALLEN WRENCH  
+ 7/16" WRENCH OR SOCKET

## STEP | 01 FAIRING ASSEMBLY

**1.3 Attach Front Fairing:** Attach the Front Fairing to the Assembly using 1/4-20 x 0.75 Flanged Button Head Screws, Flat Washers and Nylon Locknuts (FIG 4 + 5).

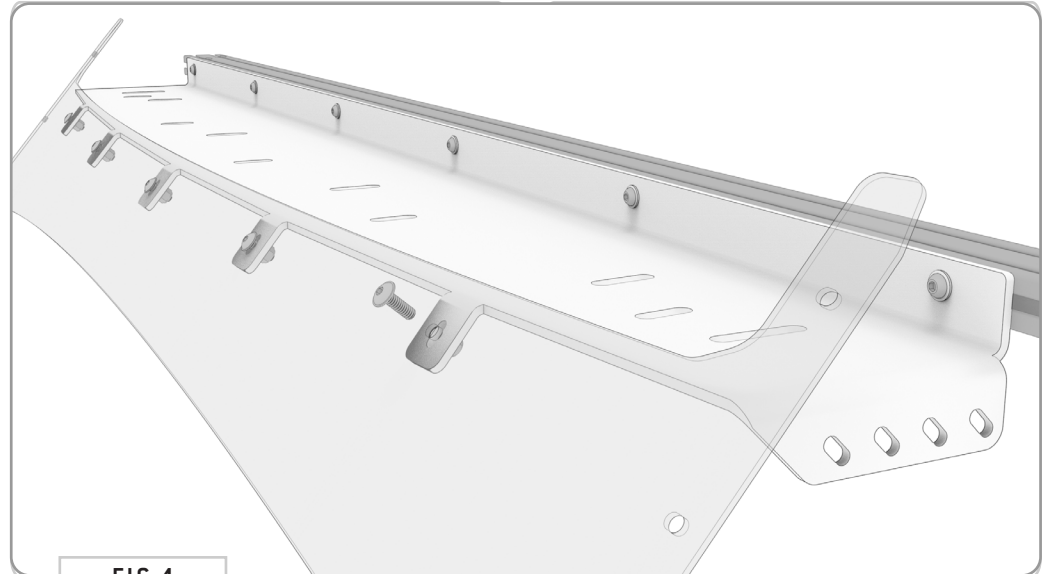

FIG 4

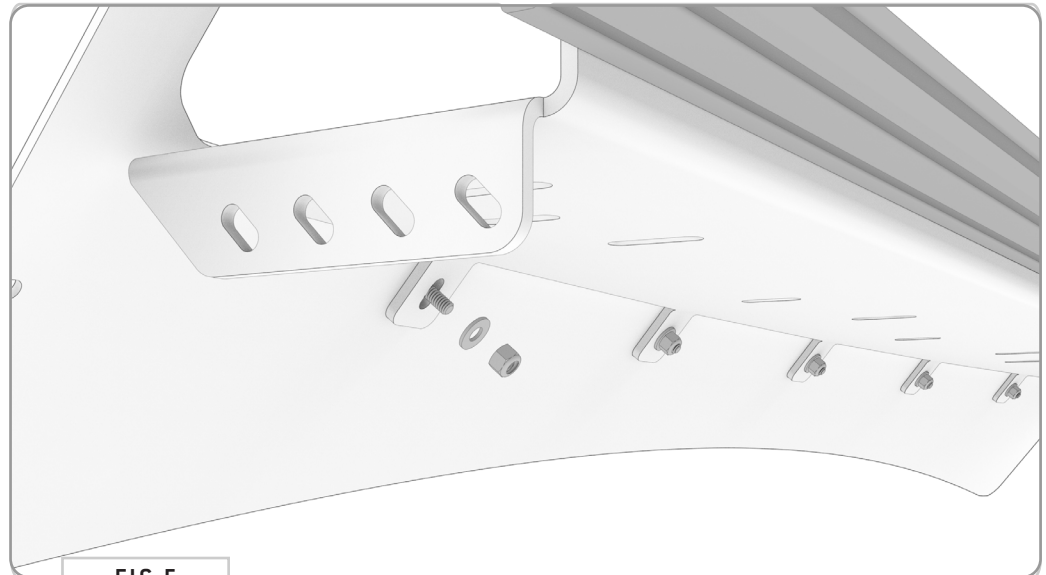

FIG 5

## STEP | 01 FAIRING ASSEMBLY

**1.4 Attach Fairing Side Brackets:** Loosely attach **Fairing Side Brackets** to the **Fairing Assembly** using **1/4"-20 Flanged Head Screws, Flat Washers and Nylock Locknuts**. Note that the flanged face of these Fairing Brackets will face outward as shown in **FIG 19**.

**1.5 Attach Trim Gasket:** Complete the assembly by attaching the **Trim Gasket (FIG 20)**. Make sure that the "bulbed" side of the trim is facing the Crossbar, as that will be the part that sits against the van.

**PRO-TIP:** Gently tap the **Trim Gasket** using a mallet to seat it down tight against the **Fairing**.

**TOOLS REQUIRED FOR THIS STEP:** + 5/32" ALLEN WRENCH  
+ 7/16" WRENCH OR SOCKET

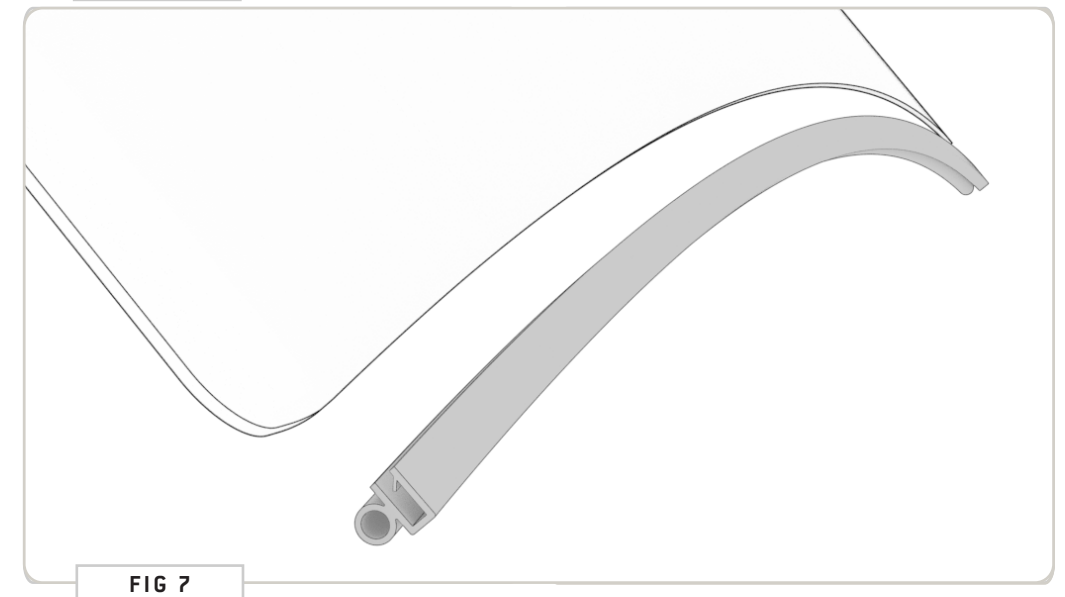
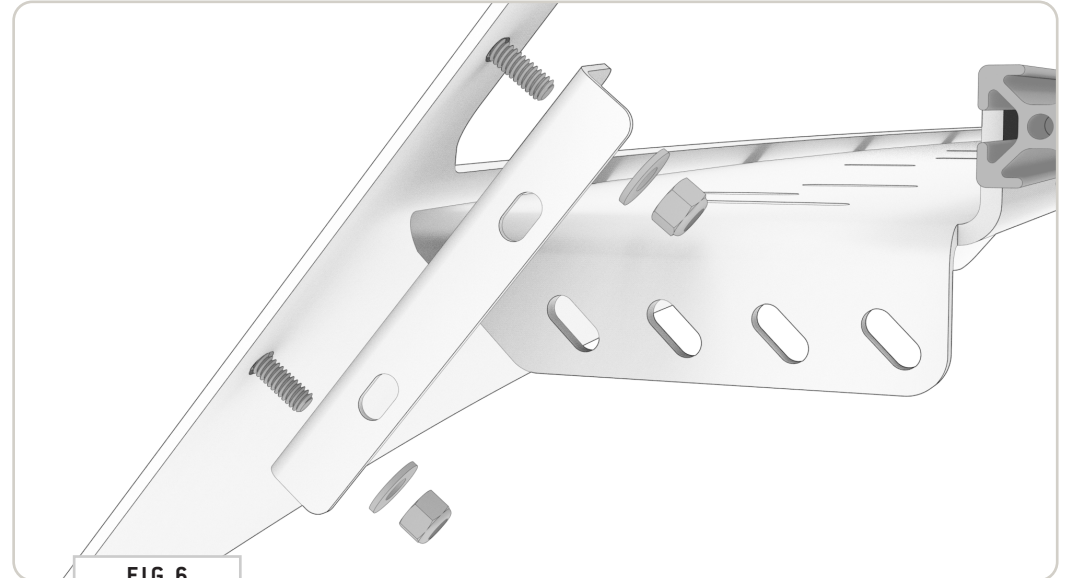

**TOOLS REQUIRED FOR THIS STEP:** + 5/32" ALLEN WRENCH  
+ 7/16" WRENCH OR SOCKET

## STEP | 02 FAIRING INSTALL

**2.1 Install Fairing:** With help, lift the **Fairing Assembly** up to the front of your **Roof Rack** and gently lay it down on a soft surface (**FIG 8**).

**2.2 Tighten Fairing to Brackets:** There is a bit of adjustment built in to the **Fairing Brackets** so that you maintain a tight seal against the van body during install. Proceed to tighten down the fasteners holding the **Fairing** to the **Fairing Brackets** once you've determined an appropriate fit (**FIG 9**).

**2.3 Tighten Fairing to Side Rails:** Tighten down the fasteners holding the **Fairing Assembly** to the **Side Rails** (**FIG 10**).



FIG 8



FIG 9

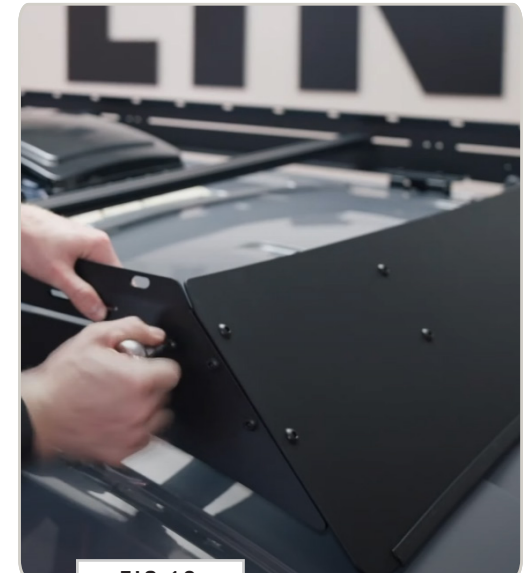

FIG 10

# GET OUT AND EXPLORE!

## + LEAVE US A REVIEW

---

Happy with your new FVC product? We would love to hear (and see) from you! Head to the product page and click "Leave Review." Add a short review and upload a few photos to be showcased on the product page.

## + SHARE YOUR PICS

---

We love seeing how our customers use their FVC products and following along with your adventures. Tag us in your photos with: @flatlinevanco or send them to us via email. We love posting customer pictures in our feed!

## + NEED ANY HELP?

---

If you are having any issues with your product, please reach out, and we will make it right. FVC is a company of van and outdoor enthusiasts that design and use our own products, so we want you to be as stoked on your new parts as we are!



@FLATLINEVANCO