



# INSTALLATION GUIDE

## SPRINTER HEADLINER SHELF AND CURTAIN ROD SP5002B + SP1010B



### TOOLS REQUIRED (NOT INCLUDED)

- |                          |                          |
|--------------------------|--------------------------|
| + T25 TORX               | + POWER DRILL            |
| + T30 TORX               | + MARKER                 |
| + 7/16" WRENCH OR SOCKET | + 7/16" WRENCH OR SOCKET |
| + 5/32" ALLEN WRENCH     | + 9/32" DRILL BIT        |
| + FLATHEAD SCREWDRIVER   |                          |

### INSTALL INFO

TIME TO INSTALL THIS PRODUCT: 1 HOUR

Additional help is suggested for a few of the install steps.  
Compatible with all FVC Rear Door Platforms.

### BEFORE YOU START

Please inspect the product and packaging upon delivery to ensure there are no issues and that all parts and hardware are accounted for.

Contact us ASAP if anything is missing at:  
[support@flatlinevanco.com](mailto:support@flatlinevanco.com)

# BEFORE YOU START

All Flatline Van Co products must be properly assembled and secured before attaching to your vehicle. Improper attachment could result in an automobile accident, and could cause serious bodily injury or death to you or to others involved. You are responsible for assembling and securing Flatline Van Co products to your vehicle, checking the mounting points and attachments prior to use, and regularly inspecting the products for wear and or damage. We always recommend you use a professional to install any aftermarket accessories to your vehicle. If you have no mechanical experience and are not thoroughly familiar with the installation procedures, you must have the product installed by a professional installer or other qualified persons. The responsibility is yours and must be taken seriously for everyone's safety.



# PACKAGE CONTENTS

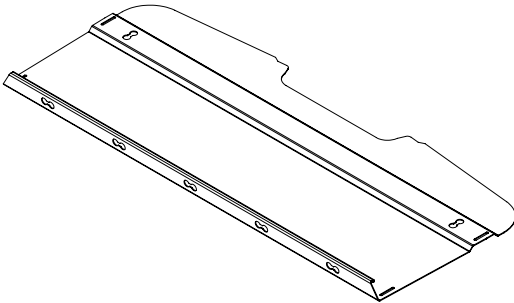

HEADLINER SHELF

QTY: 1

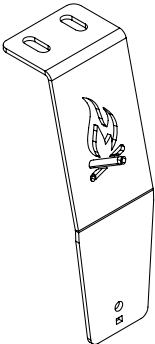

B-PILLAR BRACKET

QTY: 2

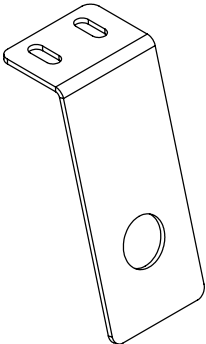

GRAB HANDLE BRACKET

QTY: 2

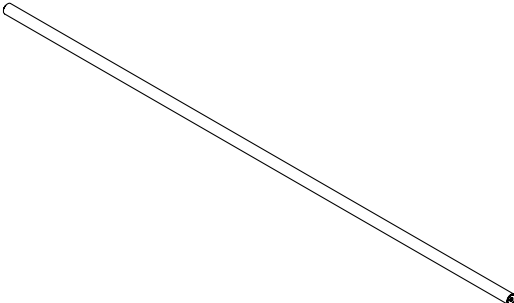

CURTAIN ROD WELDMENT

QTY: 1

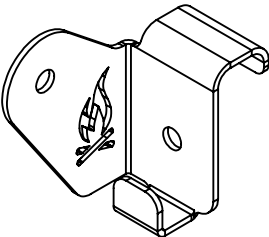

DRIVER SIDE BRACKET

QTY: 1

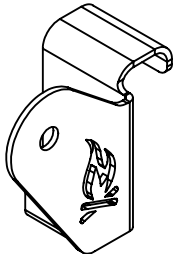

PASSENGER SIDE CURTAIN BRACKET

QTY: 1

# HARDWARE

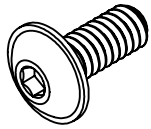

1/4-20 X 0.75 FLANGED  
BUTTON HEAD HEX DRIVE  
SCREW

QTY: 12

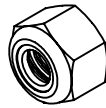

1/4-20 NYLON INSERT  
LOCKNUT

QTY: 10



1/4 SCREW FLAT WASHER

QTY: 10

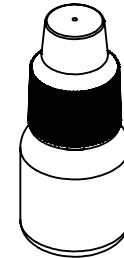

THREADLOCKER

QTY: 1

# INSTALL

TOOLS REQUIRED FOR THIS STEP: + FLATHEAD SCREWDRIVER  
+ T25 TORX

## STEP | 01 REMOVE COAT HOOKS

**1.1 Remove Coat Hooks on B-Pillar:** Use a Flathead Screwdriver to gently pry off the Coat Hook Covers (FIG 2) on the B-Pillar before using a T25 Torx to remove the screws holding the Coat Hook Brackets in place (FIG 4).

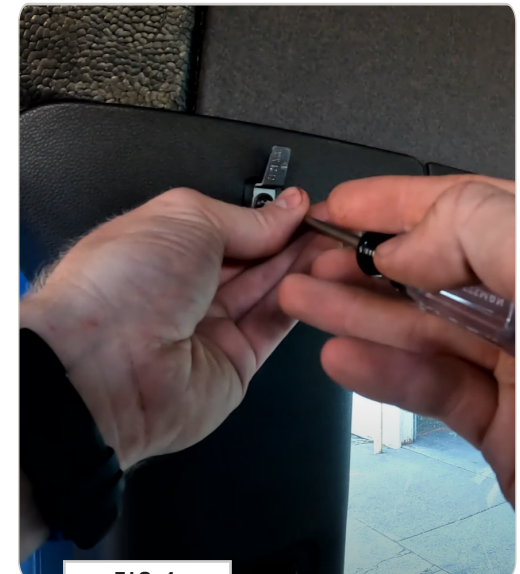
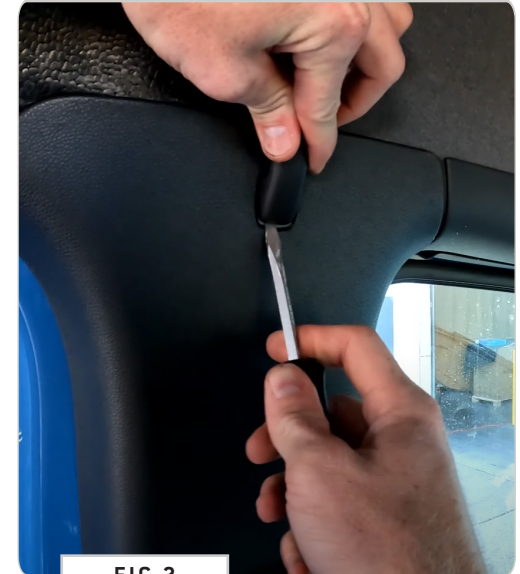

TOOLS REQUIRED FOR THIS STEP: + T25 TORX

## STEP | 02 INSTALL B-PILLAR BRACKETS

**2.1 Position Bracket Behind Plastic:** Place the **B-Pillar Bracket** behind the **Plastic Trim** of the **B-Pillar** (FIG 5) and align the holes of the bracket with that of the trim (FIG 6).

**2.2 Secure Bracket Behind Plastic:** Secure the **B-Pillar Bracket** using the factory hardware and **Coat Hook Bracket** removed in the previous steps. Cap with the **Coat Hook Cover** (FIG 8).

Repeat this process for both sides of the van.



FIG 5

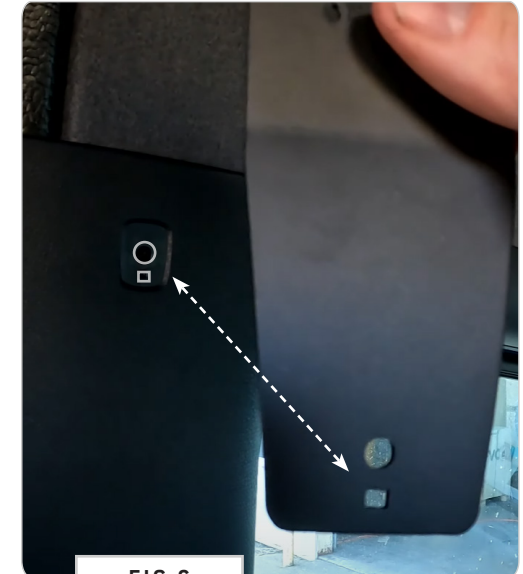

FIG 6

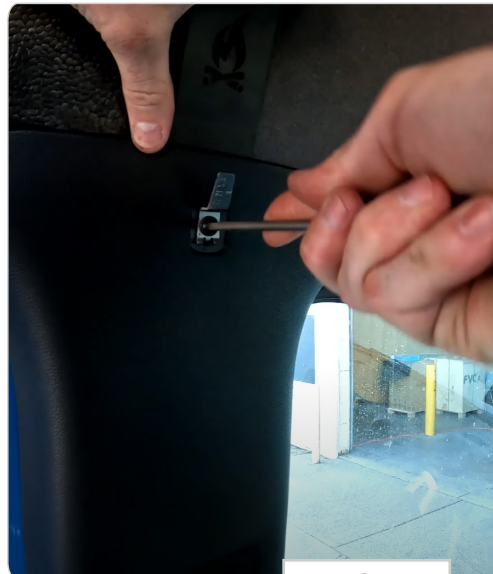

FIG 7



FIG 8

TOOLS REQUIRED FOR THIS STEP: + T30 TORX

## STEP | 03 INSTALL GRAB BRACKETS

**3.1 Loosen Factory Grab Handle From Van Wall:** Use a T30 Torx to remove the screws holding the factory **Grab Handle** (FIG 9+10) in place and loosen from van wall.

**NOTE -** *There is a structural metal insert inside the handle that can make it difficult to pull away from the wall, so you may need to pry it out a bit to loosen it up enough for bracket install.*

**3.2 Install Bracket Behind Factory Handle:** Position the **Grab Bracket** behind the factory **Grab Handle** (FIG 11), reusing the handle's screws to loosely hold the **Grab Bracket** in place while you position the **Headliner Shelf** for adjustment (FIG 12).

Repeat this process for the other side of the van.



FIG 9

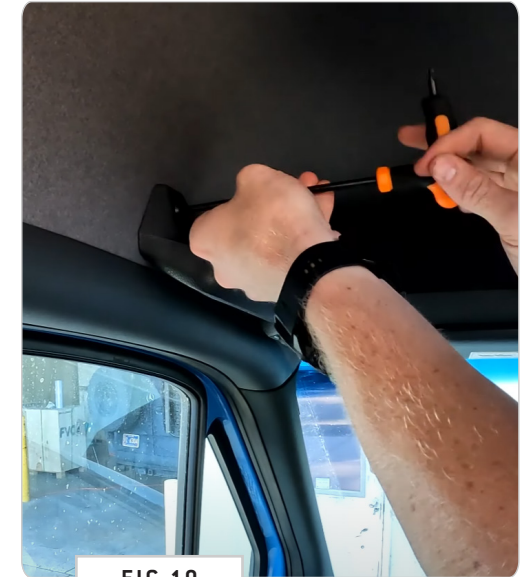

FIG 10



FIG 11

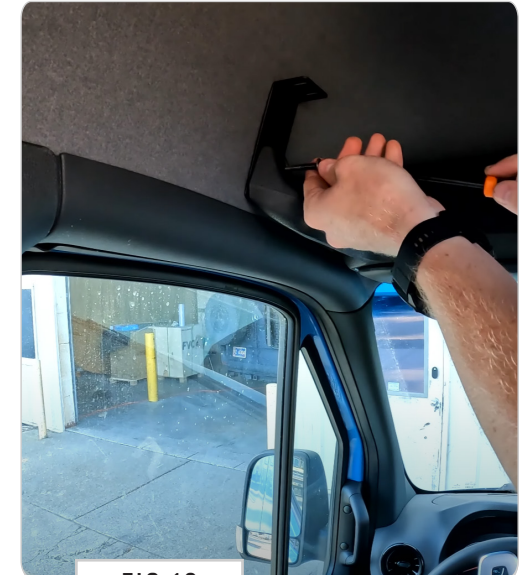

FIG 12

## STEP | 04 INSTALL HEADLINER SHELF

**4.1 Position Headliner Shelf:** With help, raise up and place your **Headliner Shelf** so that the **front edge** rests on the **visors** of the van (**FIG 13**) and the **rear flange** rests the **B-Pillar Bracket** flanges as shown in **FIG 14**.

**NOTE** - You can mount the shelf so that the brackets sit underneath as well, we just think it looks better with them hidden.

**4.2 Install Headliner Shelf:** Use the supplied **1/4-20" Screws, Flat Washers, And Nylon Locknuts** to loosely install the **Headliner Shelf** to the **Brackets** in the stacking configuration shown in **FIG 15**. Notice that there is a fair amount of adjustment built in to the shelf and brackets (**FIG 16**). Position the shelf so that it is as far **forward** as possible and **centered** in the upper cavity of the van.

**4.3 Secure Headliner Shelf and Tighten Fasteners:** Once you are satisfied with the placement of the shelf, go back and tighten all fasteners used on the shelf and brackets.

**TOOLS REQUIRED FOR THIS STEP:**

- + T25 TORX
- + T30 TORX
- + 5/32" ALLEN WRENCH
- + 7/16" WRENCH OR SOCKET



FIG 13

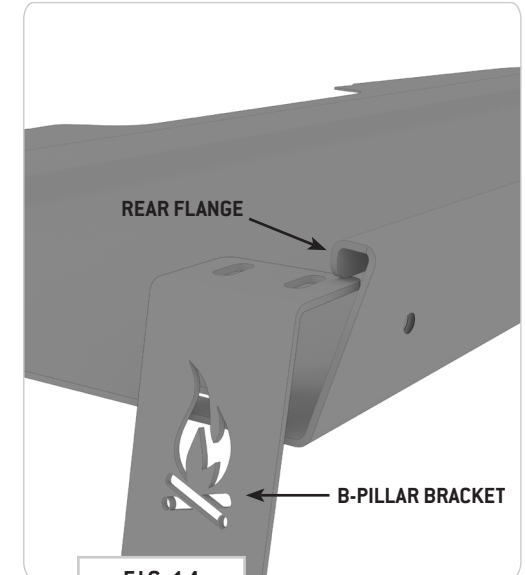

FIG 14

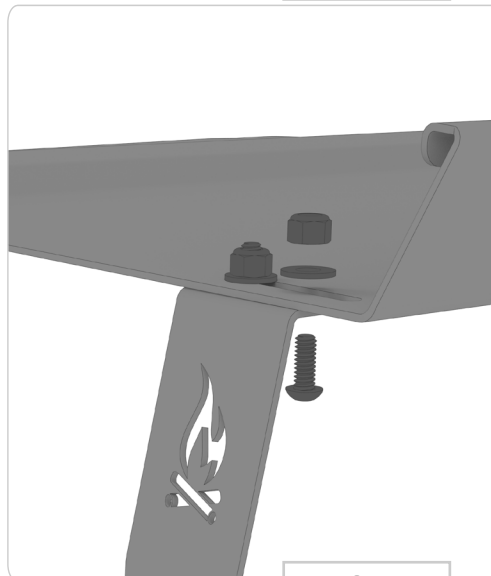

FIG 15



FIG 16



TOOLS REQUIRED FOR THIS STEP: + 5/32" ALLEN WRENCH

## STEP | 05 ASSEMBLE CURTAIN ROD

**5.1 Assemble Curtain Rod:** Use (1ea) 1/4-20 X 0.75" Flanged Button Head Screws with Loctite to install Driver and Passenger Side Brackets on the end of the Curtain Rod Weldment (FIG 17). Align the brackets so the mounting faces are parallel (FIG 18) and tighten the screws.

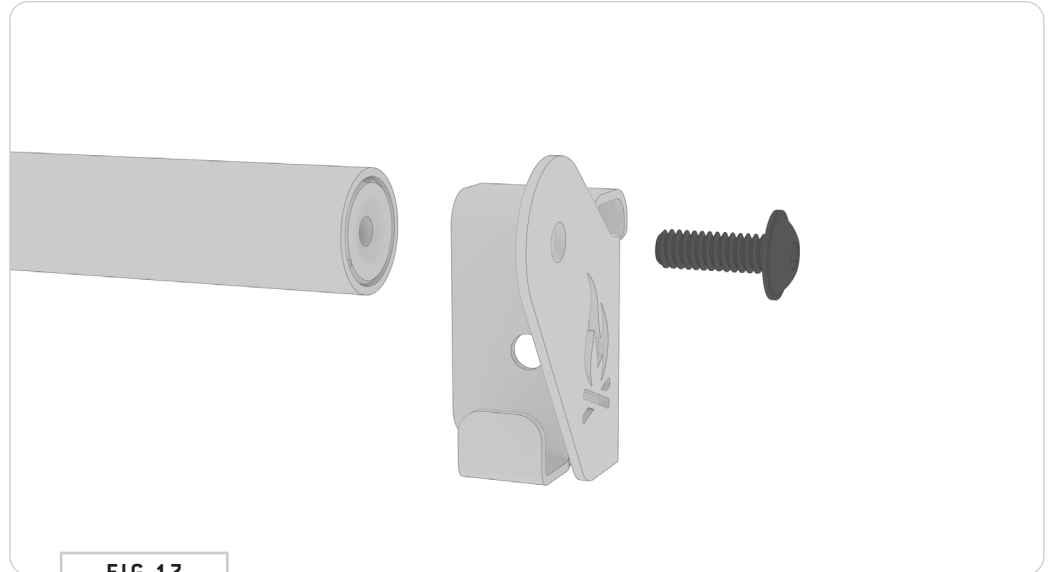

FIG 17

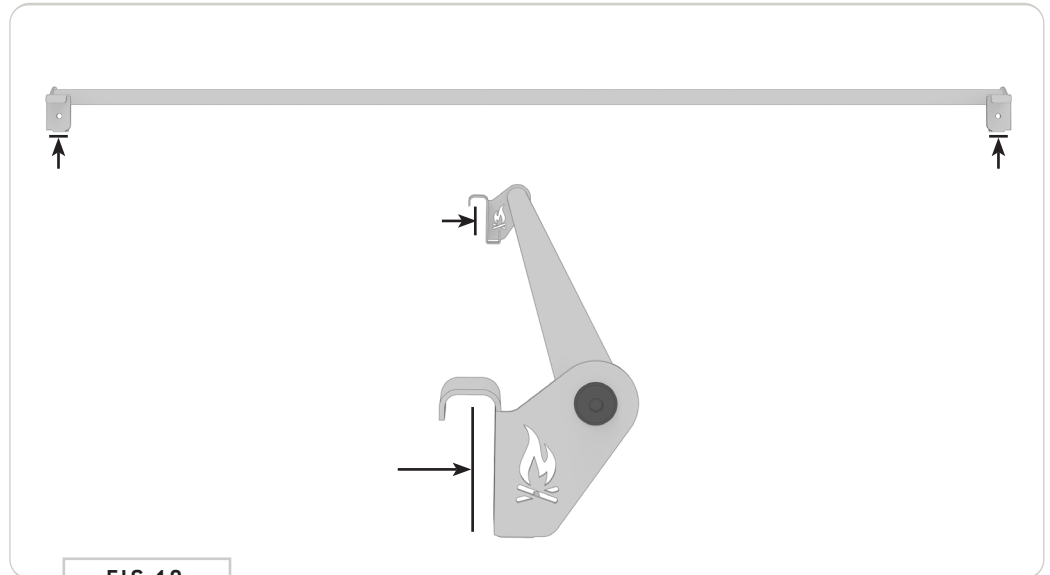

FIG 18

## STEP | 06 INSTALL CURTAIN ROD

**6.1 Position Curtain Rod:** Hang the **Curtain Rod** on the **Headliner Shelf** (FIG 19). Position the **Curtain Rod** so that it is centered.

**6.2 Mark Headliner Shelf for Drilling:** Mark through the mounting holes of the **Curtain Rod** onto the **Headliner Shelf Flange** (FIG 20).

**6.3 Drill Mounting Holes:** Remove the **Curtain Rod** and drill through the **Headliner Shelf Flange** in the locations marked from the last step (FIG 21).

**6.4 Install Curtain Rod to Headliner Shelf:** Hang the **Curtain Rod** back onto the **Headliner Shelf**. Put remaining **Screws** through the drilled mounting holes and secure with a **Flat Washer** and **Nylon Locknut** (FIG 22).

### TOOLS REQUIRED FOR THIS STEP:

- + POWER DRILL
- + MARKER
- + 7/16" WRENCH OR SOCKET
- + 9/32" DRILL BIT
- + 5/32" ALLEN WRENCH

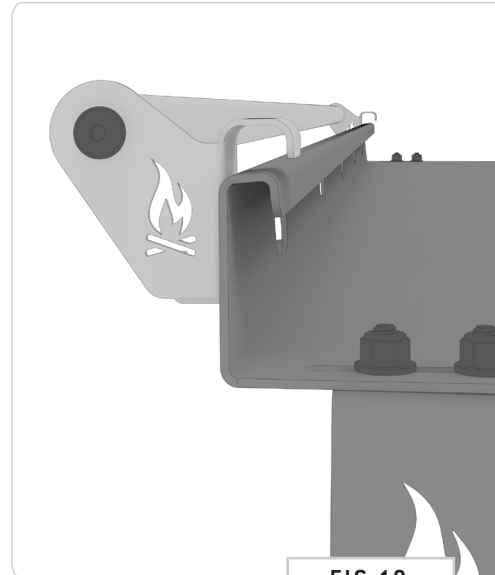

FIG 19

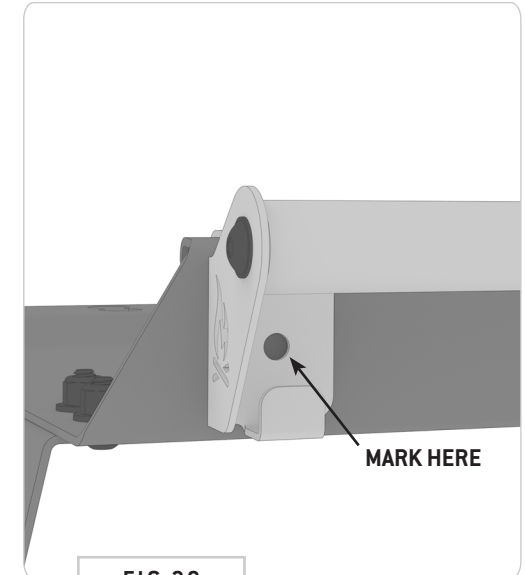

FIG 20

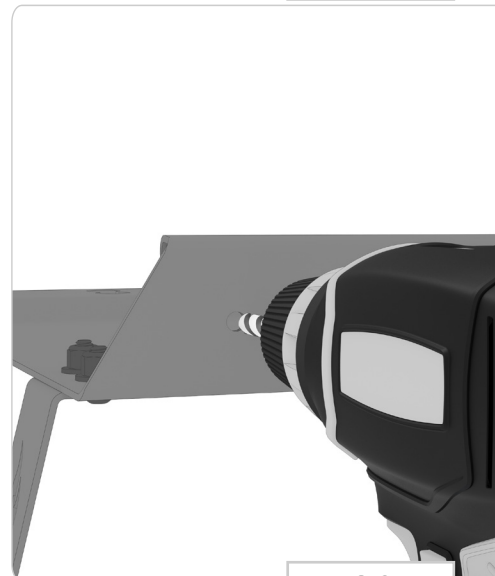

FIG 21

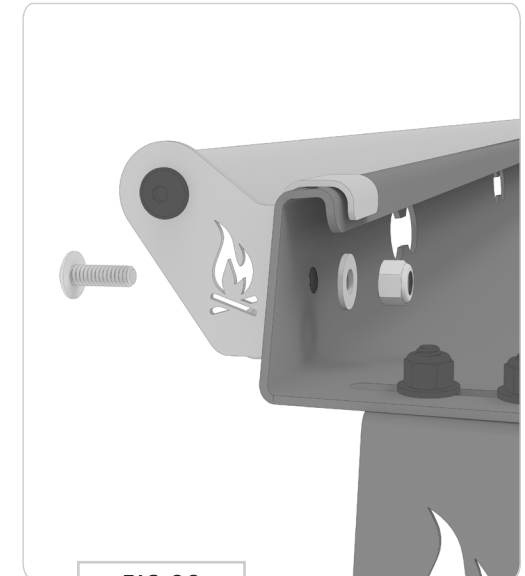

FIG 22

# GET OUT AND EXPLORE!

## + LEAVE US A REVIEW

---

Happy with your new FVC product? We would love to hear (and see) from you! Head to the product page and click "Leave Review." Add a short review and upload a few photos to be showcased on the product page.

## + SHARE YOUR PICS

---

We love seeing how our customers use their FVC products and following along with your adventures. Tag us in your photos with: @flatlinevanco or send them to us via email. We love posting customer pictures in our feed!

## + NEED ANY HELP?

---

If you are having any issues with your product, please reach out, and we will make it right. FVC is a company of van and outdoor enthusiasts that design and use our own products, so we want you to be as stoked on your new parts as we are!



@FLATLINEVANCO