



INSTALLATION GUIDE

SPRINTER VAN ANGLED SHELVES

SP5012B + SP5013B



TOOLS REQUIRED (NOT INCLUDED)

- + 9/32" DRILL BIT
- + POWER DRILL
- + IMPACT DRIVER
- + PHILLIPS HEAD BIT
- + 7/16" WRENCH OR SOCKET

INSTALL INFO

TIME TO INSTALL THIS PRODUCT: 30 MINUTES

Additional help is suggested for a few of the install steps.

BEFORE YOU START

Please inspect the product and packaging upon delivery to ensure there are no issues and that all parts and hardware are accounted for.

Contact us ASAP if anything is missing at:
support@flatlinevanco.com

BEFORE YOU START

All Flatline Van Co products must be properly assembled and secured before attaching to your vehicle. Improper attachment could result in an automobile accident, and could cause serious bodily injury or death to you or to others involved. You are responsible for assembling and securing Flatline Van Co products to your vehicle, checking the mounting points and attachments prior to use, and regularly inspecting the products for wear and or damage. We always recommend you use a professional to install any aftermarket accessories to your vehicle. If you have no mechanical experience and are not thoroughly familiar with the installation procedures, you must have the product installed by a professional installer or other qualified persons. The responsibility is yours and must be taken seriously for everyone's safety.



PACKAGE CONTENTS

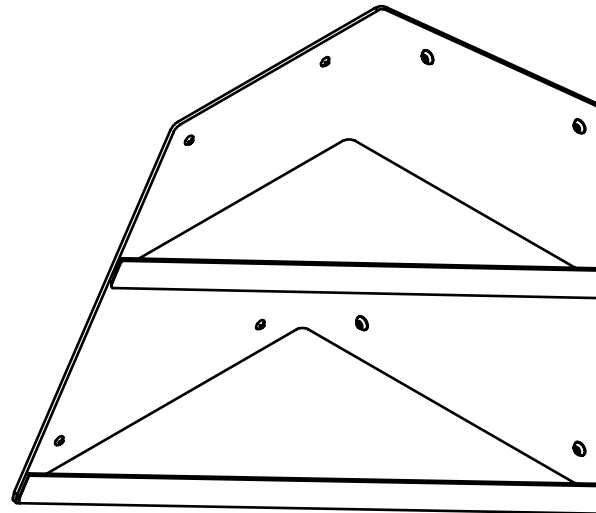

ANGLED SHELF

QTY: 1

HARDWARE

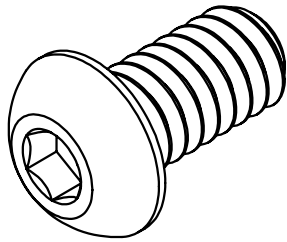

1/4-20 X 0.5 BUTTON HEAD
HEX DRIVE SCREW

QTY: 4

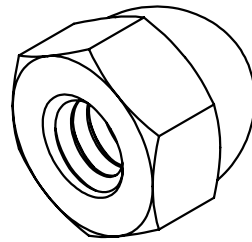

1/4-20 CAP NUT

QTY: 4

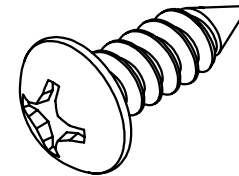

#8 X 0.5 ROUND HEAD
PHILLIPS DRIVE SCREW

QTY: 4

TOOLS REQUIRED FOR THIS STEP:

STEP | 01 LAYOUT AND INSTALL PREP

1.1 Product Compatibility: The Angled Shelves are designed to be installed alongside **24" or 48" FVC Upper Cabinets**. If you are planning to install these to a Cabinet or Structure other than an FVC Cabinet, make sure to dry-fit and double check your fitment before proceeding.

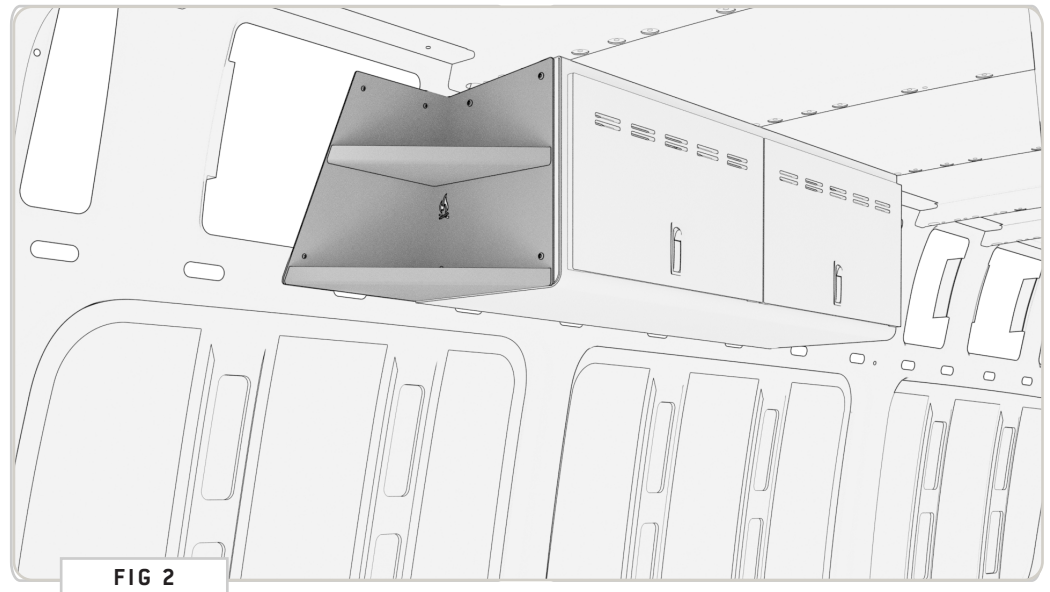
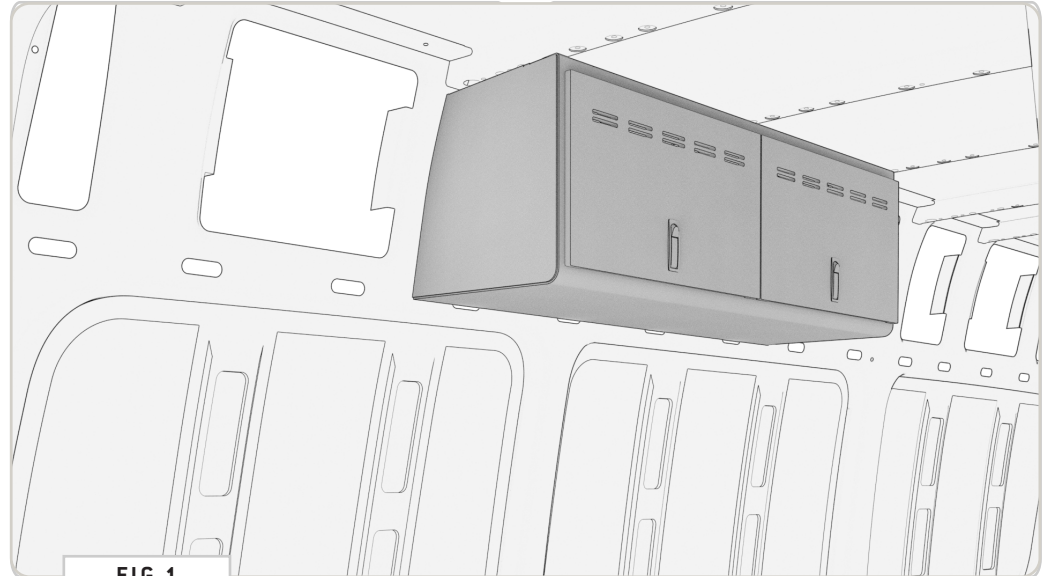

STEP | 01 LAYOUT AND INSTALL PREP

1.2 Mark Drill Holes: Dry-fit the **Angled Shelf** to the side of your **Cabinet**, ensuring that the contours along the back edge are aligned, and mark the holes for drilling (**FIG 3**).

1.3 Drill Out Holes: Drill out holes using a **3/16" Drill Bit**.

TOOLS REQUIRED FOR THIS STEP: + POWER DRILL
+ 9/32" DRILL BIT

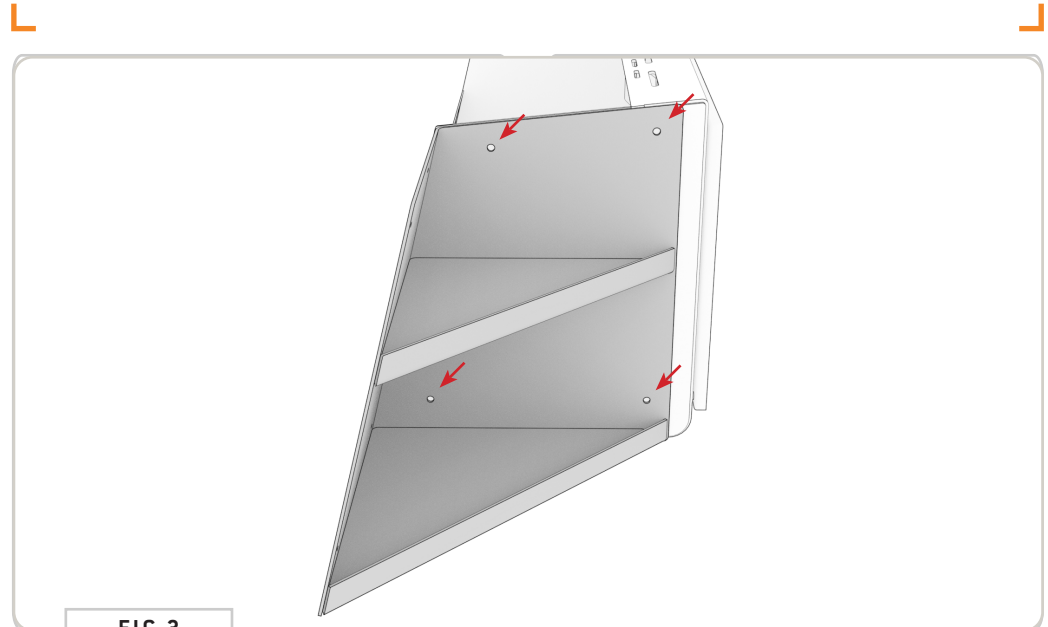

FIG 3

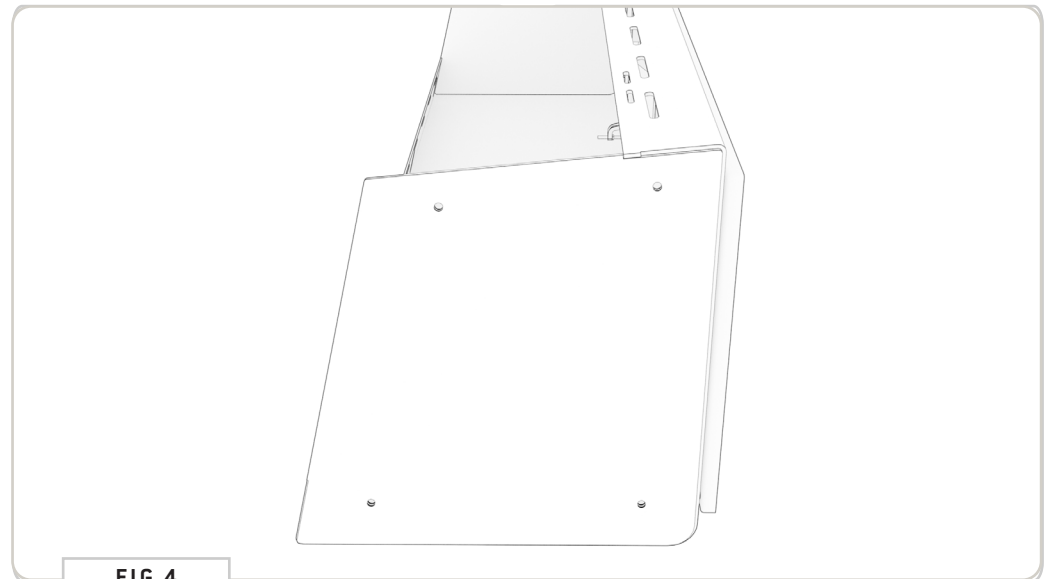

FIG 4

TOOLS REQUIRED FOR THIS STEP: + 5/32" ALLEN WRENCH
+ 7/16" WRENCH OR SOCKET

STEP | 02 INSTALL ANGLED SHELF

2.1 Install Shelf to Cabinet: Use (4) 1/4 x 0.5 Button Head Hex Drive Screws and Cap Nuts to install the Angled Shelf to the Cabinet (FIG 5+6).

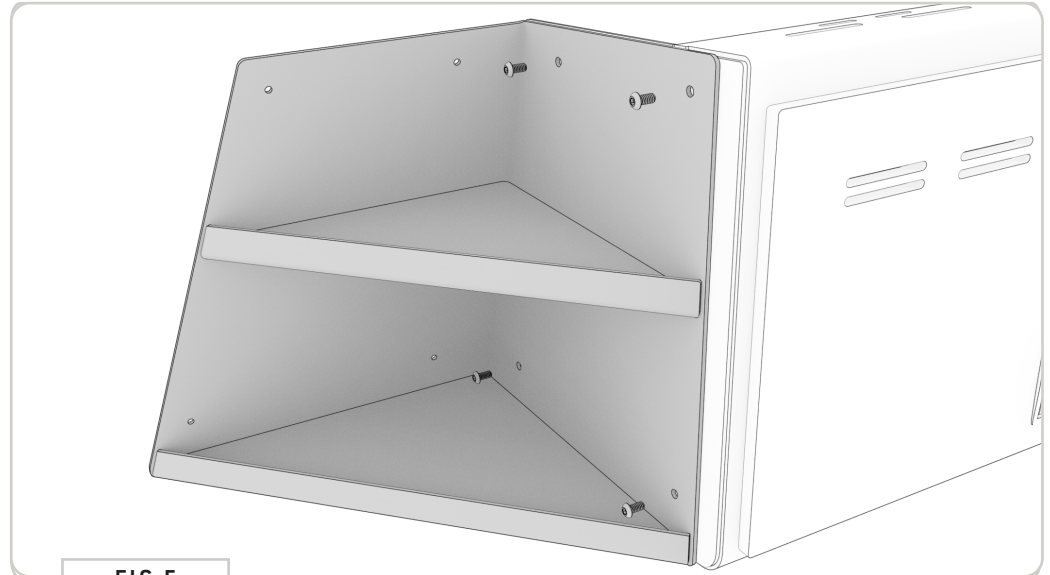

FIG 5

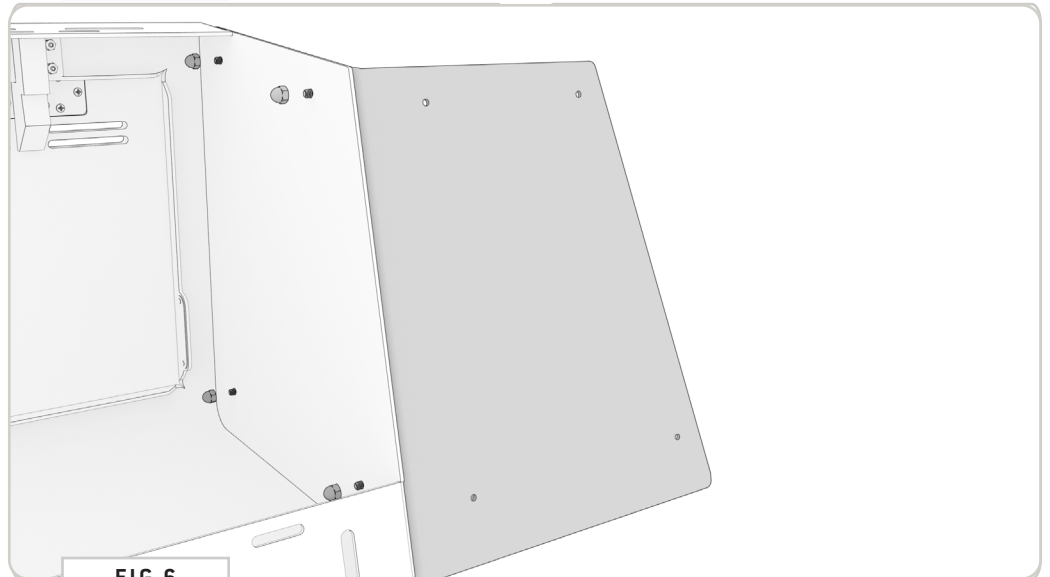

FIG 6

TOOLS REQUIRED FOR THIS STEP: + IMPACT DRIVER
+ PHILLIPS HEAD BIT

STEP | 02 INSTALL ANGLED SHELF

2.2 Secure Shelf to Van: Finish the install by driving (4) #8 X 0.5 Round Head Phillips Drive Screw through the mounting holes shown in FIG 7.

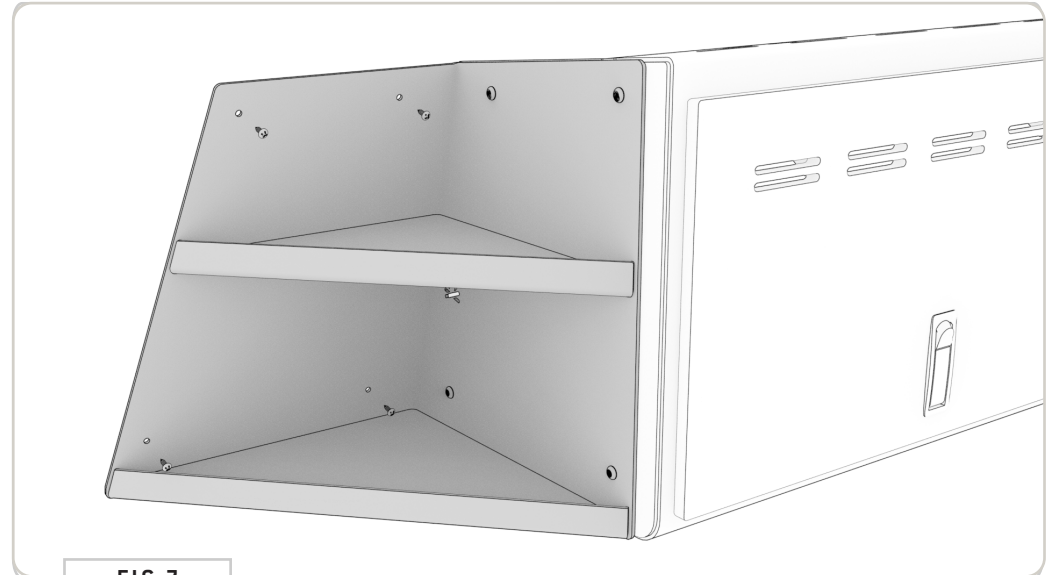

FIG 7



FIG 8

GET OUT AND EXPLORE!

+ LEAVE US A REVIEW

Happy with your new FVC product? We would love to hear (and see) from you! Head to the product page and click "Leave Review." Add a short review and upload a few photos to be showcased on the product page.

+ SHARE YOUR PICS

We love seeing how our customers use their FVC products and following along with your adventures. Tag us in your photos with: @flatlinevanco or send them to us via email. We love posting customer pictures in our feed!

+ NEED ANY HELP?

If you are having any issues with your product, please reach out, and we will make it right. FVC is a company of van and outdoor enthusiasts that design and use our own products, so we want you to be as stoked on your new parts as we are!



@FLATLINEVANCO