



INSTALLATION GUIDE

SPRINTER VAN BULL BAR

SP1153B



TOOLS REQUIRED (NOT INCLUDED)

- + 10MM WRENCH OR SOCKET
- + 13MM WRENCH OR SOCKET
- + 5MM ALLEN WRENCH
- + 5/32" ALLEN WRENCH
- + T45 TORX

INSTALL INFO

TIME TO INSTALL THIS PRODUCT: 30MINS

BEFORE YOU START

Please inspect the product and packaging upon delivery to ensure there are no issues and that all parts and hardware are accounted for.

Contact us ASAP if anything is missing at:
support@flatlinevanco.com

BEFORE YOU START

All Flatline Van Co products must be properly assembled and secured before attaching to your vehicle. Improper attachment could result in an automobile accident, and could cause serious bodily injury or death to you or to others involved. You are responsible for assembling and securing Flatline Van Co products to your vehicle, checking the mounting points and attachments prior to use, and regularly inspecting the products for wear and or damage. We always recommend you use a professional to install any aftermarket accessories to your vehicle. If you have no mechanical experience and are not thoroughly familiar with the installation procedures, you must have the product installed by a professional installer or other qualified persons. The responsibility is yours and must be taken seriously for everyone's safety.



PACKAGE CONTENTS

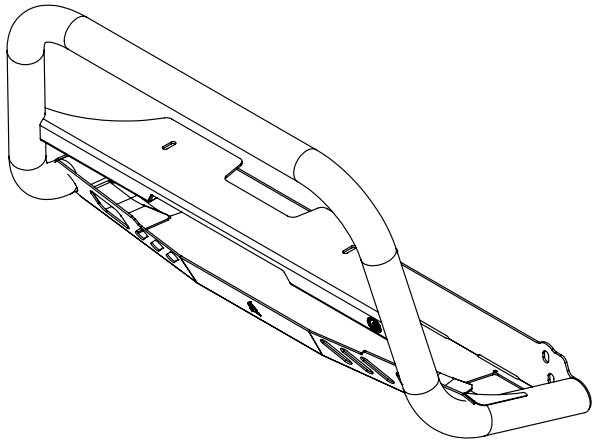

BULL BAR

QTY: 1

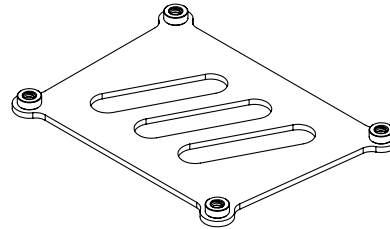

RIGHT SIDE ACCESS PANEL

QTY: 1

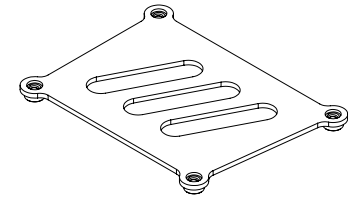

LEFT SIDE ACCESS PANEL

QTY: 1

HARDWARE

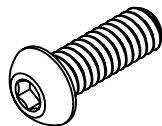

1/4-20 X 0.75 BUTTON HEAD HEX
DRIVE SCREWS

QTY: 8

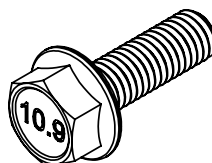

M8-1.25 X 25 FLANGED
GRADE 10.9 HEX HEAD
SCREW

QTY: 4

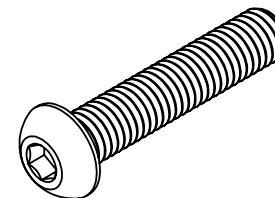

M8-1.25 x 40MM BUTTON
HEAD HEX DRIVE SCREW

QTY: 2

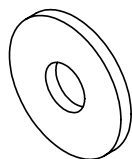

M8 SCREW X 24 O.D.
OVERSIZED FLAT WASHER

QTY: 2

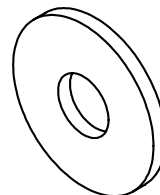

M8 SCREW X 24 O.D.
OVERSIZED GRADE 10.9
FLAT WASHER

QTY: 4

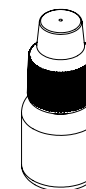

THREADLOCKER

QTY: 1

TOOLS REQUIRED FOR THIS STEP:

STEP | 01 LAYOUT AND INSTALL PREP

1.1 Verify Vehicle Configuration: Before the install of your **Bull Bar**, ensure your van has the required over run brackets installed (**FIG 1**). These provide the necessary mounting points for the bull bar's fitment to the van.

1.2 Install Required Brackets (If Missing): If your van does not have these brackets, you will need to purchase and install the **SP1158B Sprinter Frame Rail Support Brackets** before proceeding with the bull bar.

1.3 Remove License Plate Cover: If your van is equipped with a European-style license plate cover (**FIG 2**), remove it now.

NOTE - If you purchased a **Skid Plate** to install alongside your **Bull Bar**, make sure you install that first.



FIG 1



FIG 2

TOOLS REQUIRED FOR THIS STEP: + T45 TORX
+ 13MM WRENCH OR SOCKET

STEP | 02 REMOVE OEM COMPONENTS

2.1 Remove Over Run Crossbar: Using a **13MM Socket Or Wrench**, remove the factory over run crossbar if it is currently installed on your van (**FIG 3-4**).

2.2 Remove Bumper Step Screws: Use a **T45 Torx** bit to remove the existing screws located on the step portion of the front bumper (**FIG 5-6**).



FIG 3



FIG 4



FIG 5

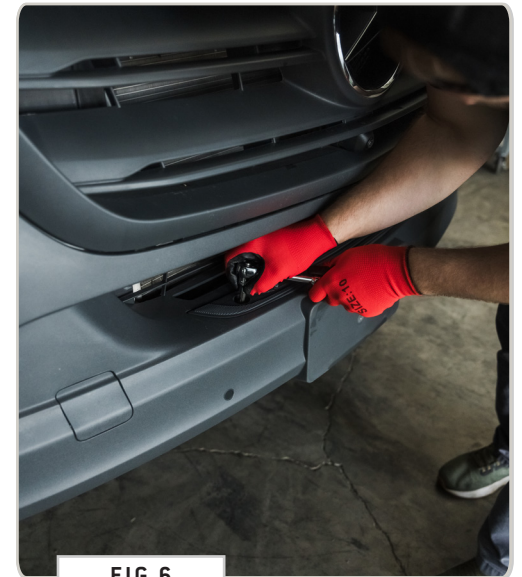

FIG 6

TOOLS REQUIRED FOR THIS STEP:

STEP | 03 PREPARE FVC BULL BAR

3.1 Install Offroad Lighting: If you plan on running lights within the **Bull Bar**, mount them into the light pod cutouts now.

NOTE - These light pods are specifically sized to fit *Baja Designs S2 lights*.

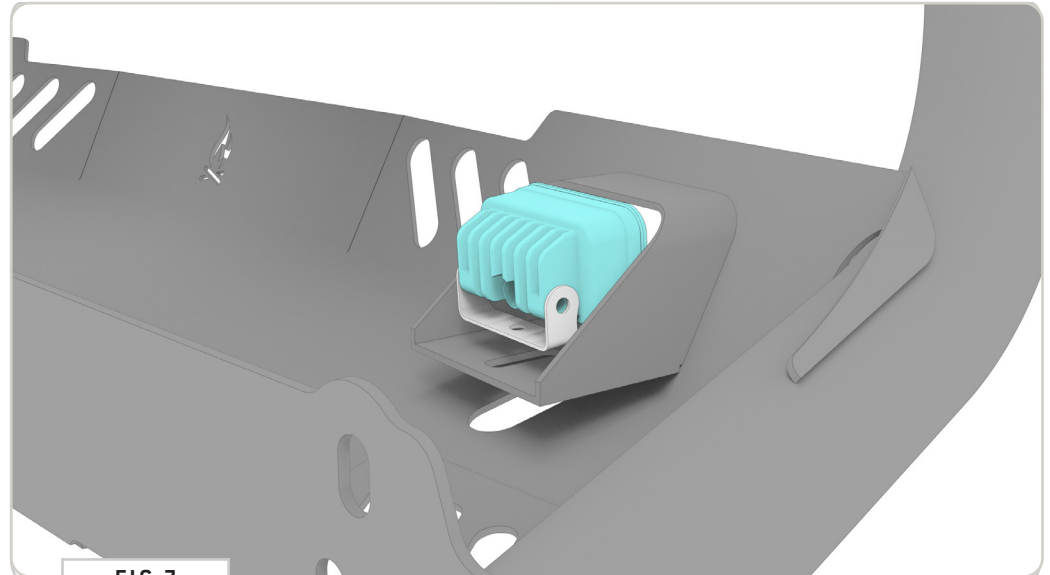

FIG 7

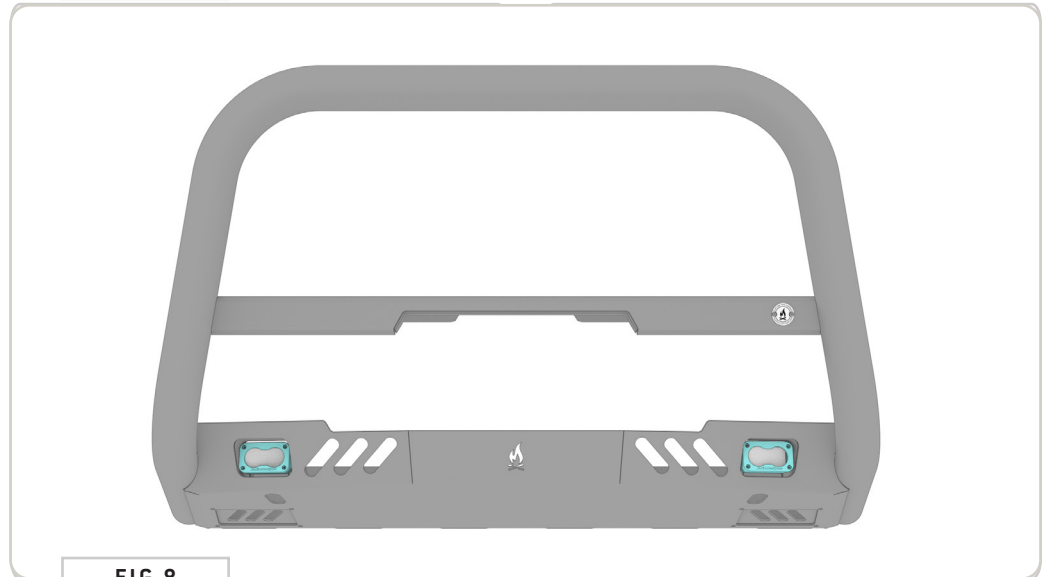

FIG 8

TOOLS REQUIRED FOR THIS STEP:

STEP | 04 INSTALL FVC BULL BAR

4.1 Set the Bar in Place: Carefully fit the **Bull Bar** onto the front bumper. The top bracket should rest on the step portion of the bumper, while the bottom bracket should sit flush against the over run brackets (or front face of **Skid Plate**).

NOTE - The plastic of the Bumper Cover may “catch” on the lower mounting surface of the **Bull Bar**. Simply push it up to gain sufficient clearance.

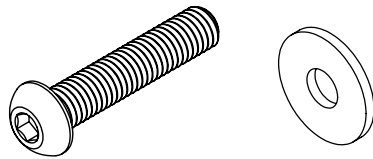

FIG 9



FIG 10

HARDWARE:



TOOLS REQUIRED FOR THIS STEP: + 5MM ALLEN WRENCH

STEP | 04 INSTALL FVC BULL BAR

4.2 Prepare Mounting Screws: Apply threadlocker to the **M8-1.25 X 40MM Button Head Screws**.

4.3 Secure Top Bracket: Thread the screws and black washers through the top bracket and into the factory holes in the bumper step.

4.4 Allow for Adjustment: Keep these screws loose for now so you can adjust the bar's position as you finish the install.

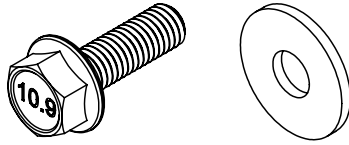

FIG 11



FIG 12

HARDWARE:



TOOLS REQUIRED FOR THIS STEP: + 10MM WRENCH OR SOCKET

STEP | 04 INSTALL FVC BULL BAR

4.5 Locate Access Points: You will access the lower mounting points through the access panels in the bottom of the bull bar.

4.6 Prepare Lower Hardware: Apply threadlocker to the **M8-1.25 X 40MM Button Head Screws**.

4.7 Secure Lower Bracket: Using a **10MM Socket Or Wrench**, install the screws through the **Bull Bar** and into the over run brackets.

4.8 Integrate Skid Plate (Optional): If you are installing a skid plate, sandwich its front bracket between the bull bar and the over run brackets (**FIG 14**). The screws will pass through the bull bar bracket and the skid plate bracket into the over run points. There may be some adjustment necessary in the **Bull Bar/Skid Plate** for the mounting holes to line up.

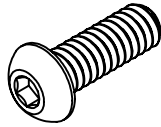

FIG 13



FIG 14

HARDWARE:



TOOLS REQUIRED FOR THIS STEP: + 5MM ALLEN WRENCH

STEP | 05 FINAL CHECKS

5.1 Fully Tighten Top Screws: Use a 5MM Allen Wrench to finish tightening the top screws you installed in Step 4.3.

5.2 Complete Electrical Work: If you mounted lights in Step 3, finish the wiring process now.

5.3 Reinstall Access Panels: Place the access panel covers back onto the Bull Bar and secure using the 1/4-20 X 0.75 Button Head Screws.



FIG 15

GET OUT AND EXPLORE!

+ LEAVE US A REVIEW

Happy with your new FVC product? We would love to hear (and see) from you! Head to the product page and click "Leave Review." Add a short review and upload a few photos to be showcased on the product page.

+ SHARE YOUR PICS

We love seeing how our customers use their FVC products and following along with your adventures. Tag us in your photos with: @flatlinevanco or send them to us via email. We love posting customer pictures in our feed!

+ NEED ANY HELP?

If you are having any issues with your product, please reach out, and we will make it right. FVC is a company of van and outdoor enthusiasts that design and use our own products, so we want you to be as stoked on your new parts as we are!



@FLATLINEVANCO