



INSTALLATION GUIDE

SPRINTER VAN REAR BUMPER

SP1130B



TOOLS REQUIRED (NOT INCLUDED)

- + AUTO PANEL REMOVAL TOOLS
- + 9/16" WRENCH & SOCKET
- + 8MM WRENCH OR SOCKET
- + 18MM WRENCH OR SOCKET
- + 19MM WRENCH OR SOCKET

INSTALL INFO

TIME TO INSTALL THIS PRODUCT: 2-3 HOURS

Additional help is suggested for a few of the install steps.

BEFORE YOU START

Please inspect the product and packaging upon delivery to ensure there are no issues and that all parts and hardware are accounted for.

Contact us ASAP if anything is missing at:
support@flatlinevanco.com

BEFORE YOU START

All Flatline Van Co products must be properly assembled and secured before attaching to your vehicle. Improper attachment could result in an automobile accident, and could cause serious bodily injury or death to you or to others involved. You are responsible for assembling and securing Flatline Van Co products to your vehicle, checking the mounting points and attachments prior to use, and regularly inspecting the products for wear and or damage. We always recommend you use a professional to install any aftermarket accessories to your vehicle. If you have no mechanical experience and are not thoroughly familiar with the installation procedures, you must have the product installed by a professional installer or other qualified persons. The responsibility is yours and must be taken seriously for everyone's safety.



BUMPER PACKAGE CONTENTS

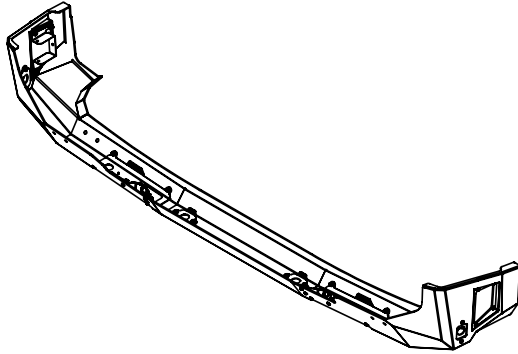

REAR BUMPER ASSEMBLY

QTY: 1

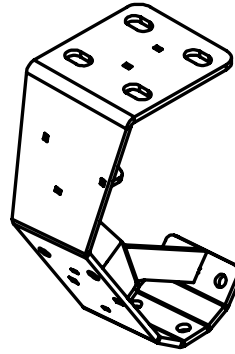

DRIVER SIDE BUMPER BRACKET

QTY: 1

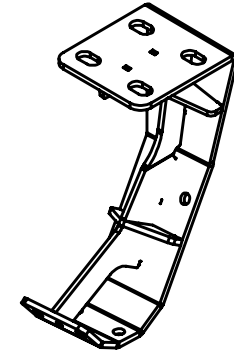

PASSENGER SIDE BUMPER BRACKET

QTY: 1

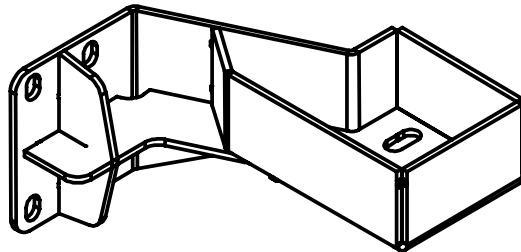

PASSENGER SIDE FRAME BRACKET WELDMENT

QTY: 1

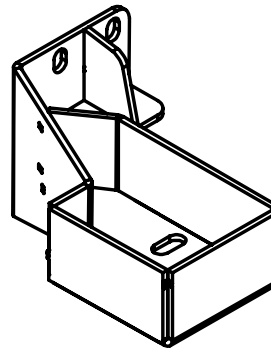

DRIVER SIDE FRAME BRACKET WELDMENT

QTY: 1

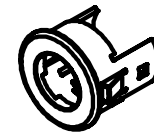

SPRINTER PARK SENSOR BEZEL

QTY: 6

BUMPER HARDWARE

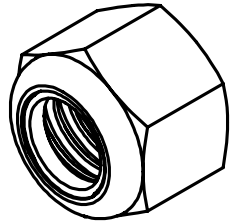

3/8-16 NYLON INSERT
LOCKNUT

QTY: 12

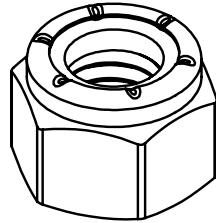

0.5-13 NYLON LOCKNUT

QTY: 8

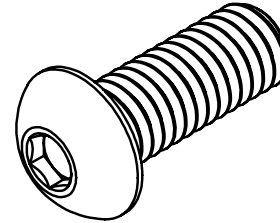

3/8-16 X 1 BUTTON HEAD
HEX DRIVE SCREW

QTY: 12

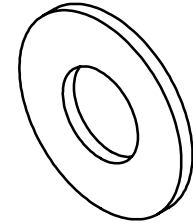

3/8 SCREW FLAT WASHER

QTY: 12

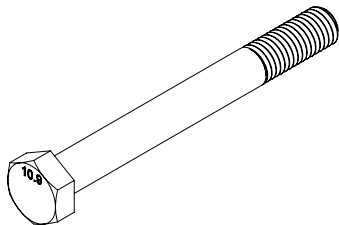

M12-1.75 x 110mm HEX
HEAD SCREW

QTY: 8

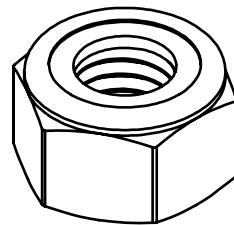

M12-1.75 NYLON
LOCKNUT

QTY: 8

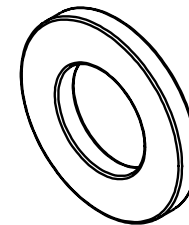

M12 SCREW FLAT
WASHER

QTY: 16

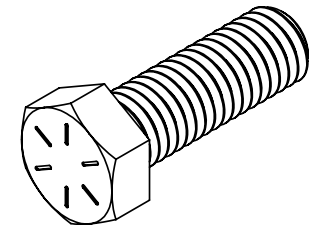

0.5-13 x 1.5 HEX HEAD
SCREW

QTY: 8

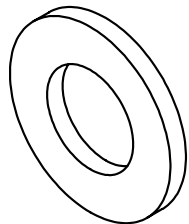

0.5 SCREW FLAT WASHER

QTY: 16

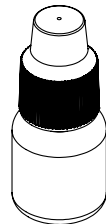

5ML THREADLOCKER
BOTTLE

QTY: 1

INSTALL

STEP | 01 LAYOUT AND INSTALL PREP

1.1 Safety Check: Disconnect battery (both if applicable) prior to performing any electrical work and ensure you are working on a flat surface.

1.2 Review Install Outline: Thoroughly read all instructions and warnings before beginning installation. This product requires modifications to factory parts *done at your own risk*. If you don't feel comfortable installing this on your own, see our **Find a Builder or Upfitter** page to locate an approved installer near you.

1.3 Bumper Accessories: If you plan on running **Off-Road Lights**, waiting to install the **Bumper** until those parts are ready to install as well would be advised.

TOOLS REQUIRED FOR THIS STEP:



FIG 1



FIG 2

TOOLS REQUIRED FOR THIS STEP: AUTO PANEL PRY TOOL

STEP | 02 REMOVE FACTORY BUMPER

2.1 Access Upper Rear Bumper Trim: Using an Auto Panel Pry Tool, unclip the **Rear Side Trim** from the body to gain access to the plastic rivets that hold the **Upper Rear Bumper Trim** to the van body (FIG 3).

2.2 Remove Upper Rear Bumper Trim: Pop out the plastic rivets that secure **Upper Rear Bumper Trim** (under the tail light) to the body (FIG 5). Set the trim piece and plastic rivets aside.

2.3 Repeat On Other Side: Repeat this process for the other side of the van.

PRO-TIP: Use a pry tool to pop the center plastic rivet pin out first before prying from the bottom.

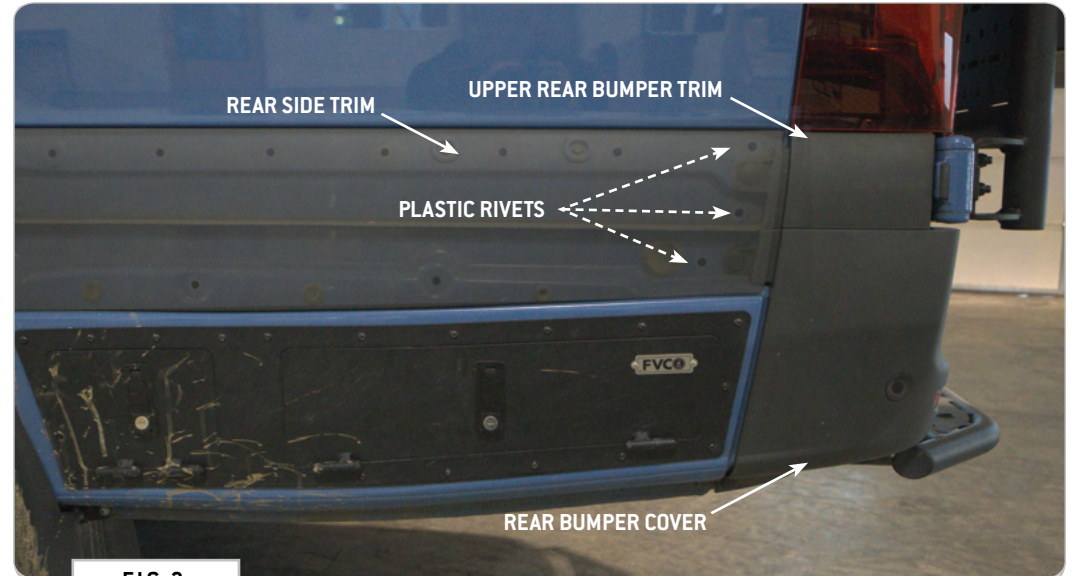
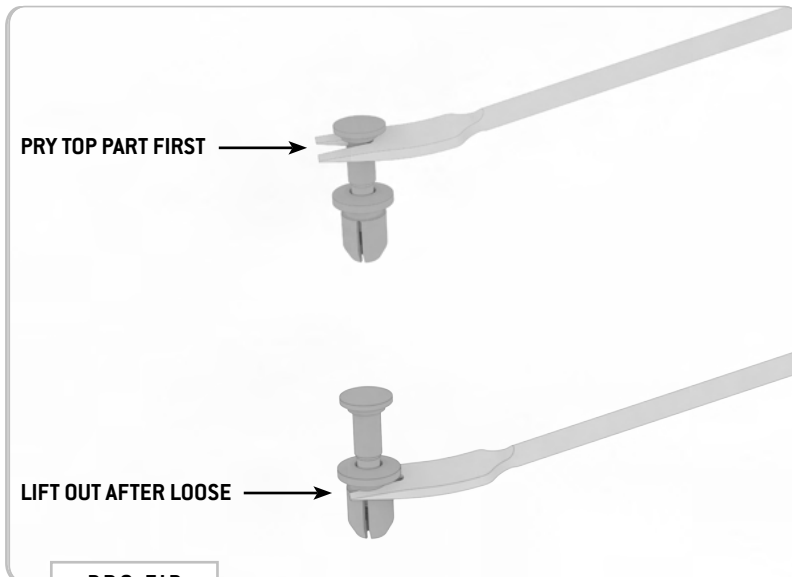

FIG 3



PRO-TIP

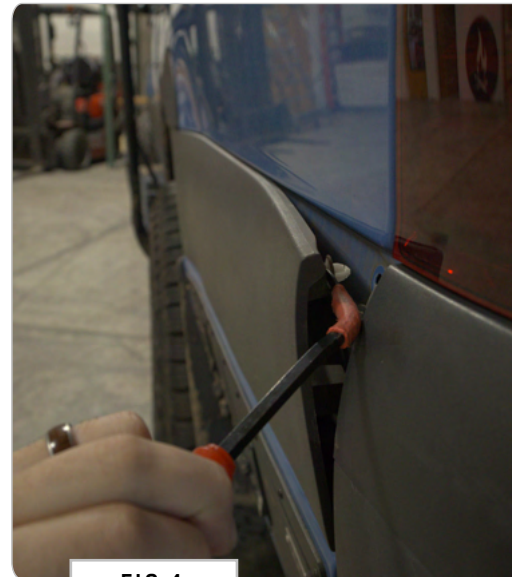

FIG 4

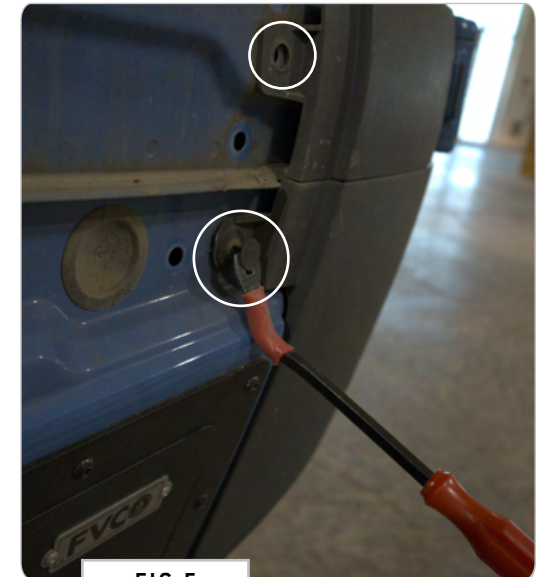

FIG 5

TOOLS REQUIRED FOR THIS STEP: + AUTO PANEL PRY TOOL

STEP | 02 REMOVE FACTORY BUMPER

2.4 Underside Plastic Rivets and Clips: Remove the plastic rivets and clips on the lower side of the bumper cover. There are two rivets on each outer side, two clips on the corners and two more rivets toward the center of the **Factory Bumper Cover** (FIG 6-8).



FIG 6



FIG 7



FIG 8

- TOOLS REQUIRED FOR THIS STEP:**
- + T40 TORX
 - + RATCHET
 - + RATCHET EXTENSION
 - + FLATHEAD SCREWDRIVER

STEP | 02 REMOVE FACTORY BUMPER

2.5 Remove Torx Bolts: Remove the (7) Torx Bolts holding the **Factory Bumper Cover** to the body. These are located just under the rear door weather strip and become visible once you open the rear doors (**FIG 9-10**).

2.6 Unclip Sensor Harness: Using a **Flathead Screwdriver**, gently pry up the tabs holding together the **Sensor Harness** to the **Bumper Cover**. Proceed to disconnect (**FIG 11**).

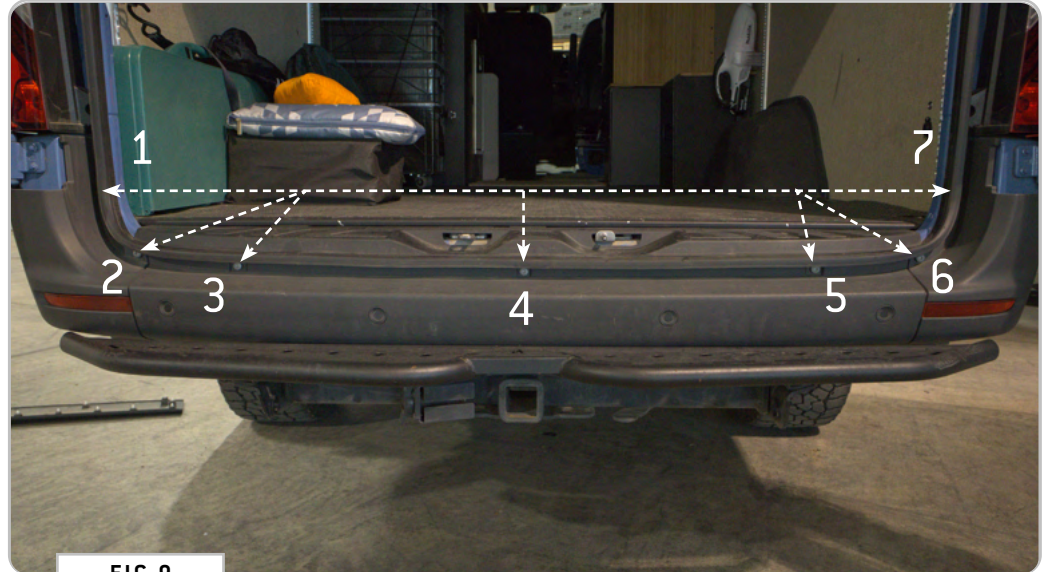

FIG 9



FIG 10

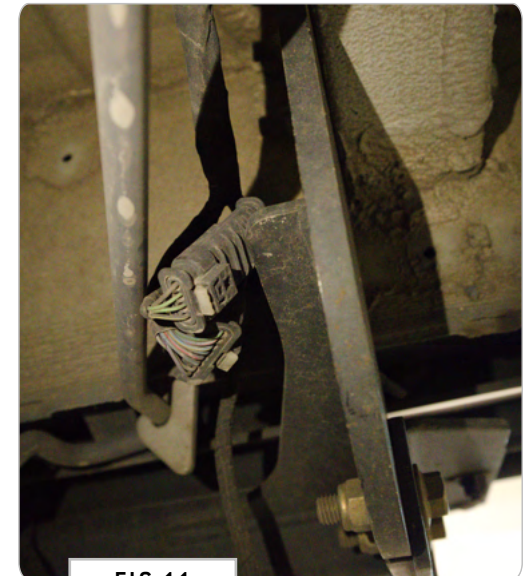

FIG 11

TOOLS REQUIRED FOR THIS STEP:

- + T40 TORX
- + RATCHET
- + RATCHET EXTENSION

STEP | 02 REMOVE FACTORY BUMPER

2.7 Remove Factory Bumper Cover: The bumper cover can now be removed. Take care to note the orientation and position of the park sensors, as they will need to be reinstalled to the new bumper as they were in the **Factory Bumper Cover**.

2.8 Remove Wiring Harness: Starting with the **Blind Spot Radar Sensors (FIG 12)**, pry out all of the **Park Sensors** from their **Factory Bezels (FIG 13)**, keeping the entire harness connected as an assembly.

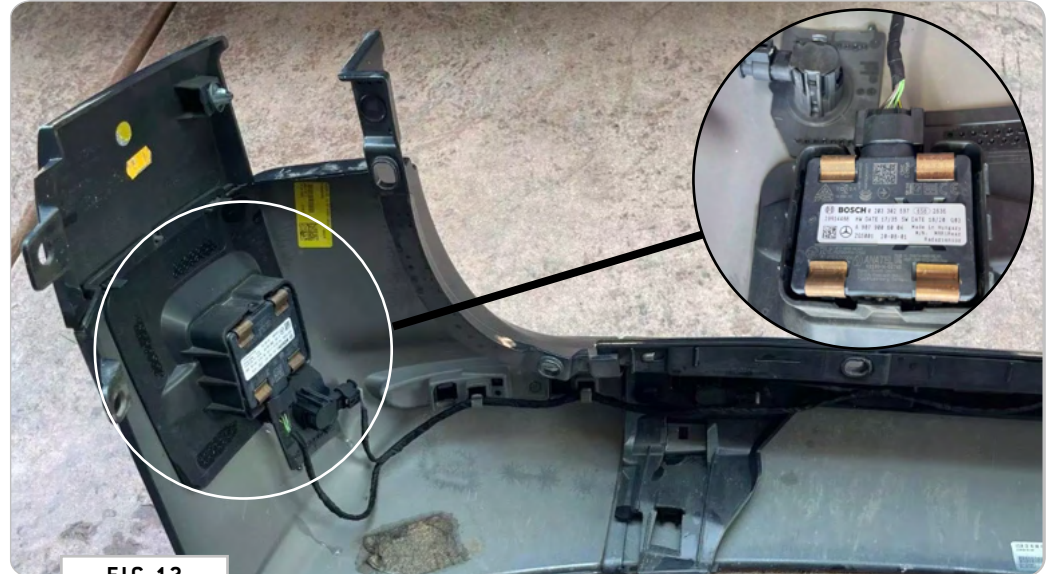

FIG 12



FIG 13

STEP | 03 PREP FVC BUMPER INSTALL

3.1 Install Bumper Brackets: Install the Driver and Passenger Side Bumper Brackets using (6ea) 3/8-16 x0.75 Button Head Hex Drive Screws, Flat Washers and Nylon Locknuts (FIG 14-15).

TOOLS REQUIRED FOR THIS STEP: + 7/32" ALLEN WRENCH
+ 9/16" WRENCH OR SOCKET

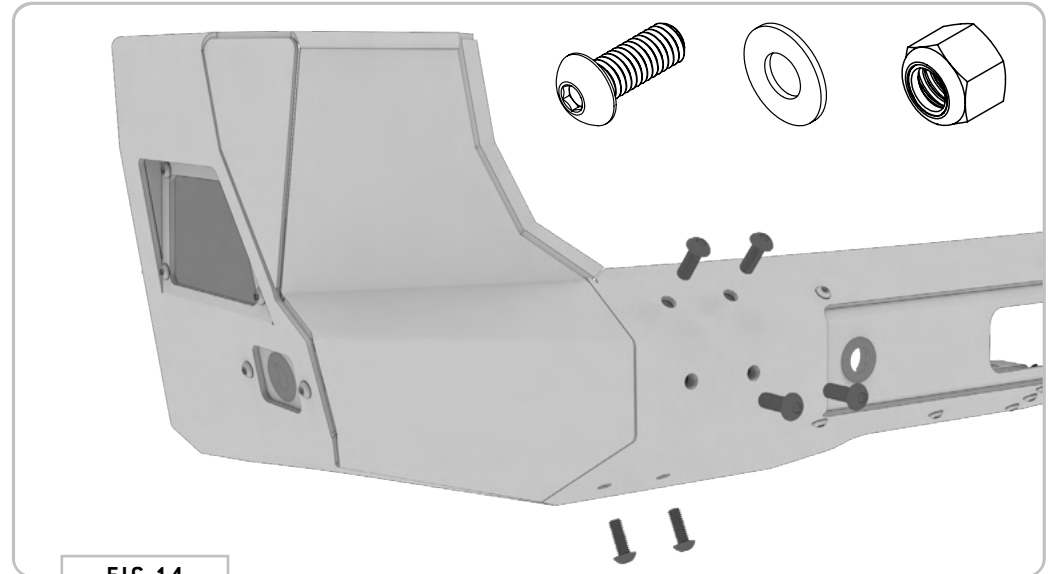

FIG 14

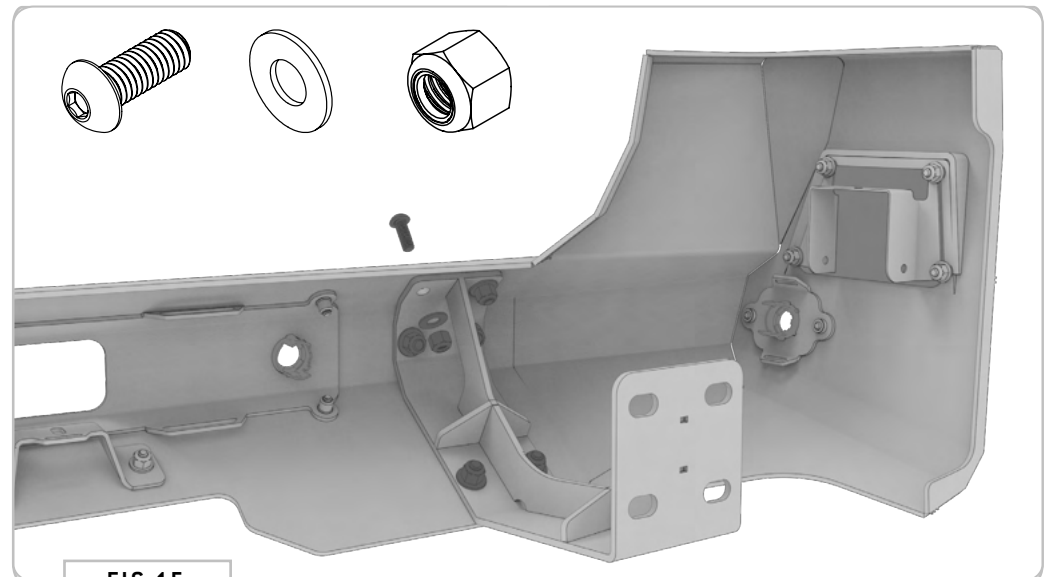

FIG 15

TOOLS REQUIRED FOR THIS STEP:

STEP | 03 PREP FVC BUMPER INSTALL

3.2 Install Park Sensor Bezels: Install the plastic **Park Sensor Bezels** to the locations shown in FIG 16. Install by aligning the notches in the **Park Sensor Bezel** to the cutouts in the **Bumper** (FIG 17).

NOTE - The orientation of the **Bezel** corresponds to the direction in which the **Park Sensor** will be installed. See FIG 17 to observe how the molding of the **Park Sensor** aligns to the cutouts in the **Bezel**.

3.3 Reinstall Upper Rear Bumper Trim: Using the **Plastic Rivets** that you retained in **Step 2.2**, secure the small plastic cover (below the taillights) back to the body (FIG 18).

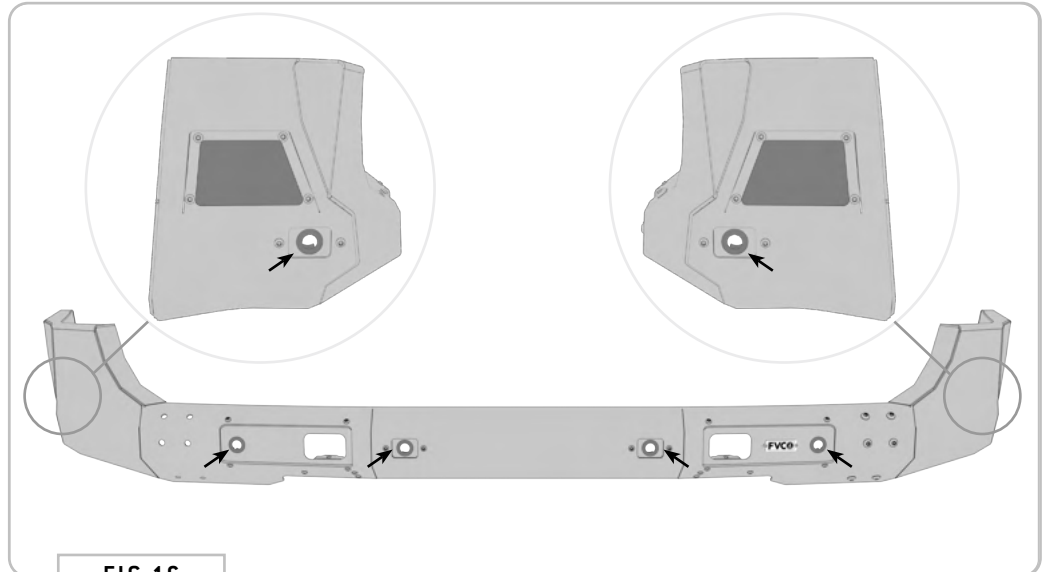

FIG 16

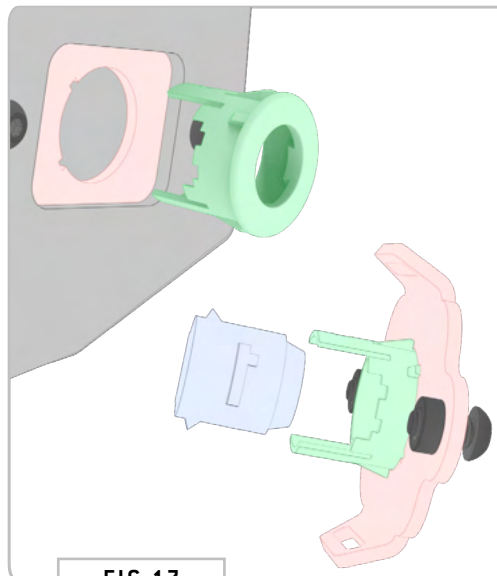

FIG 17

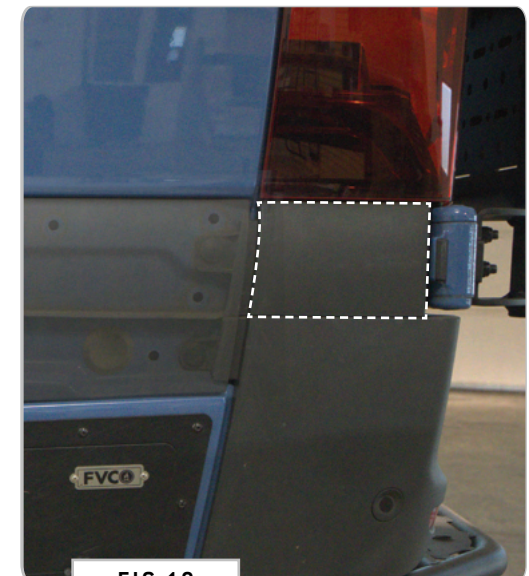

FIG 18

TOOLS REQUIRED FOR THIS STEP:

STEP | 03 PREP FVC BUMPER INSTALL

3.4 Install Blind Spot Sensor (Passenger Side): Install the Blind Spot Sensor to the bracket shown in FIG 19.

3.5 Install Park Sensors to Park Sensor Bezels (Passenger Side): Install the Park Sensors to the Park Sensor Bezels in the orientation that they were removed as shown in FIG 20.

NOTE - There are multiple zip tie locations along the **Park Sensor Bezel Brackets** to keep the **Park Sensor Harness** held securely to the new **Bumper**. See **FIG 19-20** for examples.



FIG 19

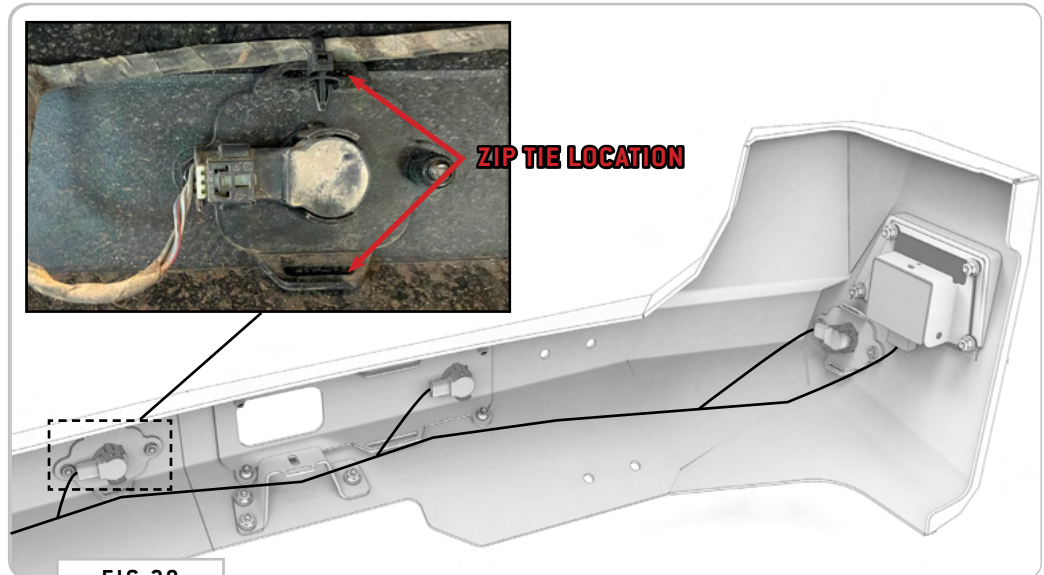

FIG 20

STEP | 03 PREP FVC BUMPER INSTALL

3.6 Install Blind Spot Sensor (Driver Side): Install the **Blind Spot Sensor** to the bracket shown in FIG 21.

3.7 Install Park Sensors to Park Sensor Bezels (Driver Side): Install the **Park Sensors** to the **Park Sensor Bezels** in the orientation that they were removed as shown in FIG 22.

NOTE - There are multiple zip tie locations along the **Park Sensor Bezel Brackets** to keep the **Park Sensor Harness** held securely to the new **Bumper**. See FIG 21-22 for examples.

TOOLS REQUIRED FOR THIS STEP:

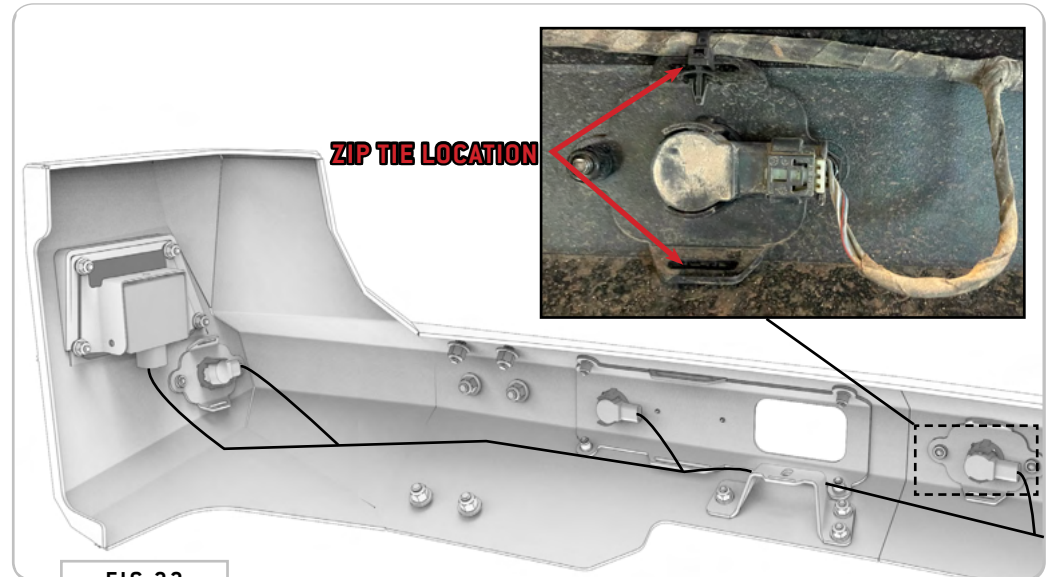
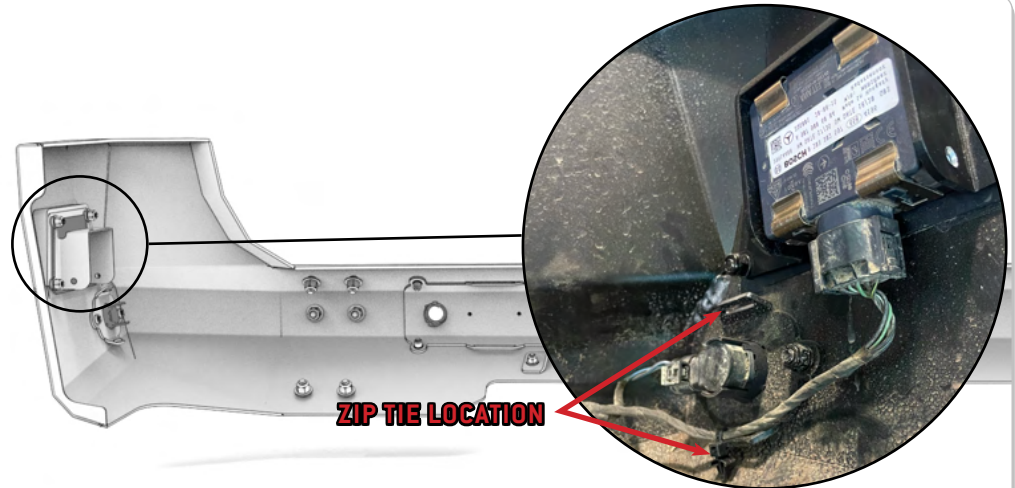

TOOLS REQUIRED FOR THIS STEP:

STEP | 03 PREP FVC BUMPER INSTALL

3.8 Install Off-Road Lights (Optional): If you purchased **Off-Road Lights** for this **Rear Bumper**, install them to the **Light Brackets** shown in FIG 23-24 at this time.

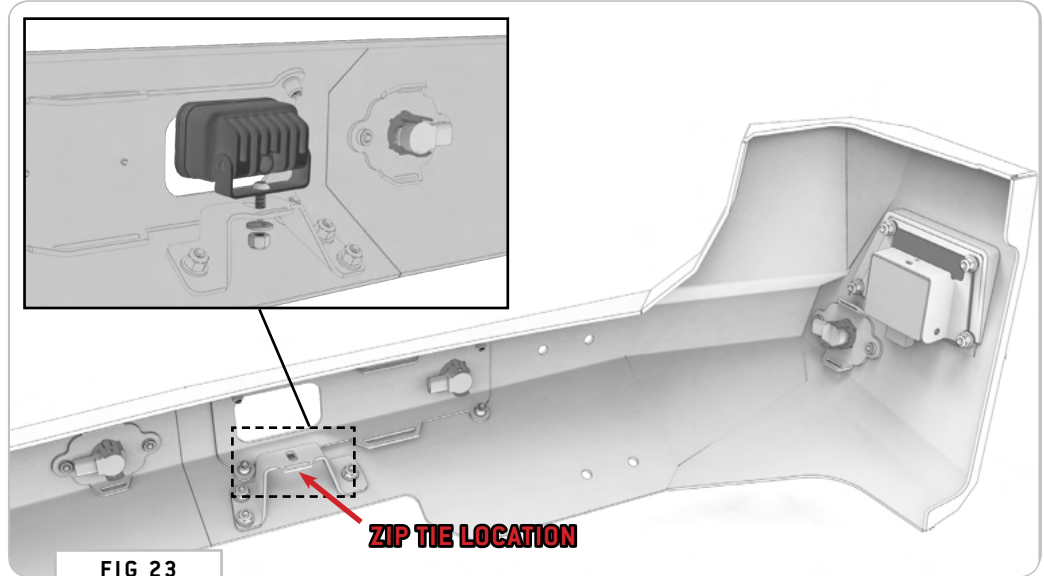

FIG 23

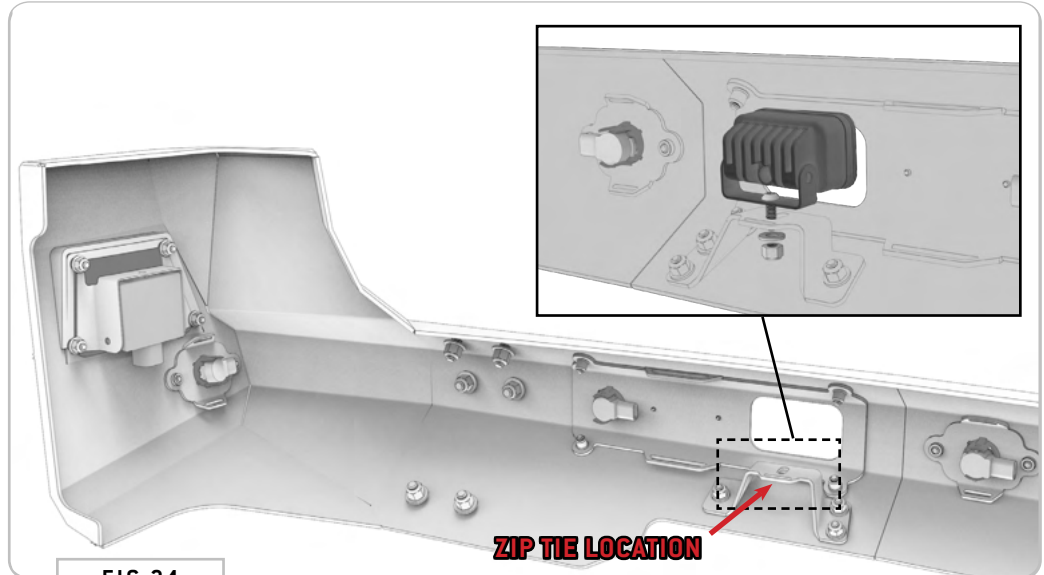

FIG 24

TOOLS REQUIRED FOR THIS STEP: + 18MM WRENCH OR SOCKET
+ 19MM WRENCH OR SOCKET

STEP | 04 FVC BUMPER INSTALL

4.1 Install Van Frame Brackets: Install the Van Frame Brackets to the locations shown in FIG 25-26 by removing the factory bolts and replacing them one-at-a-time with **M12-1.75 x 110mm Hex Head Screws, Flat Washers and Nylon Locknuts.**

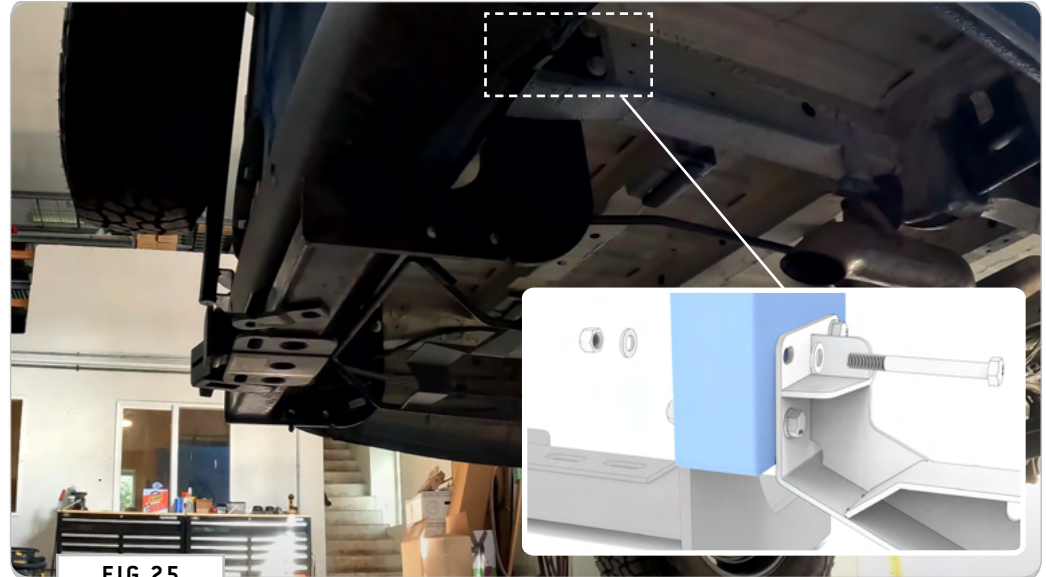

FIG 25



FIG 26

TOOLS REQUIRED FOR THIS STEP: + 8MM WRENCH OR SOCKET

STEP | 04 FVC BUMPER INSTALL

4.2 Install Rear Bumper to Van Frame Brackets: Install the Rear Bumper to the Van Frame Brackets using (4ea) 0.5-13 x 1.5 Hex Head Screws, Flat Washers and Nylon Locknuts (FIG 27-28). Reattach the Park Sensor Harness to the van and enjoy your new Rear Bumper!

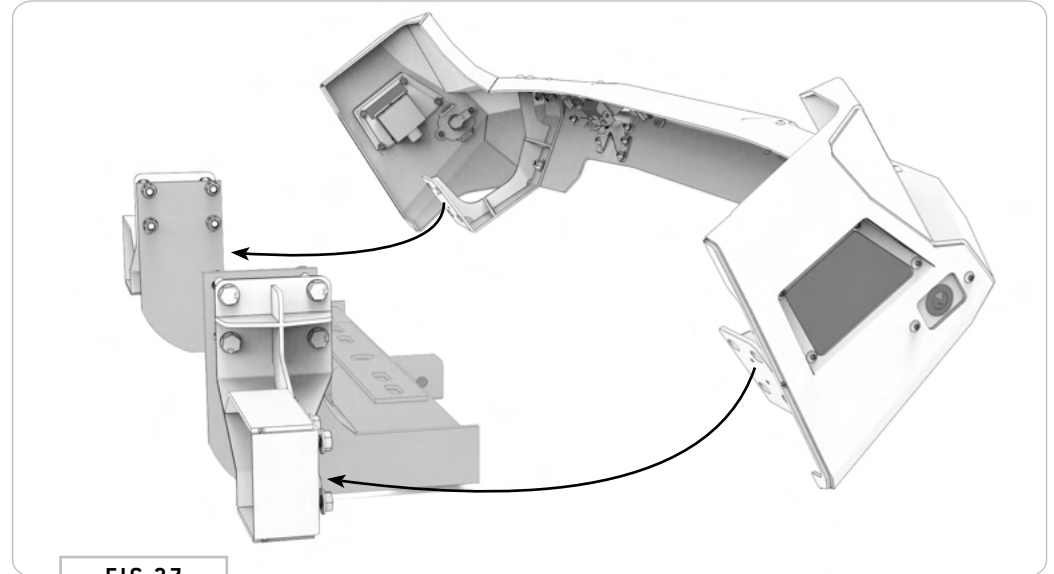

FIG 27

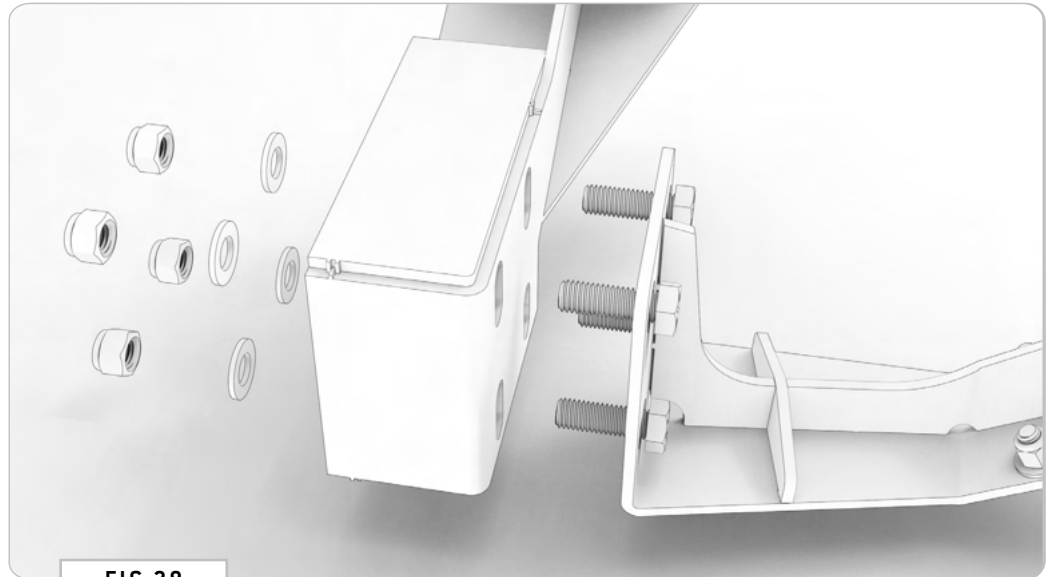

FIG 28

GET OUT AND EXPLORE!

+ LEAVE US A REVIEW

Happy with your new FVC product? We would love to hear (and see) from you! Head to the product page and click "Leave Review." Add a short review and upload a few photos to be showcased on the product page.

+ SHARE YOUR PICS

We love seeing how our customers use their FVC products and following along with your adventures. Tag us in your photos with: @flatlinevanco or send them to us via email. We love posting customer pictures in our feed!

+ NEED ANY HELP?

If you are having any issues with your product, please reach out, and we will make it right. FVC is a company of van and outdoor enthusiasts that design and use our own products, so we want you to be as stoked on your new parts as we are!



@FLATLINEVANCO