



INSTALLATION GUIDE

SPRINTER VAN FRONT BUMPER

SP1127B



TOOLS REQUIRED (NOT INCLUDED)

- | | |
|--------------------------|---------------------------|
| + 1/4" RATCHET | + 3/4" SOCKET |
| + 3/8" RATCHET | + 9/16" SOCKET AND WRENCH |
| + T25 TORX | + 7/16" SOCKET AND WRENCH |
| + T30 TORX | + 3/8" SOCKET AND WRENCH |
| + 7/32" ALLEN WRENCH | + 13MM SOCKET |
| + 5/32" ALLEN WRENCH | + POWER DRILL |
| + AUTO TRIM REMOVAL TOOL | + BODY SAW |
| + SNAP RING PLIERS | + PAINTERS TAPE |
| + SIDE CUTTERS | + MARKER |
| + 12" EXTENSION | + TAPE MEASURE |
| + 4" EXTENSION | |

INSTALL INFO

TIME TO INSTALL THIS PRODUCT: 5-6 HOURS

Additional help is suggested for a few of the install steps.

BEFORE YOU START

Please inspect the product and packaging upon delivery to ensure there are no issues and that all parts and hardware are accounted for.

Contact us ASAP if anything is missing at:
support@flatlinevanco.com

BEFORE YOU START

All Flatline Van Co products must be properly assembled and secured before attaching to your vehicle. Improper attachment could result in an automobile accident, and could cause serious bodily injury or death to you or to others involved. You are responsible for assembling and securing Flatline Van Co products to your vehicle, checking the mounting points and attachments prior to use, and regularly inspecting the products for wear and or damage. We always recommend you use a professional to install any aftermarket accessories to your vehicle. If you have no mechanical experience and are not thoroughly familiar with the installation procedures, you must have the product installed by a professional installer or other qualified persons. The responsibility is yours and must be taken seriously for everyone's safety.



BUMPER PACKAGE CONTENTS

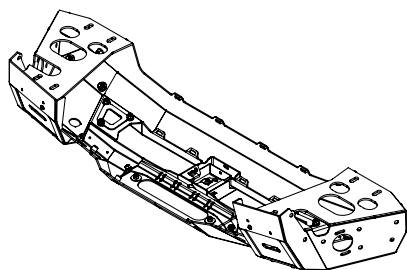

CENTER WELDMENT

QTY: 1

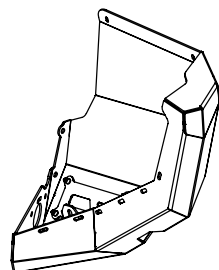

PASSENGER SIDE WING

QTY: 1

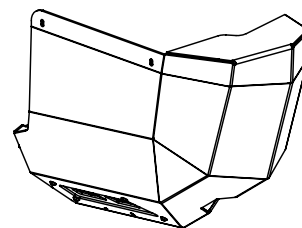

DRIVER SIDE WING

QTY: 1

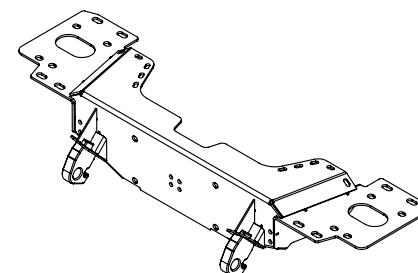

WINCH CRADLE

QTY: 1

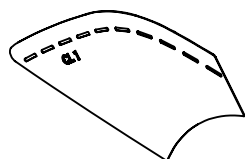

CUT TEMPLATE 1

QTY: 1

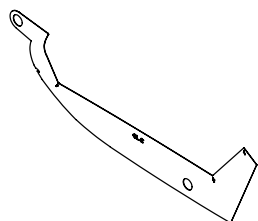

CUT TEMPLATE 2

QTY: 1

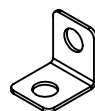

FENDER LINER BRACKETS

QTY: 4

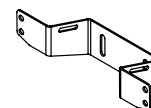

CENTER LIGHT BRACKETS

QTY: 2

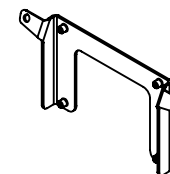

LICENSE PLATE BRACKET

QTY: 1

SKID PLATE PACKAGE CONTENTS

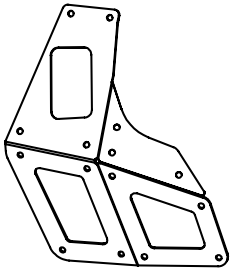

DRIVER KNUCKLE

QTY: 1

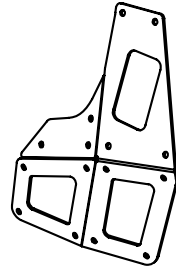

PASSENGER KNUCKLE

QTY: 1

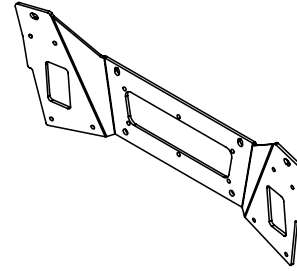

BUMPER SKID PLATE

QTY: 1

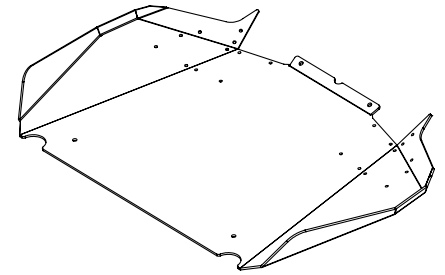

ENGINE SKID PLATE

QTY: 1

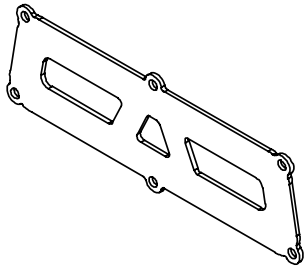

SKID PLATE VENT

QTY: 1

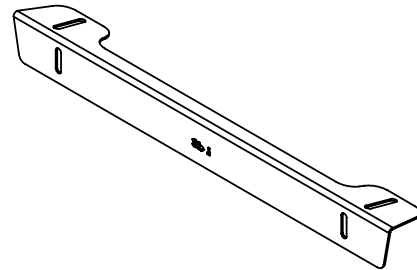

SKID PLATE BRACKET 1

QTY: 1

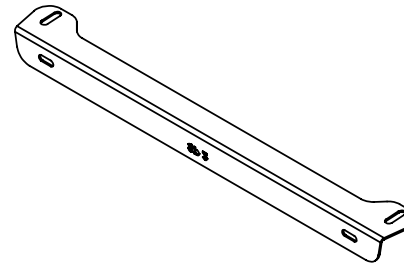

SKID PLATE BRACKET 2

QTY: 1

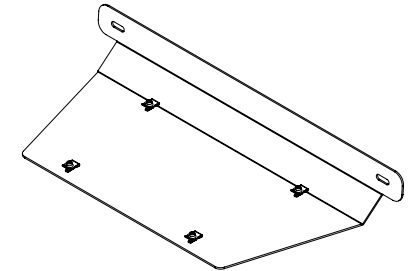

AWD SKID PLATE

QTY: 1

BULL BAR PACKAGE CONTENTS

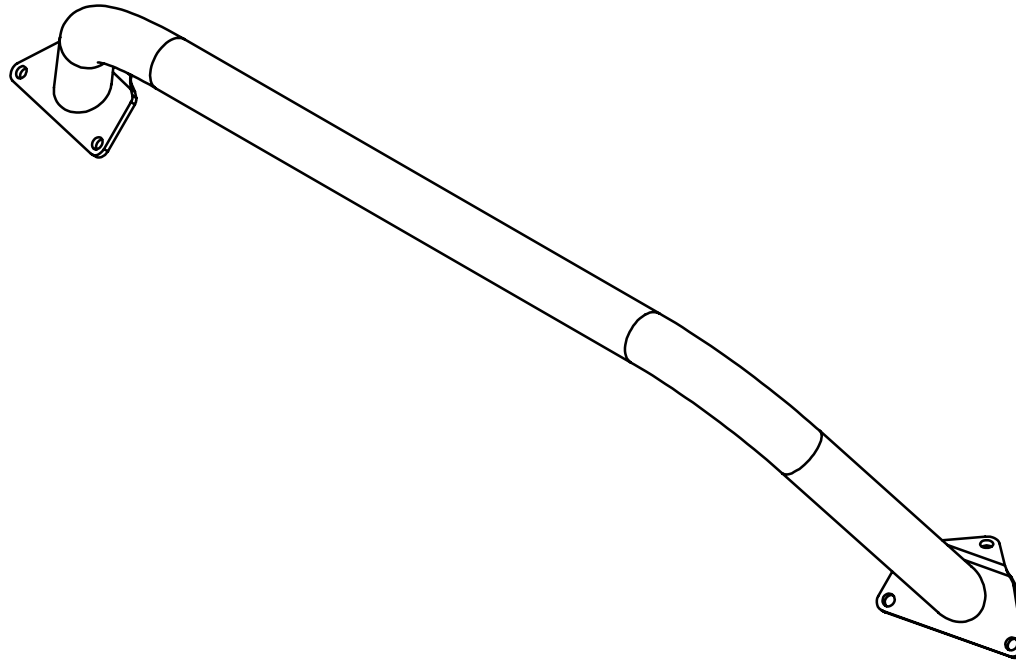

BULL BAR

QTY: 1

WINCH FAIRLEAD CONTENTS

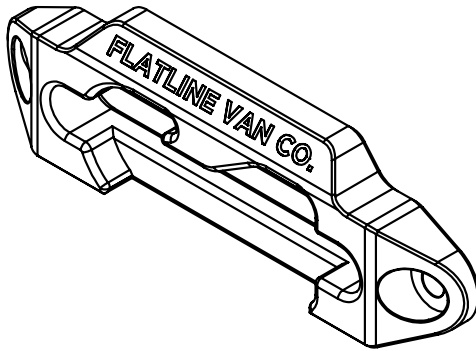

WINCH FAIRLEAD

QTY: 1

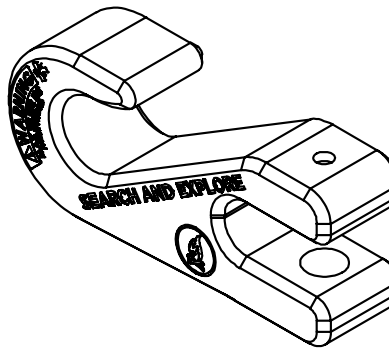

FAIRLEAD HOOK

QTY: 1

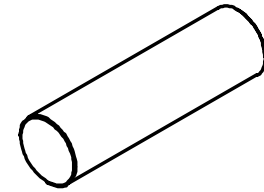

FAIRLEAD HOOK PIN

QTY: 1

BUMPER HARDWARE

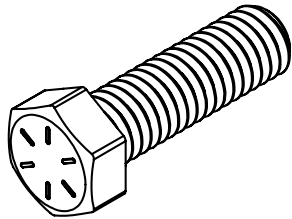

3/8-16 X 1.25 HEX BOLT

QTY: 8

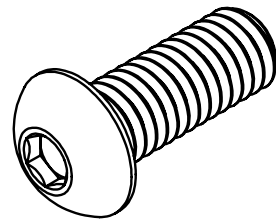

CUT TEMPLATE 2

QTY: 1

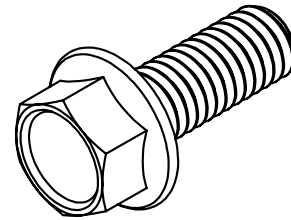

3/8-16 X 1 FLANGED HEX HEAD SCREW

QTY: 22

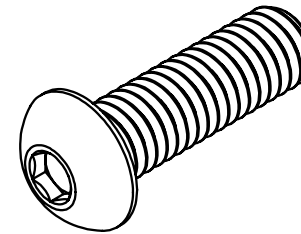

3/8-16 X 1 BUTTON HEAD HEX DRIVE SCREW

QTY: 2

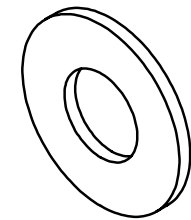

3/8 OVERSIZED FLAT WASHER

QTY: 8

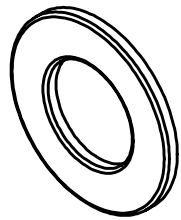

3/8 FLAT WASHER

QTY: 22

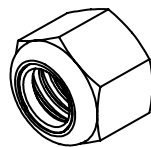

3/8-16 NYLON LOCKNUT

QTY: 22

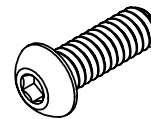

1/4-20 X 0.75 BUTTON HEAD HEX DRIVE SCREW

QTY: 12



1/4 SCREW FLAT WASHER

QTY: 4

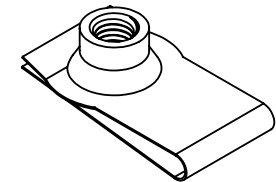

3/8-16 X 1.125 CLIP NUT

QTY: 8

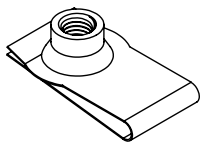

1/4-20 X 0.531 CLIP NUT

QTY: 8

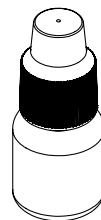

THREADLOCKER

QTY: 1

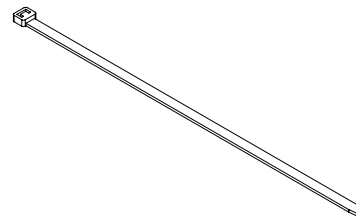

CABLE TIES

QTY: 25

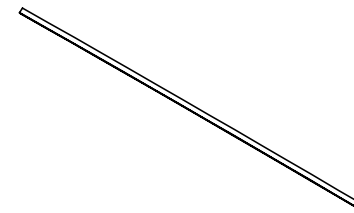

GASKET TRIM

QTY: 2

SKID PLATE HARDWARE

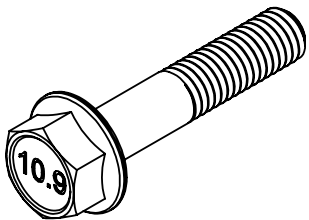

M8-1.25 X 40 FLANGED
HEX HEAD SCREW

QTY: 2

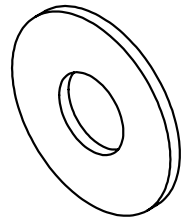

3/8-16 OVERSIZED FLAT
WASHER

QTY: 2

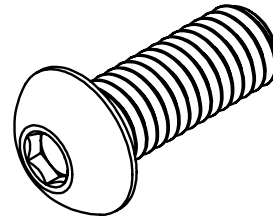

3/8-16 X 1 BUTTON HEAD
HEX HEAD SCREW

QTY: 6

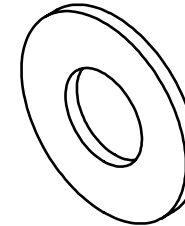

3/8-16 FLAT WASHER

QTY: 6

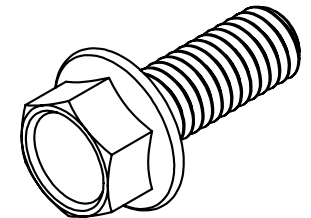

3/8-16 X 1 FLANGED HEX
HEAD SCREW

QTY: 2

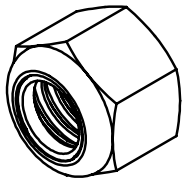

3/8-16 NYLON LOCKNUT

QTY: 6

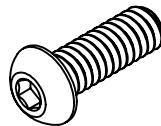

1/4-20 X 0.75 BUTTON
HEAD HEX DRIVE SCREW

QTY: 36

AWD +4

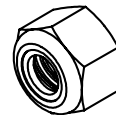

1/4-20 NYLON LOCKNUT

QTY: 36



1/4 SCREW FLAT WASHER

QTY: 36

AWD +4

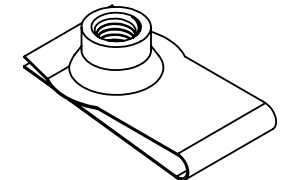

1/4-20 x 0.531 CLIP NUT

AWD +4

WINCH FAIRLEAD HARDWARE

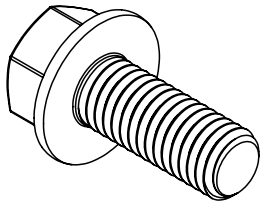

1/2-13 X 1.25 FLANGED HEX
HEAD SCREW

QTY: 2

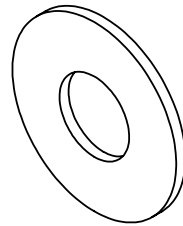

1/2" FLAT WASHER

QTY: 2

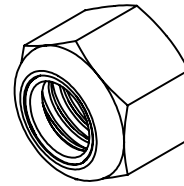

1/2-13 NYLON LOCKNUT

QTY: 2



0.625 RETAINING RING

QTY: 1

INSTALL

STEP | 01 LAYOUT & INSTALL PREP

1.1 Safety Check: Disconnect battery (both if applicable) prior to performing any electrical work and ensure you are working on a flat surface (FIG 1).

1.2 Review Install Outline: Thoroughly read all instructions and warnings before beginning installation. This product requires modifications to factory parts *done at your own risk*. If you don't feel comfortable installing this on your own, see our [Find a Builder or Upfitter](#) page to locate an approved installer near you. We also highly recommend watching the [Install Video](#) alongside the written instructions.

1.3 Bumper Accessories: If you plan on running a [Winch](#) or [Off-Road Lights](#) (FIG 2), waiting to install the [Bumper](#) until those parts are ready to install as well would be advised.

TOOLS REQUIRED FOR THIS STEP:



FIG 1

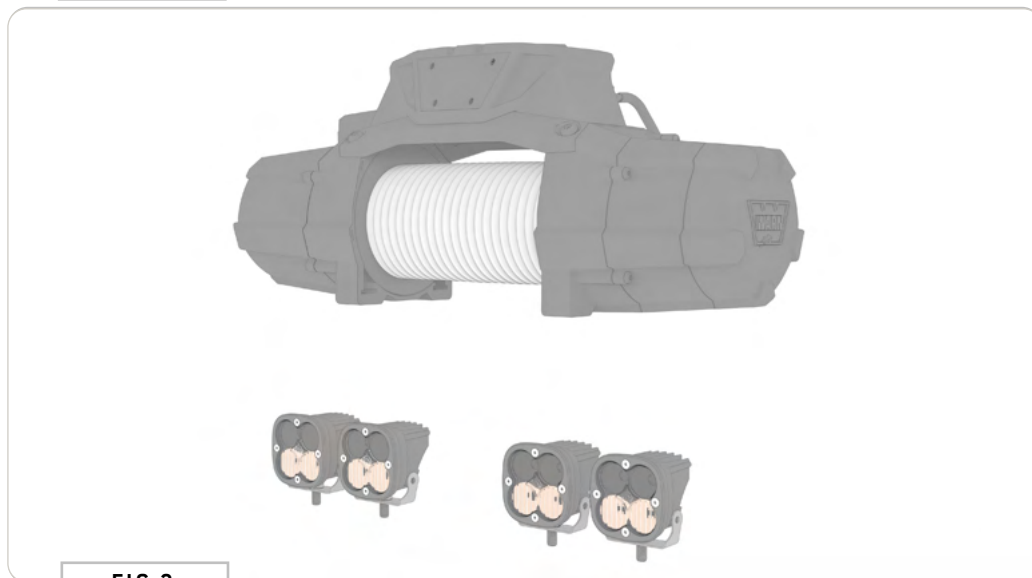

FIG 2

TOOLS REQUIRED FOR THIS STEP: + MASKING TAPE

STEP | 02 BUMPER COVER CUT LINES

2.1 Cut Line 1: Align **Cut Line Template 1** to body lines (**FIG 3**) and lay flat against the surface (**FIG 4**). Use **Masking Tape** to hold in place.

2.2 Cut Line 2: Align **Cut Line Template 2** sensor hole-to-sensor hole (**FIG 5**). Rotate to align with the body line and loosely tape into place while pressing the template flat against the surface (**FIG 6**).



FIG 3



FIG 4



FIG 5

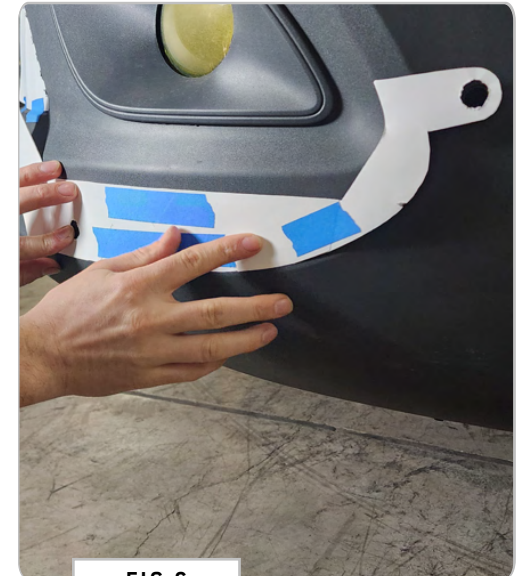
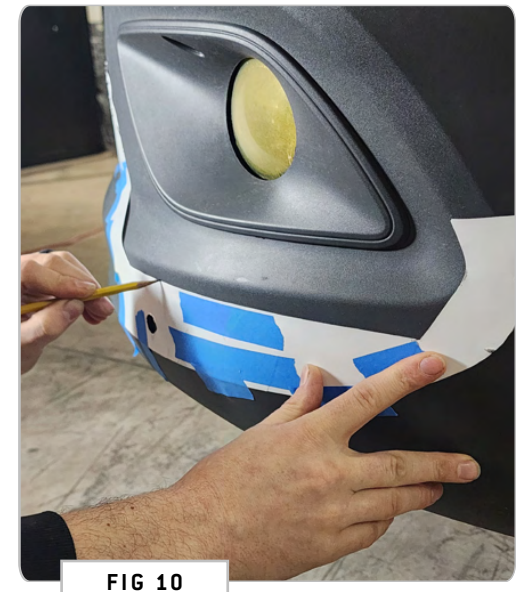
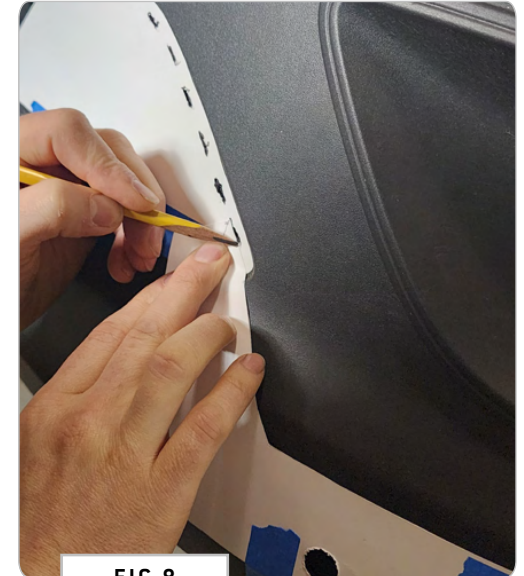

FIG 6

TOOLS REQUIRED FOR THIS STEP: + PENCIL

STEP | 02 BUMPER COVER CUT LINES

2.3 Tracing Cut Lines: Ensure **Cut Line Template 2** edge aligns with cut outline in **Cut Template 1** (FIG 7) and proceed to trace **Cut Lines** (FIG 8-10).



STEP | 02 BUMPER COVER CUT LINES

2.4 Cut Line 3: Measure and mark 12.5" down from the top of the **Plastic Bumper Skin (FIG 11)**. Tape from mark to **Cut Line 3 Notch (FIG 12+13)**. Trace **Cut Line 3 (FIG 14)**.

2.5 Finish Driver Side Cut Line: Carefully remove **Templates** and connect all gaps in **Cut Lines**.

2.6 Passenger Side Cut Line: Flip templates and repeat process on other side.

TOOLS REQUIRED FOR THIS STEP:

- + MEASURING TAPE
- + MASKING TAPE
- + PENCIL
- + MARKER

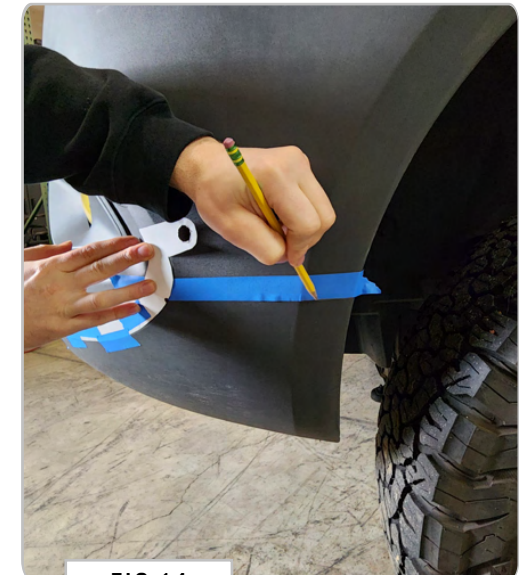

TOOLS REQUIRED FOR THIS STEP: + T25 TORX
 + T30 TORX
 + PRY TOOL

STEP | 03 BUMPER COVER REMOVAL

3.1 Remove Grill: Remove 3 screws on top of the grill with a T25 Torx. *Retain these screws for future steps.*

3.2 Bumper Cover Removal (Side): Remove fender well plastic rivets with a pry tool. There are four per side; one vertical along the top edge and three along the low side (FIG 16).

PRO-TIP: Use a pry tool to pop the center plastic rivet pin out first before prying from the bottom.

3.3 Bumper Cover Removal (Bottom): Remove bottom plastic rivets; two per each side (FIG 17).

3.4 Bumper Cover Removal (Front): Remove two screws hidden behind the grill with a T30 Torx (FIG 18).



FIG 15



FIG 16

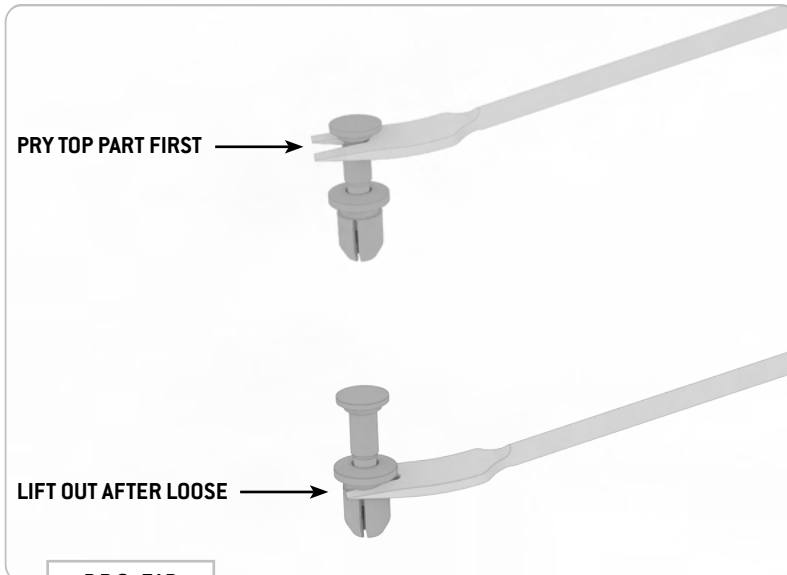

PRO-TIP



FIG 17



FIG 18

TOOLS REQUIRED FOR THIS STEP:

STEP | 03 BUMPER COVER REMOVAL

3.5 Release Bumper Cover (Sides): Pull outwards at the top corner of the fender well to release clips on both sides (FIG 19).

3.6 Release Bumper Cover (Front): Pull upwards around the center step area to help release the bumper (FIG 20). Once the bumper is free, leave it hanging in place (FIG 21+22) in order to release electrical components from the bumper housing (no need to disconnect wires).



FIG 19



FIG 20



FIG 21

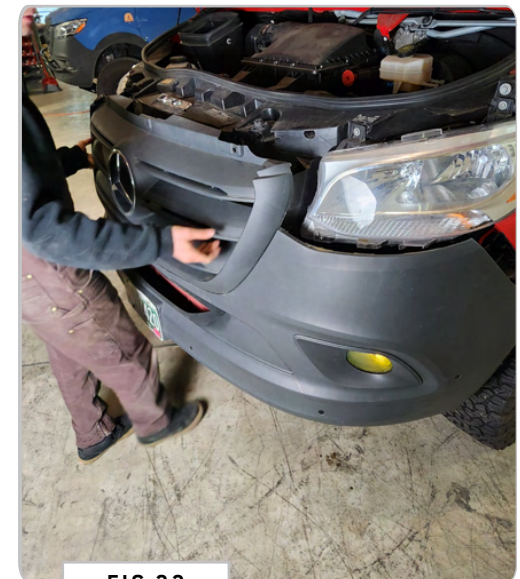

FIG 22

TOOLS REQUIRED FOR THIS STEP: + FLATHEAD SCREWDRIVER

STEP | 03 BUMPER COVER REMOVAL

3.7 Release Ambient Air Sensor: Remove Ambient Air Sensor from grill (FIG 23).

3.8 Release Fog Light Harnesses: Disconnect fog light harnesses before fully removing the Factory Bumper Skin. Squeeze tabs on both sides and pull downwards to release (FIG 24).

3.9 Release Park Sensor Harness: On Park Sensor Harness, use a small Flathead Screwdriver (FIG 25) to gently pry white clip outwards (do not remove), then push down on white clip and pull apart to release electrical connector (FIG 26).



FIG 23

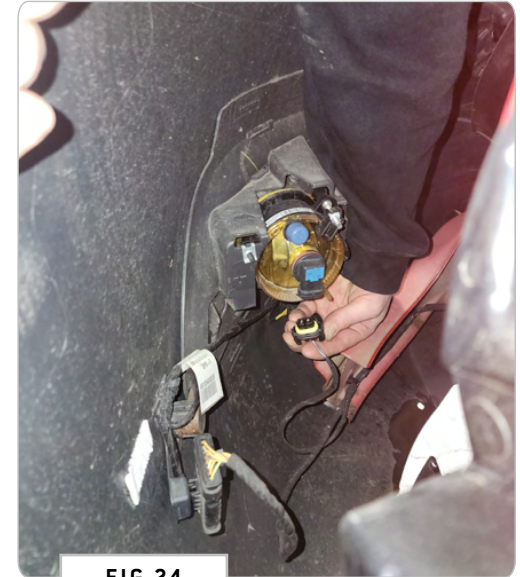

FIG 24



FIG 25

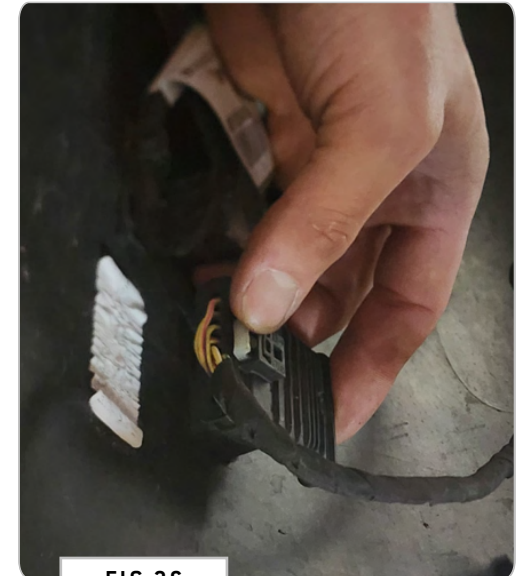

FIG 26

TOOLS REQUIRED FOR THIS STEP: + FLATHEAD SCREWDRIVER

STEP | 03 BUMPER COVER REMOVAL

3.10 Release Camera Bezel (if applicable): If you aren't able to disconnect the **Camera** from the **Camera Bezel**, use a small screwdriver to gently pry on the tabs of both sides of the **Camera Bezel** until it releases (**FIG 27+28**).

NOTE - Make sure to note which side of the camera is up when you remove it (**FIG 29**). You can mark the orientation with masking tape until it is ready to be reinstalled

3.11 Remove Bumper Cover: Fully remove factory bumper cover and set aside (**FIG 30**).



FIG 27



FIG 28

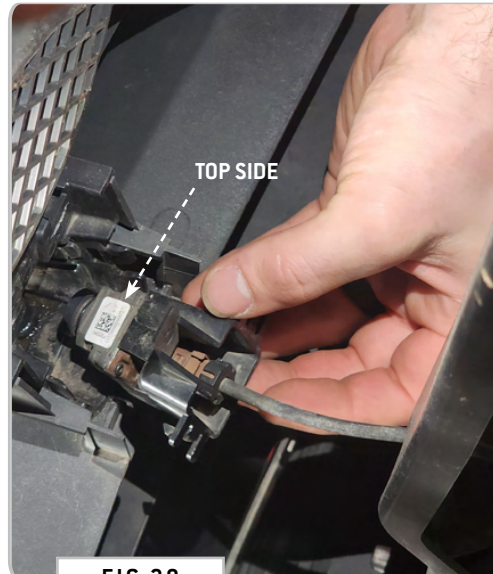

FIG 29

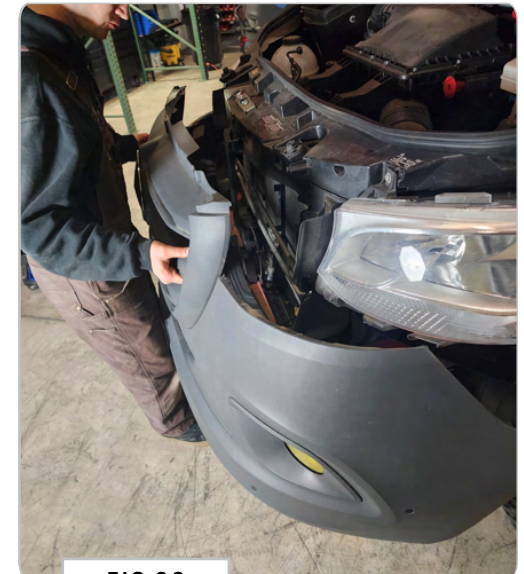

FIG 30

TOOLS REQUIRED FOR THIS STEP: + MASKING TAPE

STEP | 04 REMOVE INTERNALS

4.1 Identify Internals: See FIG 31 to identify components to be released in the following steps: **Camera, Cruise Control Radar Sensor, Center Support, Factory Bumper and Splash Guard.**

4.2 Disconnect Camera: Press tabs on **Camera Bezel (FIG 32)** to disconnect from the wiring harness (**FIG 33**). Pass wire back through center support and disconnect from the back (**FIG 34**).

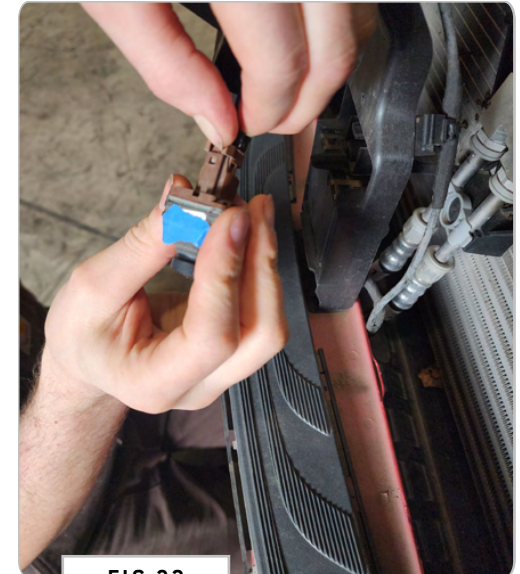

TOOLS REQUIRED FOR THIS STEP: + FLATHEAD SCREWDRIVER
+ T25 TORX

STEP | 04 REMOVE INTERNALS

4.3 Adaptive Radar Sensor: Use a small Flathead Screwdriver to gently pry the Adaptive Radar Sensor tab upwards (FIG 35). Push the sensor out of the center support from the back (FIG 36) and disconnect from the harness by pressing in tabs and pulling apart (FIG 37).

4.4 Center Support: Use a T25 Torx to remove the two bolts holding the Center Support in place (FIG 38). Pull up to remove Center Support and discard.



FIG 35



FIG 36



FIG 37

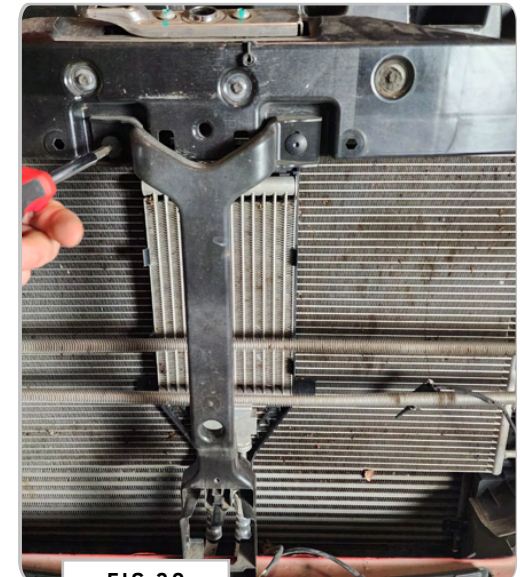

FIG 38

- TOOLS REQUIRED FOR THIS STEP:**
- + PRY TOOL
 - + 13MM SOCKET
 - + FLATHEAD SCREWDRIVER

STEP | 04 REMOVE INTERNALS

4.5 Removing Factory Bumper Wiring: Unclip wiring harnesses to free visible wires from the factory bumper (FIG 39).

4.6 Removing Factory Bumper: Use a 13mm Socket to remove the (8) M8 bolts securing the factory bumper in place (FIG 40). Carefully pull back the factory bumper to reveal the two central clips that hold the last of your wires in place (FIG 41). Unclip using a small flat screwdriver (FIG 42).

NOTE - Save bolts for installing the Winch Cradle in Step 6.



TOOLS REQUIRED FOR THIS STEP: + FLATHEAD SCREWDRIVER

STEP | 04 REMOVE INTERNALS

4.7 Remove Splash Guard: Use a small **Flathead Screwdriver** to gently pry the **Splash Guard (FIG 43)** out from the van using the two tabs on either side (**FIG 44**). You may discard this piece after removal (**FIG 45**).

NOTE - The components shown in **FIG 46** (**Factory Bumper, Center Support and Splash Guard**) can be discarded as they will not be needed after install of your new bumper.



FIG 43



FIG 44



FIG 45



FIG 46

STEP | 05 FVC BUMPER ASSEMBLY

5.1 Locate Bumper Components: The Bumper Assembly can be different depending on the configuration you ordered. See FIG 47 for how each component arrives shipped and FIG 48 for a diagram of how each of the pieces come together.

TOOLS REQUIRED FOR THIS STEP:



FIG 47

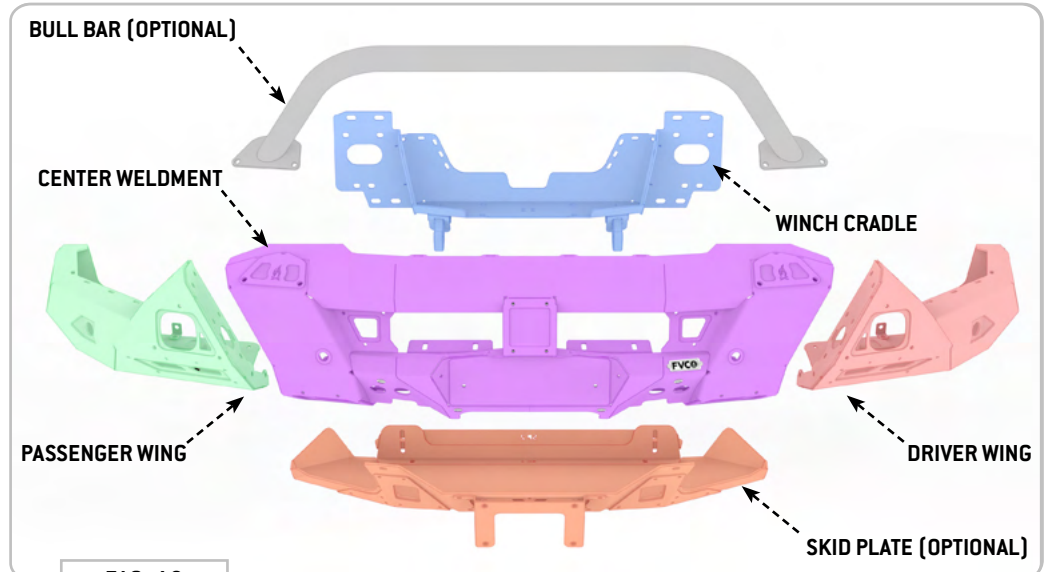

FIG 48

TOOLS REQUIRED FOR THIS STEP: + 9/16" WRENCH
+ 9/16" SOCKET

STEP | 05 FVC BUMPER ASSEMBLY

5.2 Driver Side Wing: Attach the **Driver Side Wing** to the **Center Weldment** using (7ea) **3/8-16 Flanged Hex Head Screws, Washers and Nylon Locknuts** in the locations shown in FIG 49+50.

5.3 Passenger Side Wing: Attach the **Passenger Side Wing** to the **Center Weldment** using (7ea) **3/8-16 Flanged Hex Head Screws, Washers and Nylon Locknuts** in the locations shown in FIG 51+52.

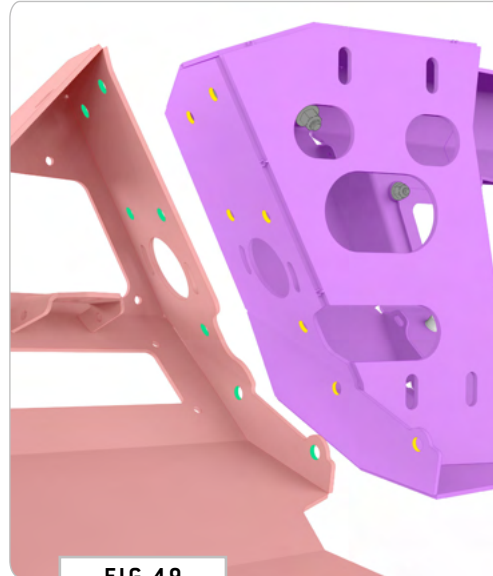

FIG 49

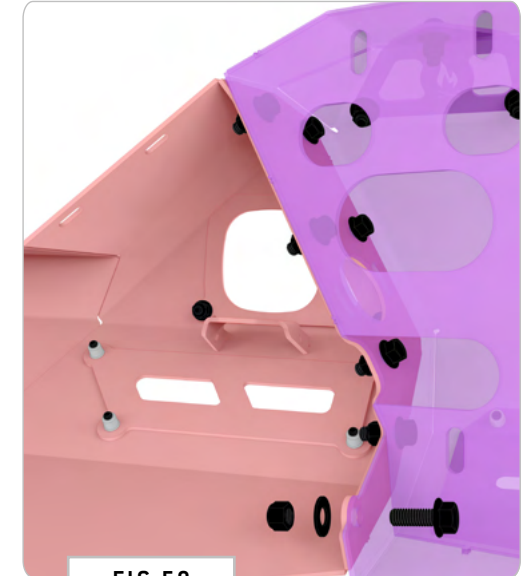

FIG 50

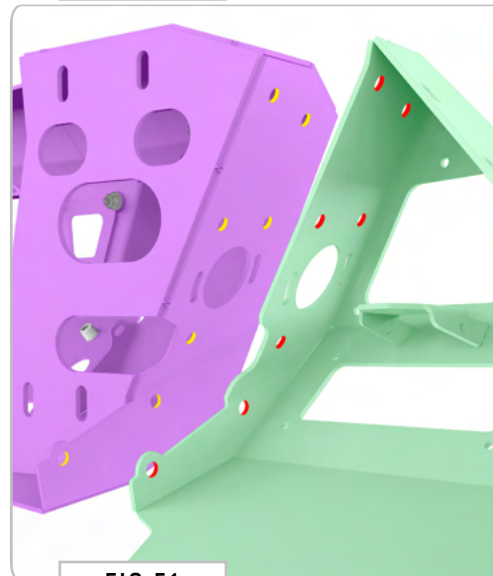

FIG 51

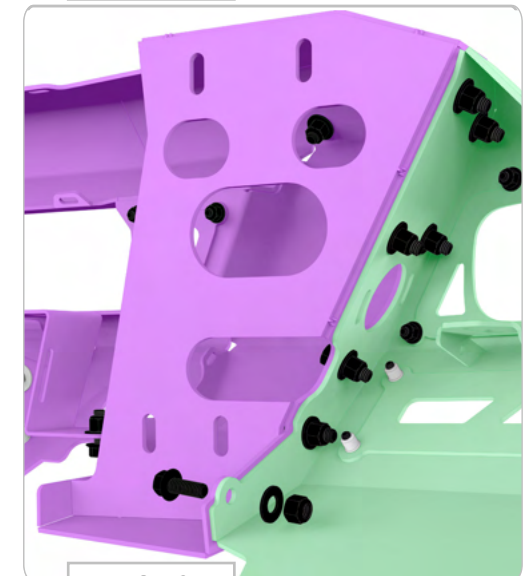

FIG 52

STEP | 05 FVC BUMPER ASSEMBLY

5.4 Install Bull Bar (Optional): If you ordered the **Bumper** with **Bull Bar**, you will attach it to the assembly at this time. Remove the plates covering the access points as shown in **FIG 53+54** and install the **Bull Bar** using the same hardware.

TOOLS REQUIRED FOR THIS STEP: + 7/32" ALLEN WRENCH
+ 9/16" WRENCH OR SOCKET

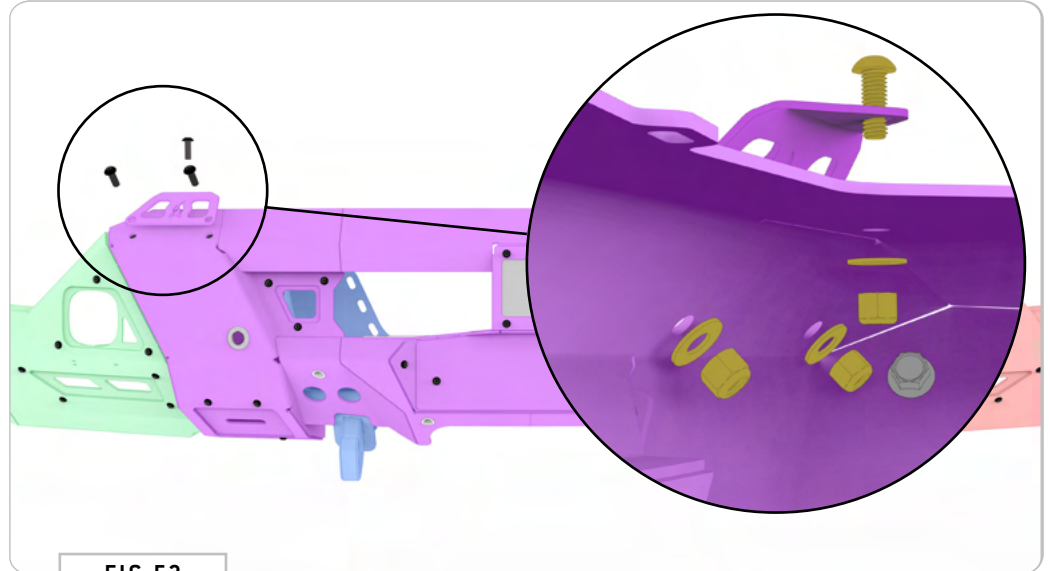

FIG 53

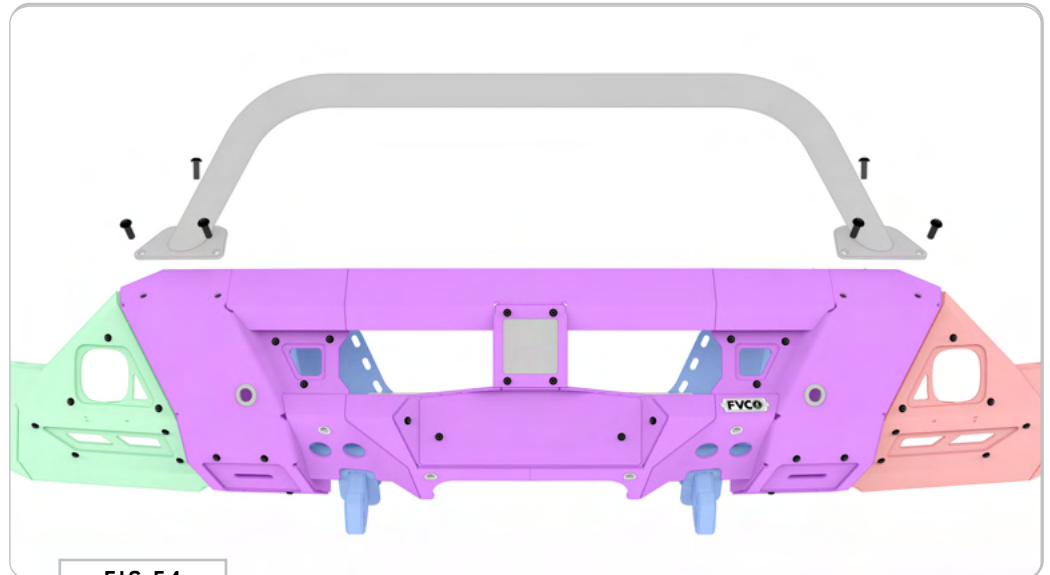

FIG 54

STEP | 05 FVC BUMPER ASSEMBLY

5.5 Install Winch Fairlead: Remove the 1/4-20 Hardware that hold the plate covering the **Winch Fairlead Mounting Holes** (FIG 55) and install Fairlead using (2) 1/2-13 x 1.25 Flanged Hex Head Bolts, Flat Washers and Nylon Locknuts as shown in FIG 56.1 and 56.2.

NOTE - It is recommended to install the Winch Fairlead on Bumper **before** the bumper has been installed to the van.

TOOLS REQUIRED FOR THIS STEP: + 5/32" ALLEN WRENCH
+ 7/16" WRENCH OR SOCKET
+ 3/4" WRENCH OR SOCKET

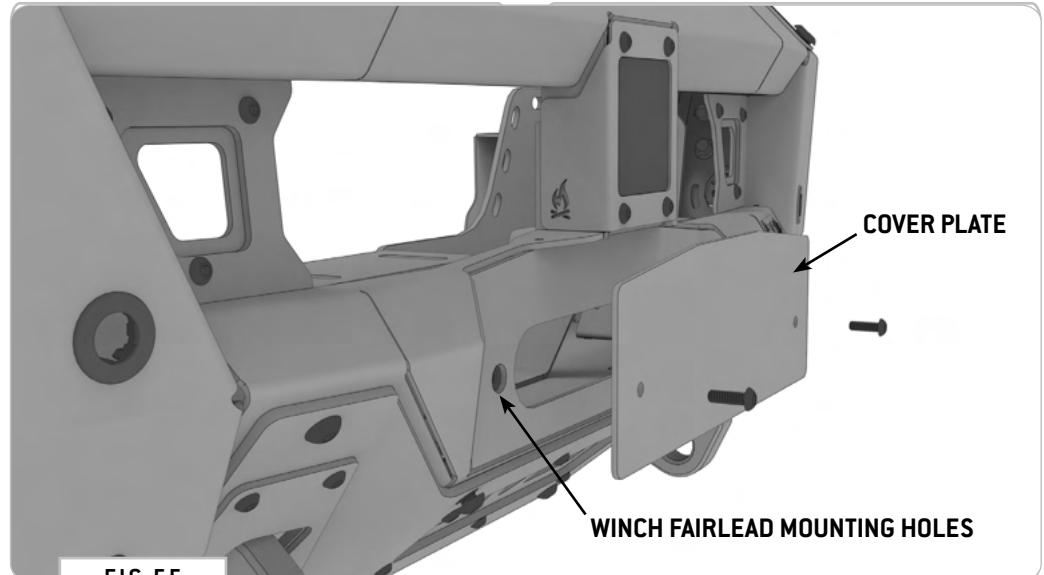

FIG 55

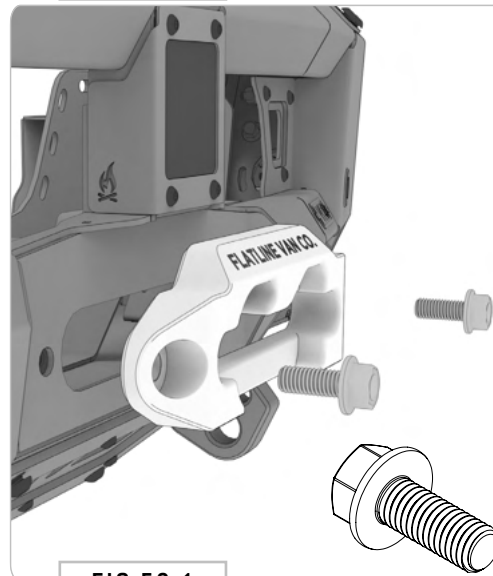

FIG 56.1

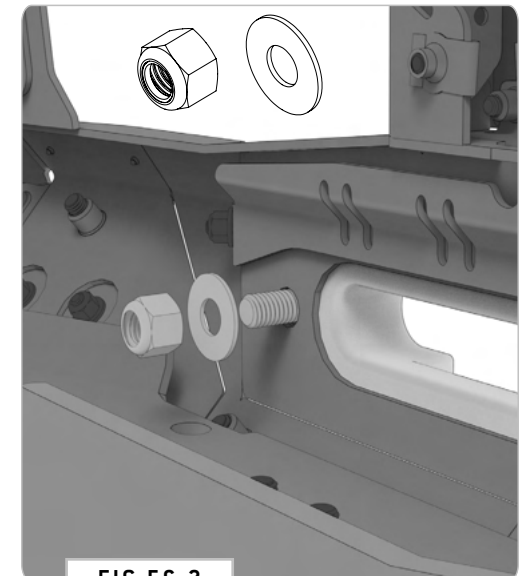

FIG 56.2

TOOLS REQUIRED FOR THIS STEP: + 13MM WRENCH OR SOCKET

STEP | 06 WINCH CRADLE INSTALL

6.1 Install Winch Cradle: Attach the **Winch Cradle** to the van's frame by using factory hardware with **Loctite** from the locations shown in **FIG 57**. Attach your **Clip Nuts** in the locations shown at this time. The **Barrel** of the **Clip Nut** should be on the backside of the **Winch Cradle** (**FIG 58**).

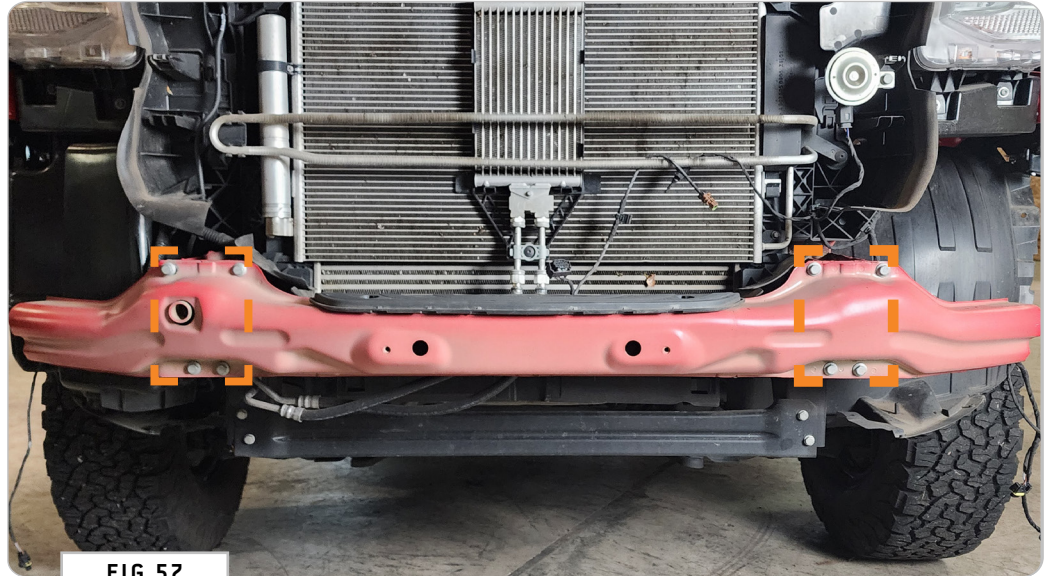

FIG 57

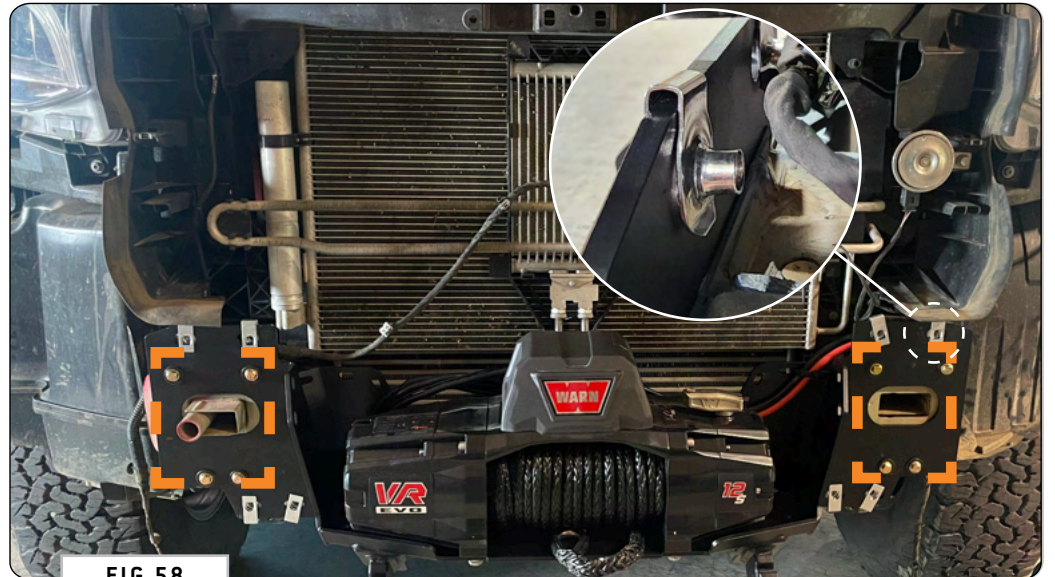

FIG 58

TOOLS REQUIRED FOR THIS STEP:

STEP | 06 WINCH CRADLE INSTALL

6.2 Install Winch: If running a **Winch**, attach the **Winch** to the **Winch Cradle** using the hardware provided with the **Winch** into the locations shown in **FIG 59+60**.

NOTE - The **Winch Cradle** fits winches up to **24.25" L x 7.15" D x 10.52" H** with a **10" x 4.5" bolt pattern**. We like the **Warn VR Evo 12-S** or **Zeon 12-S Platinum winch**.

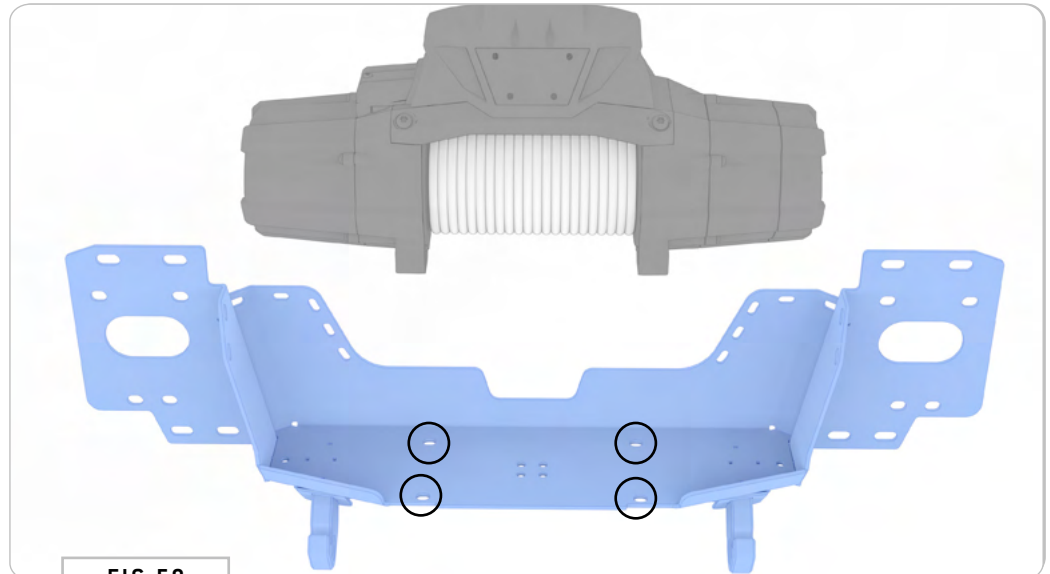

FIG 59

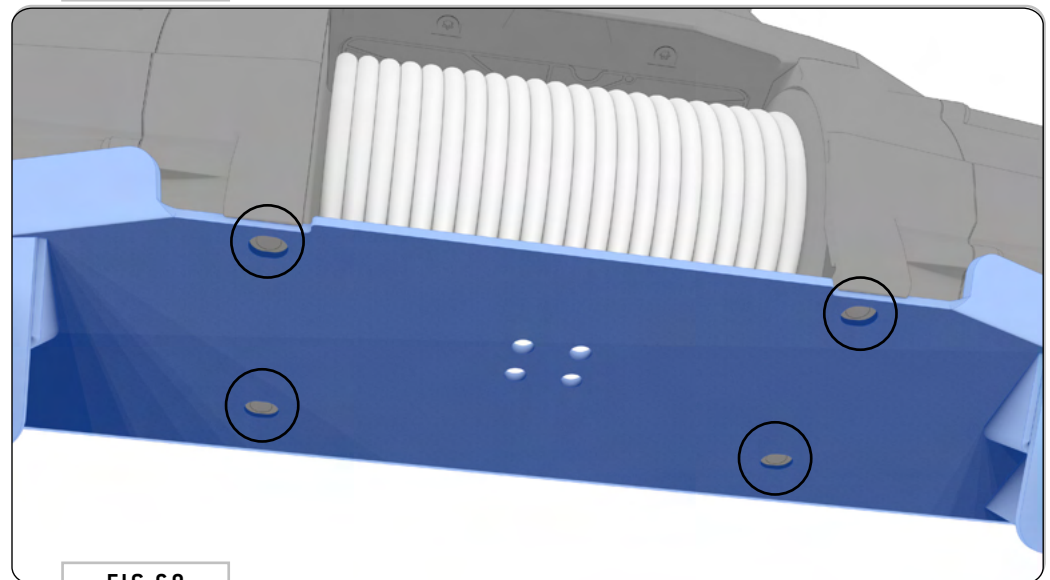

FIG 60

TOOLS REQUIRED FOR THIS STEP: + 9/16" WRENCH OR SOCKET

STEP | 06 WINCH CRADLE INSTALL

6.3 Install Center Light Brackets: If running Off-Road Lights, attach the Center Light Brackets to the Winch Cradle using (8) 3/8-16 Flanged Hex Head Screws, Washers and Nylon Locknuts into the locations shown in FIG 61+62.

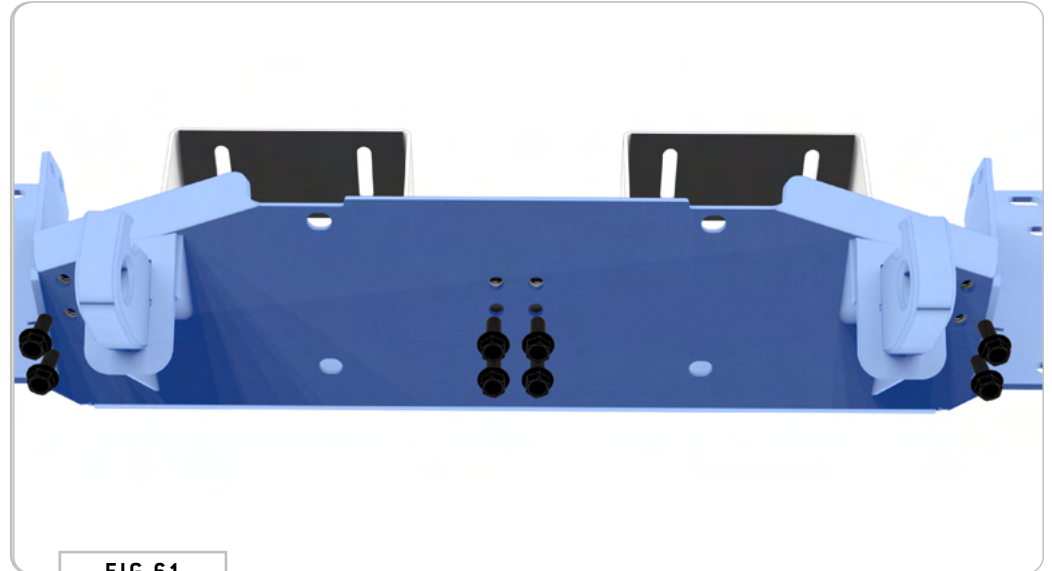

FIG 61

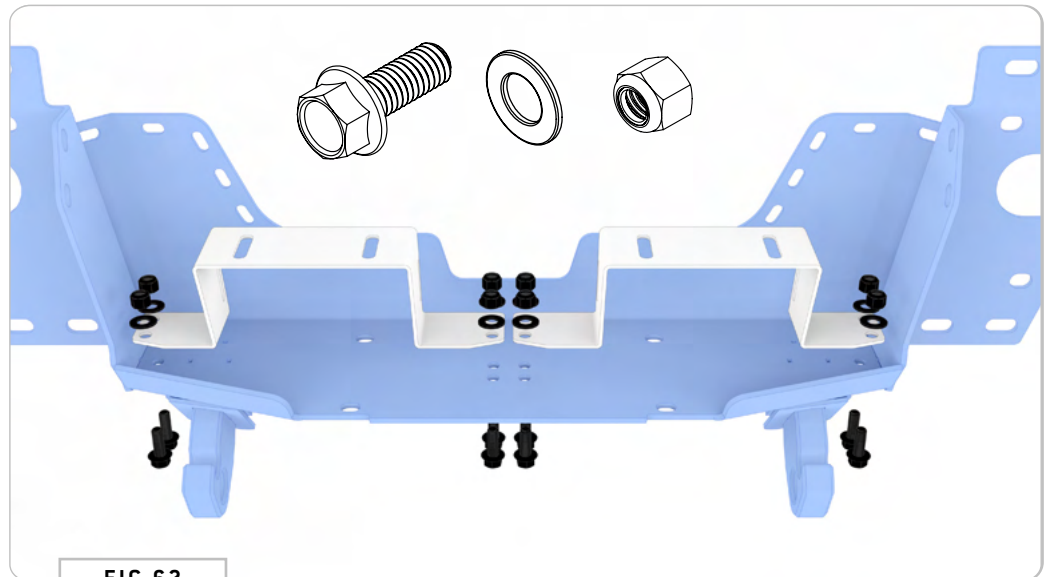
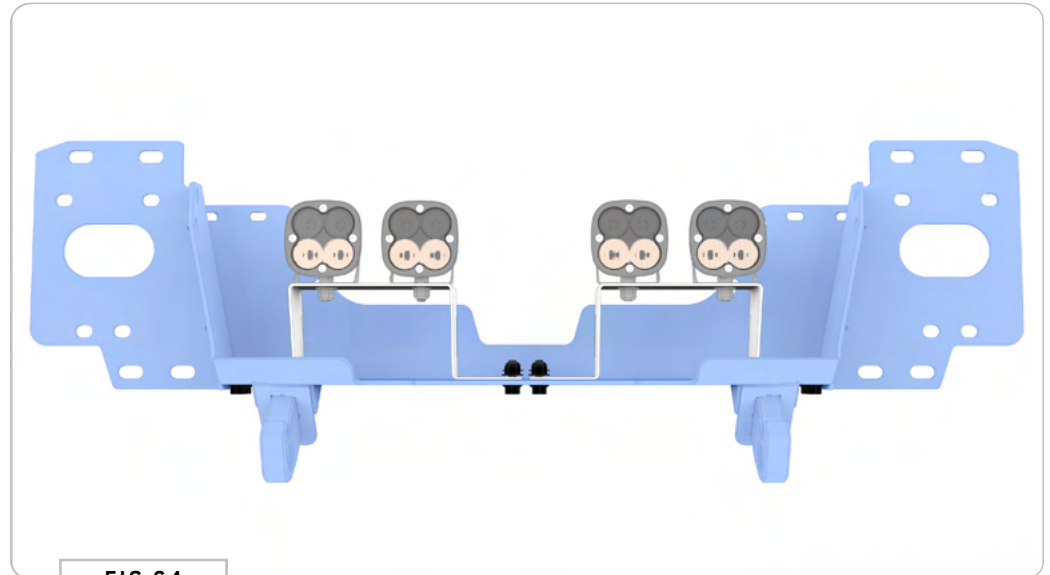
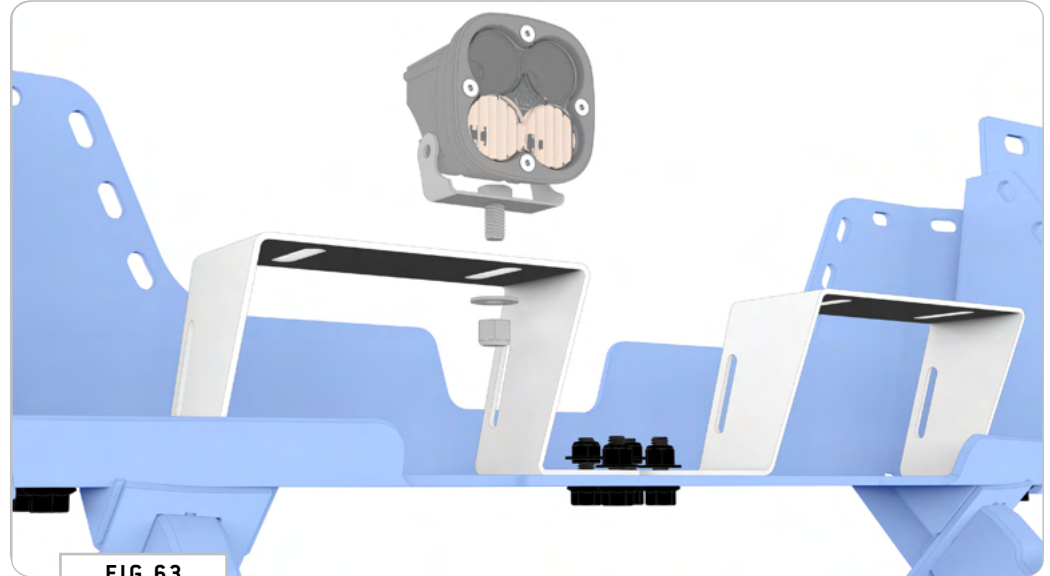

FIG 62

TOOLS REQUIRED FOR THIS STEP:

STEP | 06 WINCH CRADLE INSTALL

6.4 Install Center Lights: If running **Off-Road Lights**, attach the **Center Lights** to the **Center Light Brackets** using the hardware provided with the lights in the locations shown in **FIG 63+64**.



TOOLS REQUIRED FOR THIS STEP: + FLATHEAD SCREWDRIVER

STEP | 07 MIGRATING WIRING HARNESES

7.1 Disconnect Park Sensor Harness: Gently pry open the **Park Sensor Bezel (FIG 65)** that houses the **Park Sensor** to remove it from the **Factory Bumper Skin (FIG 66)**. See **FIG 67** for locations.

NOTE - Make sure to take note of what direction each of the park sensors are facing when you remove them as they will need to be reinstalled in the same configuration to the new Bumper. You could even mark the back of the sensor with a marker to notate its direction.



FIG 65



FIG 66

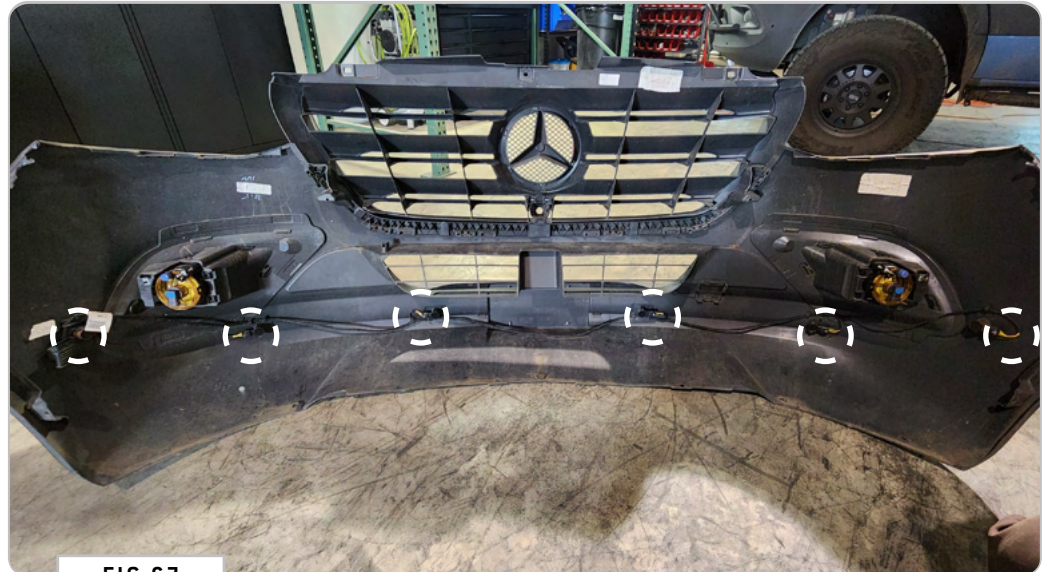

FIG 67

STEP | 07 MIGRATING WIRING HARNESES

7.2 Install New Park Sensor Bezels: See FIG 68 for new Park Sensor Bezel locations. Install by aligning the notches in the Park Sensor Bezel to the cutouts in the Bumper.

NOTE - The orientation of the **Bezel** corresponds to the direction in which the **Park Sensor** will be installed. See FIG 69+70 to observe how the molding of the **Park Sensor** aligns to the cutouts in the **Bezel**.

TOOLS REQUIRED FOR THIS STEP:

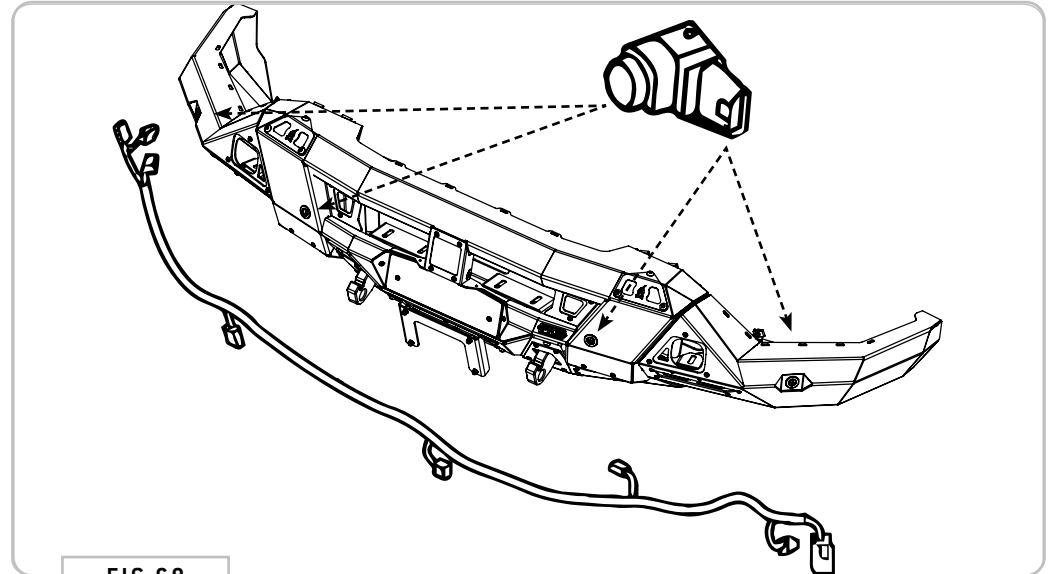

FIG 68

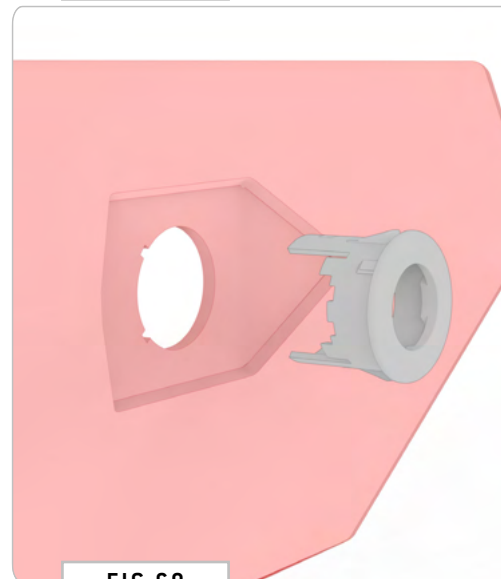

FIG 69

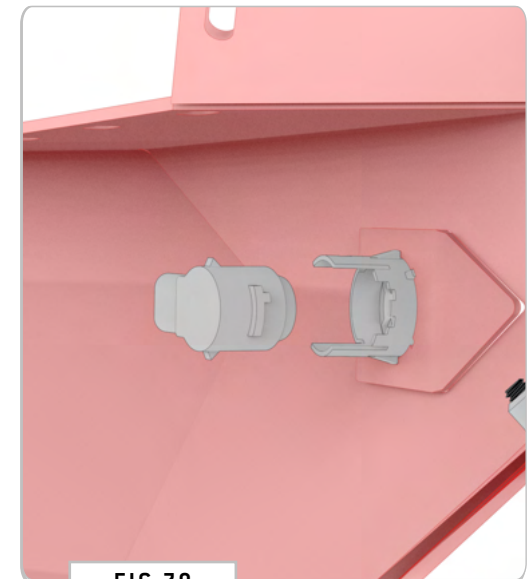

FIG 70

STEP | 07 MIGRATING WIRING HARNESES

7.3 Relocate Park Sensor Harness to FVC Bumper: Set the **Park Sensor Harness** alongside the assembled **Front Bumper**, and fish the harness through the **Driver's Side Access Hole** shown in **FIG 72**. Loosely secure using the supplied **Cable Ties** in the available slots (**FIG 73**).

TOOLS REQUIRED FOR THIS STEP:

RUN WIRING FOR LIGHTS UP HERE (IF APPLICABLE)

YOU MAY NEED TO LOOSEN THIS TO CLEAR HARNESS

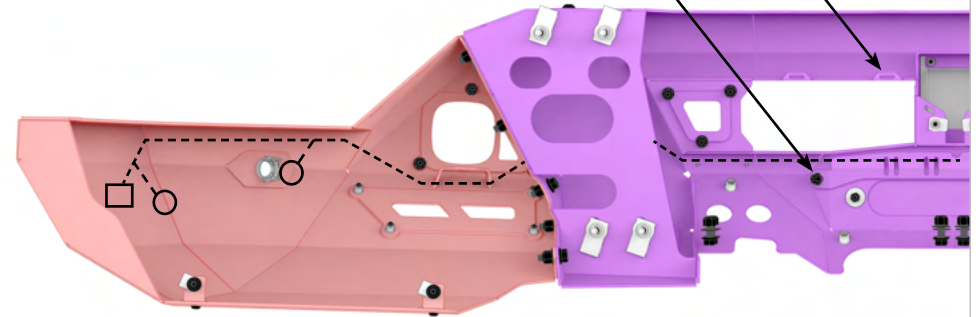

FIG 71



ACCESS HOLE

FIG 72

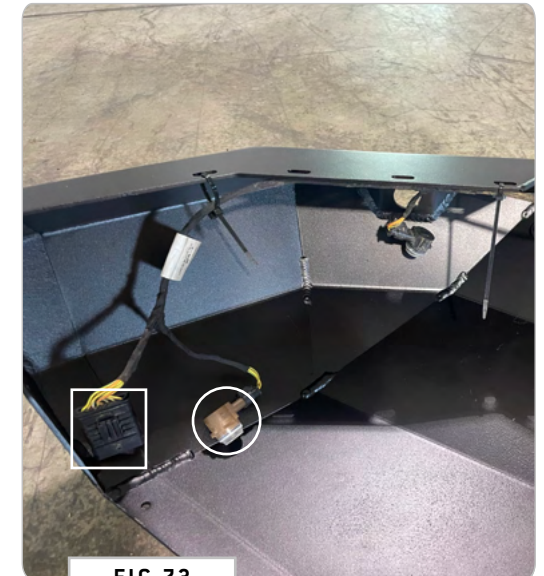
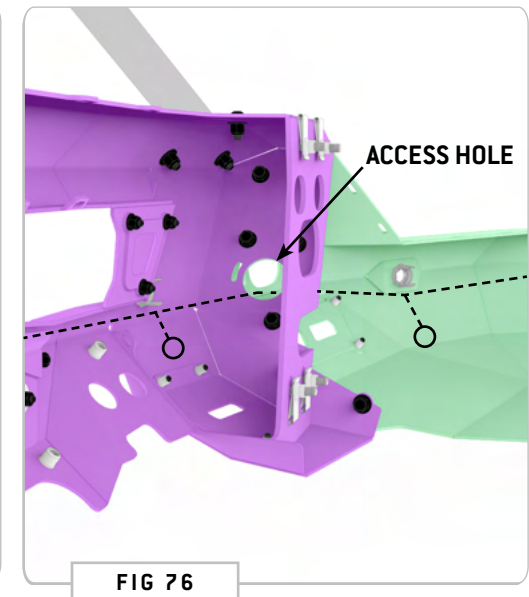
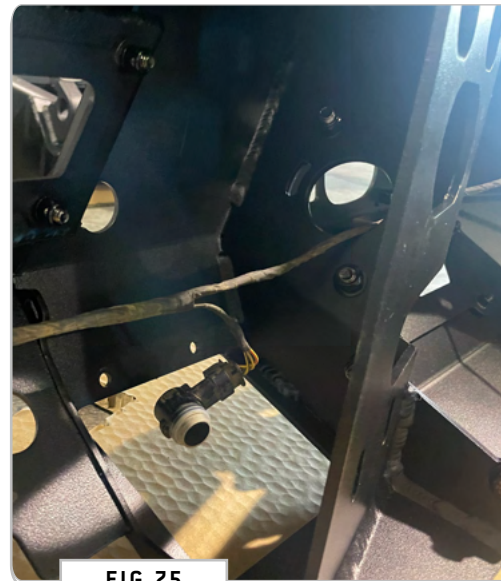
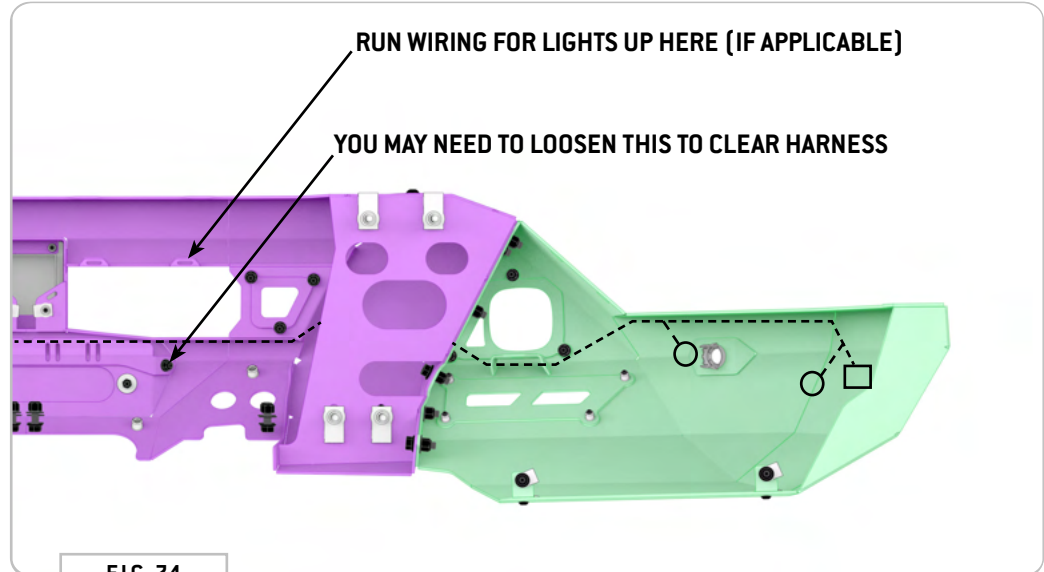

FIG 73

TOOLS REQUIRED FOR THIS STEP:

STEP | 07 MIGRATING WIRING HARNESES

7.4 Relocate Park Sensor Harness to FVC Bumper: Repeat the process from Step 7.3 for the **Passenger Side** and fish the harness through the access hole shown in **FIG 75+76**. Loosely secure using the supplied **Cable Ties** in the available slots.



TOOLS REQUIRED FOR THIS STEP:

STEP | 07 MIGRATING WIRING HARNESSES

7.5 Install Off-Road Lights (optional): If you have additional **Off-Road Lights** to install, do so at this time and consolidate your wiring before attaching the assembled **FVC Bumper** to your **Van**. See **FIG 77** for the location of the **Off-Road Light Bracket** within the **Wing** of the **Bumper Assembly**.

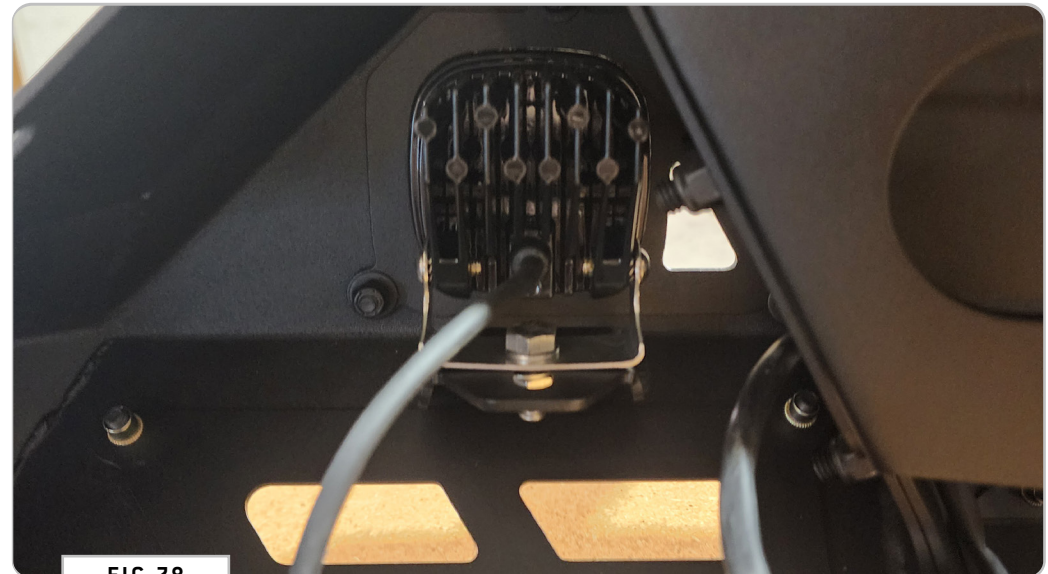
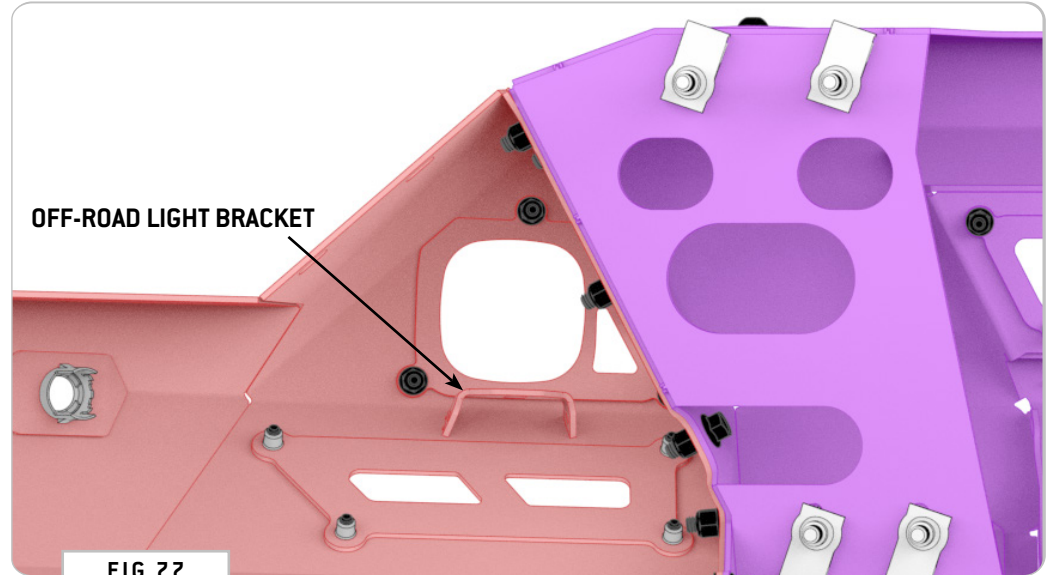

TOOLS REQUIRED FOR THIS STEP: + BODY SAW OR CUTOFF WHEEL

STEP | 08 CUTTING FACTORY BUMPER

8.1 Cutting Factory Bumper: Place your **Factory Bumper Cover** on the ground or set of saw horses (**FIG 79**) and begin to make your cuts along the marked cut lines using a body saw or cutoff wheel (**FIG 80+81**).

NOTE - *This cut doesn't have to be perfect! Just take your time and do your best. It will be covered by a **Rubber Gasket Trim** by the end of the install.*



FIG 79



FIG 80



FIG 81

TOOLS REQUIRED FOR THIS STEP: + BODY SAW OR CUTOFF WHEEL

STEP | 08 CUTTING FACTORY BUMPER

8.2 Cutting Factory Bumper: When you reach the middle section, use a marker to extend the cut line and maintain the arc as you reach the center (**FIG 82**). Proceed to make your cut along the edge through to the other side (**FIG 83+84**).

NOTE - *If necessary, smooth out this cut with a die grinder or 120 grit sanding disc.*



FIG 82



FIG 83



FIG 84

TOOLS REQUIRED FOR THIS STEP: + BODY SAW OR CUTOFF WHEEL

STEP | 08 CUTTING FACTORY BUMPER

8.3 Cutting Front Fender Liners: Using a **Body Saw**, cut off the protruding edge of the front **Fender Liners** as shown in **FIG 85-87**. You'll be attaching the front face of the **Fender Liner** to the **Bumper** using the **Fender Liner Brackets** in later steps.



FIG 85



FIG 86

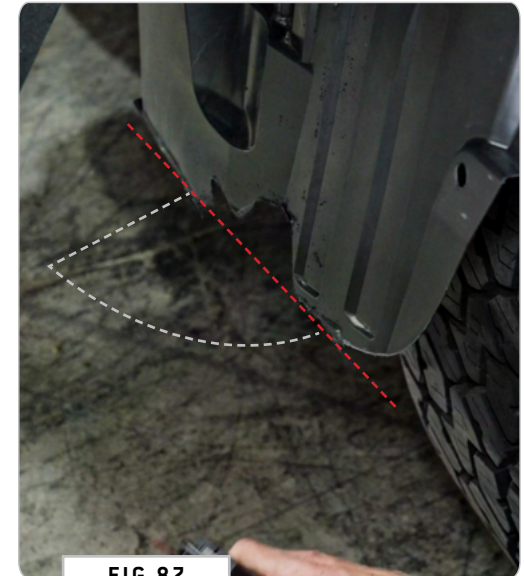

FIG 87

TOOLS REQUIRED FOR THIS STEP: + 9/16" WRENCH OR SOCKET

STEP | 09 INSTALL FVC BUMPER

9.1 Install FVC Bumper: To attach the FVC Front Bumper Assembly to the Winch Cradle, remove the **Access Covers (FIG 88)** and insert **(4) 3/8-16 x 1.25 Hex Head Bolts with Washers and Loctite** through the **Center Weldment** and into the **Clip Nuts** on the **Winch Cradle (FIG 89)**.

NOTE - A second set of hands will make this much easier.

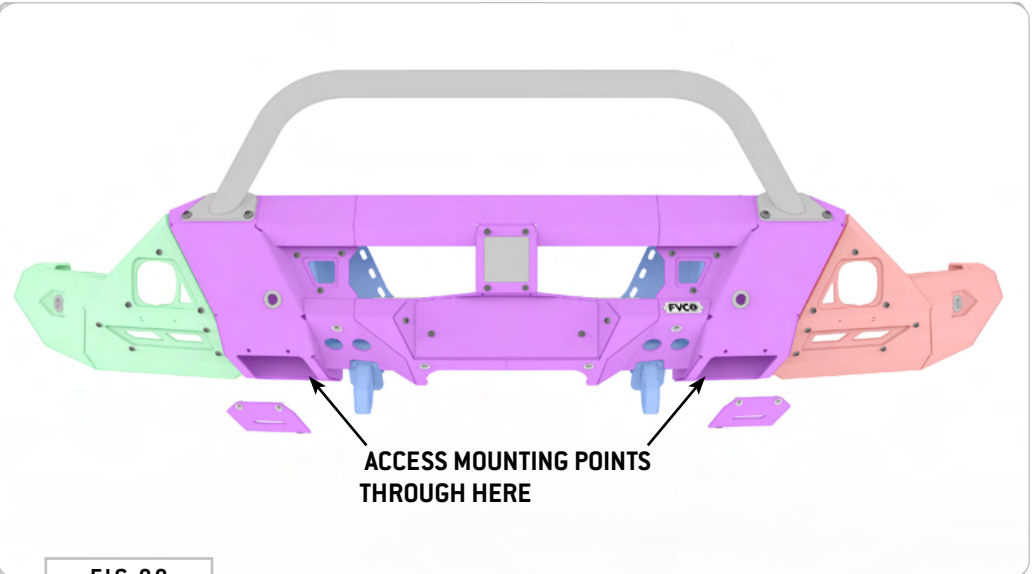

FIG 88

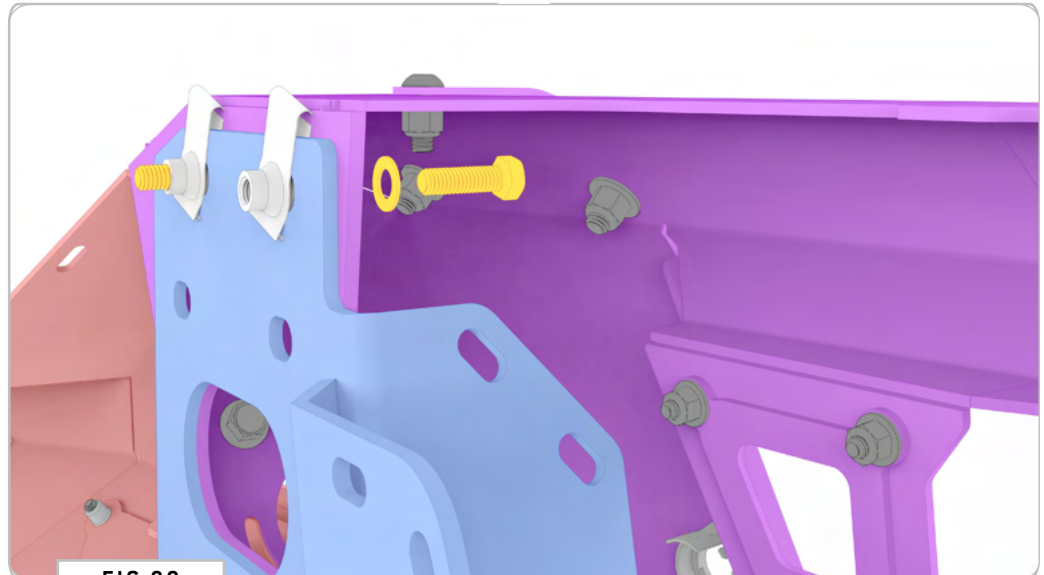
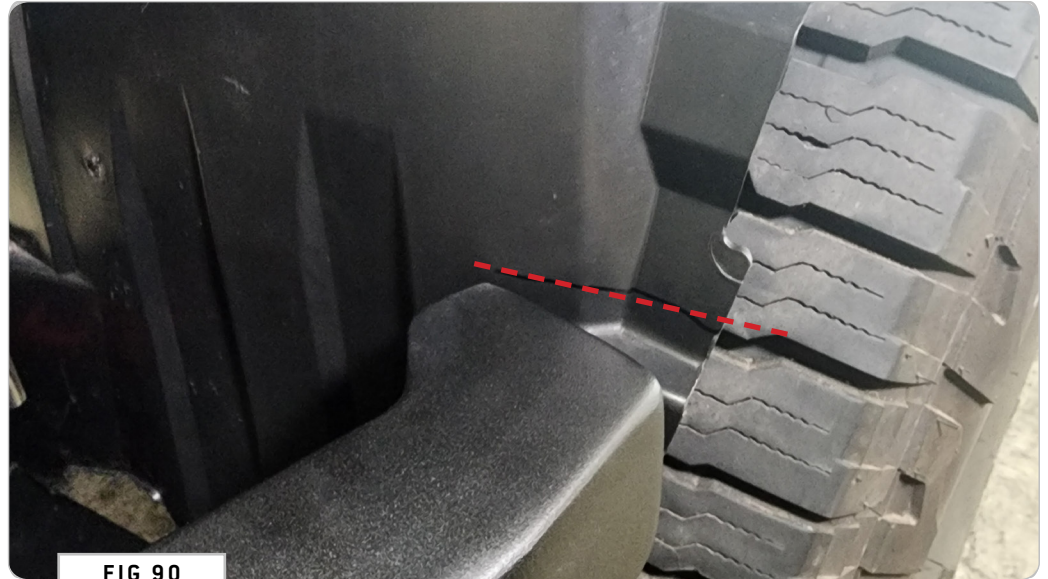

FIG 89

TOOLS REQUIRED FOR THIS STEP: + BODY SAW OR CUTOFF WHEEL

STEP | 09 INSTALL FVC BUMPER

9.2 Trim Fender Liners: Trim the **Fender Liners** so that they are able to be tucked inside the flanged edge of the **Bumper Wings** (FIG 90+91).



STEP | 09 INSTALL FVC BUMPER

9.3 Install Fender Liner Bracket to FVC Bumper: Loosely install the **Fender Liner Brackets** to the **Bumper** in the locations shown in **FIG 91** using 1/4-20 Clip Nuts and Screws.

9.4 Drill Out Fender Liner: Use the **Fender Liner Bracket** to mark the drill location and drill out using a 7/32" Drill Bit (**FIG 93**).

9.5 Install Fender Liner Bracket to Fender Liner: Attach another 1/4-20 Clip Nut to the **Fender Liner Bracket** and secure using a 1/4-20 x 0.75" Button Head Screw (**FIG 94**).

TOOLS REQUIRED FOR THIS STEP: + 5/32" ALLEN WRENCH
+ POWER DRILL
+ 7/32" DRILL BIT

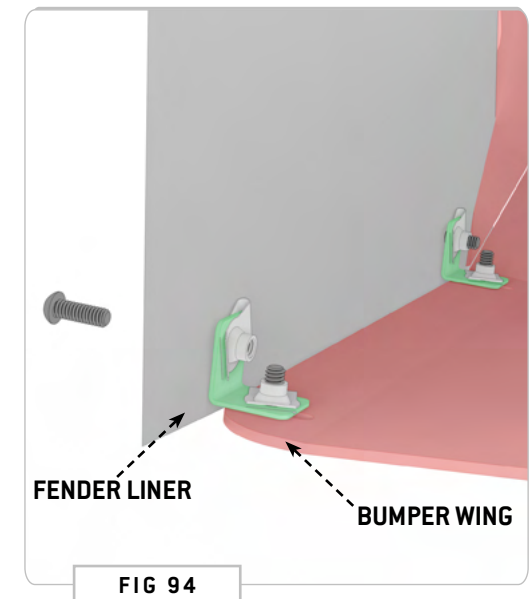
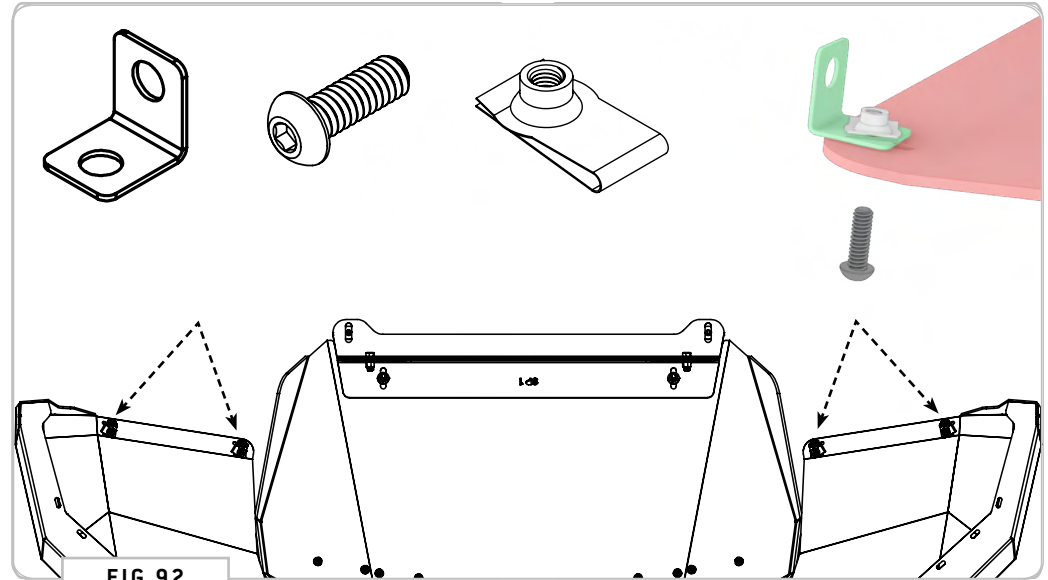

STEP | 10 SKID PLATE ASSEMBLY

10.1 Skid Plate Assembly: Find the components shown in FIG 95 and lay them down on a flat, non-abrasive surface for assembly.

10.2 Skid Plate Vent: Attach the Skid Plate Vent to the Bumper Skid Plate using (6ea) 1/4-20 x 1.5 Button Head Hex Drive Screws, 1/4" Flat Washers and Nylon Locknuts (FIG 96).

10.3 Engine Skid Plate: Loosely attach the Engine Skid Plate to the Bumper Skid Plate using (2ea) 3/8-16 x 1 Button Head Hex Drive Screws, 3/8" Flat Washers and Nylon Locknuts (FIG 96).

10.4 Side Knuckles: Loosely attach the Side Knuckles to the Bumper and Engine Skid Plates using (15ea) 1/4-20 x 1.5 Button Head Hex Drive Screws, 1/4" Flat Washers and Nylon Locknuts (FIG 97).

10.5 License Plate Bracket (Optional): If you would like to run a license plate, attach the License Plate Bracket to the Bumper Skid Plate at this time using (2ea) 3/8-16 x 1 Button Head Hex Drive Screws, 3/8" Flat Washers and Nylon Locknuts.

10.6 Tighten Fasteners: Go through and tighten this assembly together before proceeding to the Skid Plate Brackets.

10.7 Skid Plate Bracket 1: Loosely attach Skid Plate Bracket 1 using (2ea) 3/8-16 x 1 Button Head Hex Drive Screws, 3/8" Flat Washers and Nylon Locknuts (FIG 95).

TOOLS REQUIRED FOR THIS STEP: + 7/32" ALLEN WRENCH
+ 5/32" ALLEN WRENCH
+ 9/16" WRENCH OR SOCKET
+ 7/16" WRENCH OR SOCKET

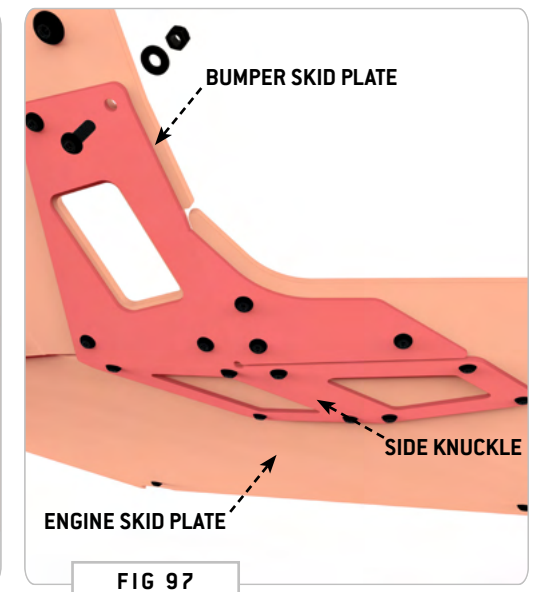
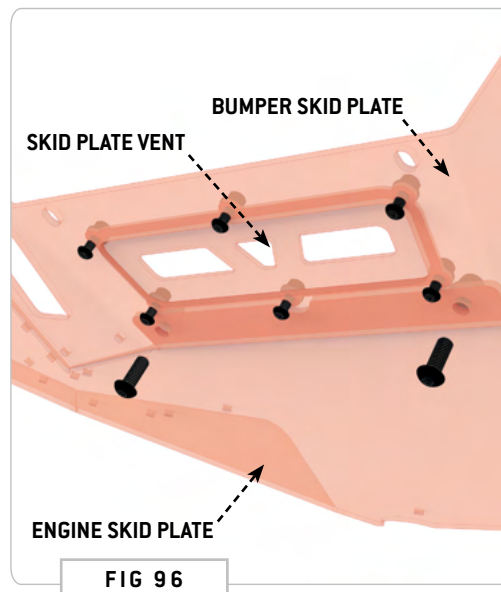
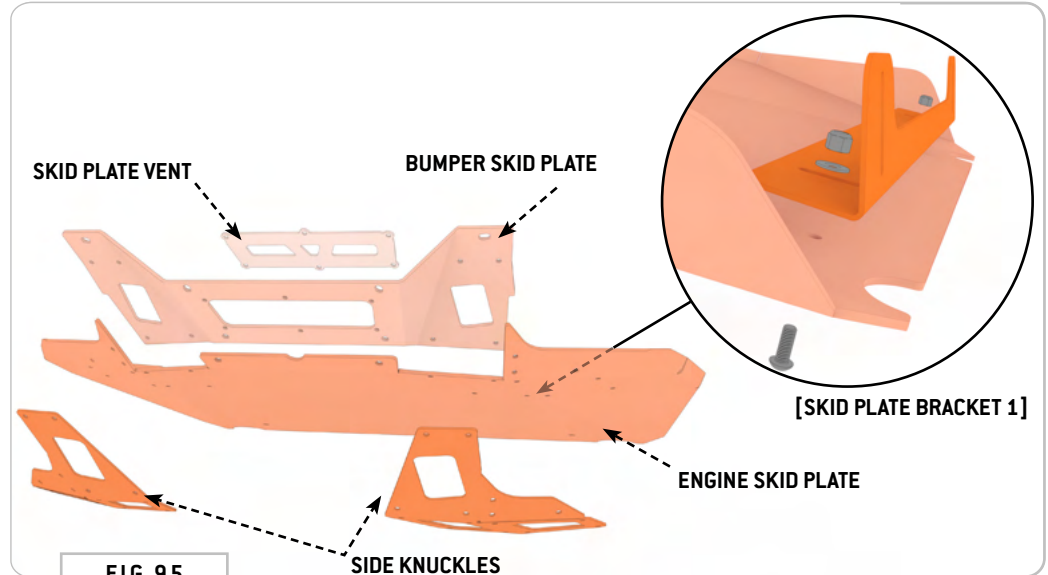

TOOLS REQUIRED FOR THIS STEP: + 7/32" ALLEN WRENCH
+ 9/16" WRENCH OR SOCKET

[SKIP THIS PAGE IF 2023+ AWD]

STEP | 10 SKID PLATE ASSEMBLY

10.8 Skid Plate Bracket 2: Loosely attach Skid Plate Bracket 2 using (2ea) 3/8-16 x 1 Hex Drive Screws, 3/8" Flat Washers and Nylon Locknuts (FIG 98A).

10.9 Locate Van Mounts (4WD Vans): There are slots of adjustment built in to Skid Plates 1 and 2 that will make alignment to the van's mounting points easier. See FIG 99A for locations of the threaded mounts that the Skid Plate will be attached to. Remove the bolts threaded into these mounts and discard.

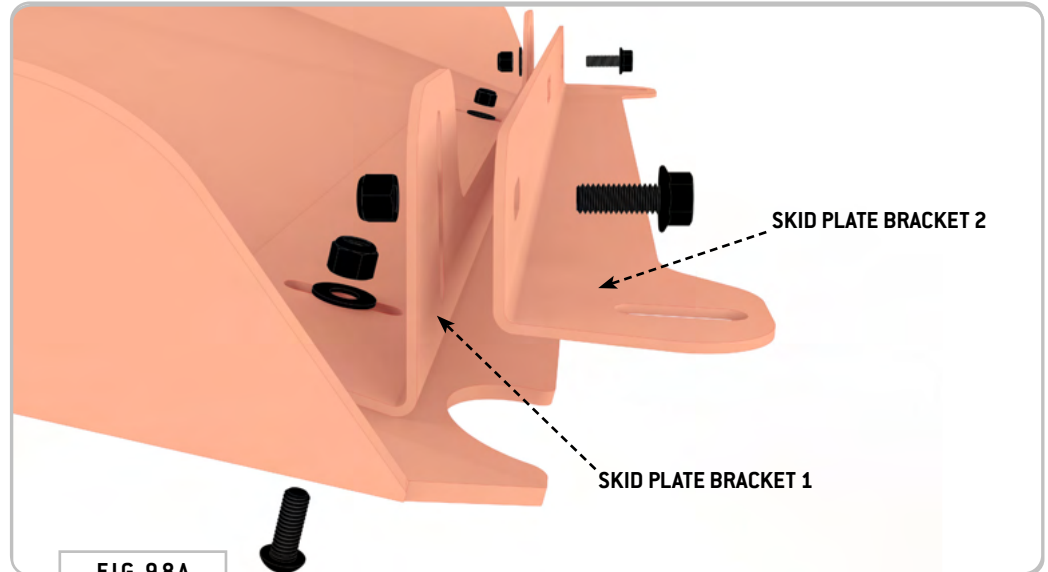

FIG 98A



FIG 99A

TOOLS REQUIRED FOR THIS STEP: + 13MM WRENCH OR SOCKET
+ 7/32" ALLEN WRENCH

[SKIP THIS PAGE IF 2023+ AWD]

STEP | 11 SKID PLATE INSTALL

11.1a Attach Skid Plate to Van: With help, attach the **Skid Plate** to the **Van Mounts** using the provided **M8-1.25 X 40 Flanged Hex Head Screws** through the available mounting slots of **Skid Plate Bracket 2** (FIG 100A+101A).

PRO-TIP: Hang the assembled **Skid Plate** to the **Recovery Hooks** of the **Winch Cradle** to take some weight off while you attach it to the van mounts.

11.2a Install Skid Plate to FVC Bumper: With the **Skid Plate** loosely secured to the **Van Mounts**, attach the front of the **Skid Plate** to the **FVC Bumper** by threading (4) **3/8-16 x 1 Hex Drive Screws** into the locations shown in FIG 102A.

11.3a Alignment and Fastening: Go back and tighten down all fasteners to hold the **Skid Plate** in place to the **Van Mounts** and **Bumper**.

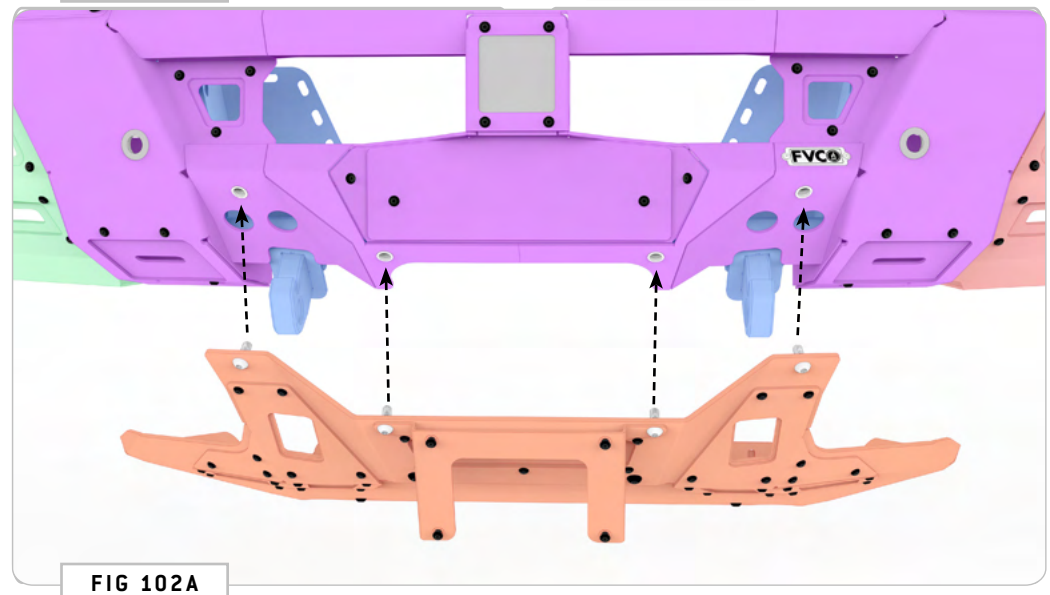

TOOLS REQUIRED FOR THIS STEP: + 7/32" ALLEN WRENCH
+ 9/16" WRENCH OR SOCKET

STEP | 10 AWD SKID PLATE PREP

10.8 Attach Clip Nuts to Frame: Attach Clip Nuts to the Van's Frame in the locations shown in FIG 98B and 99B.

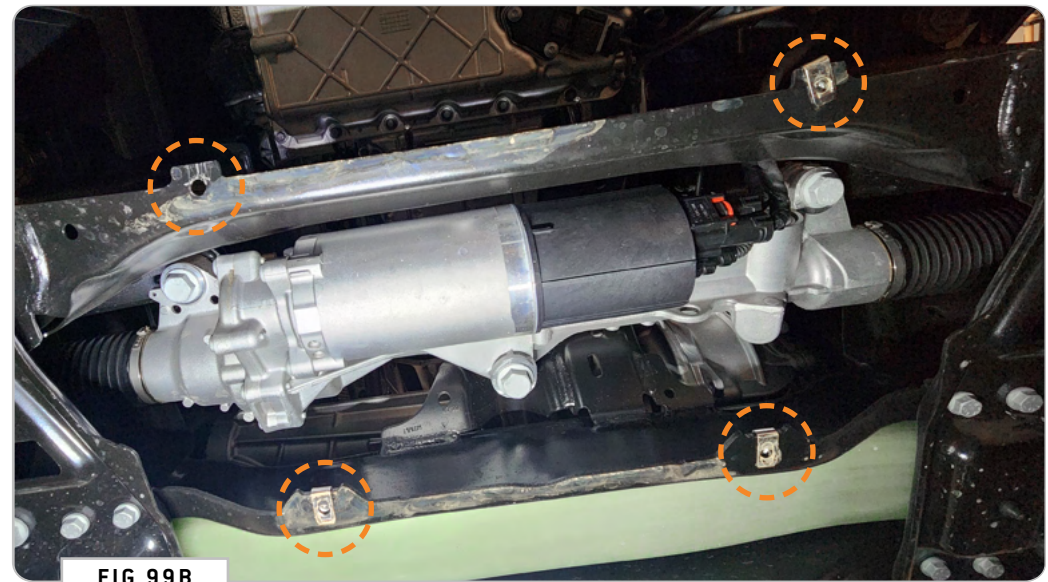
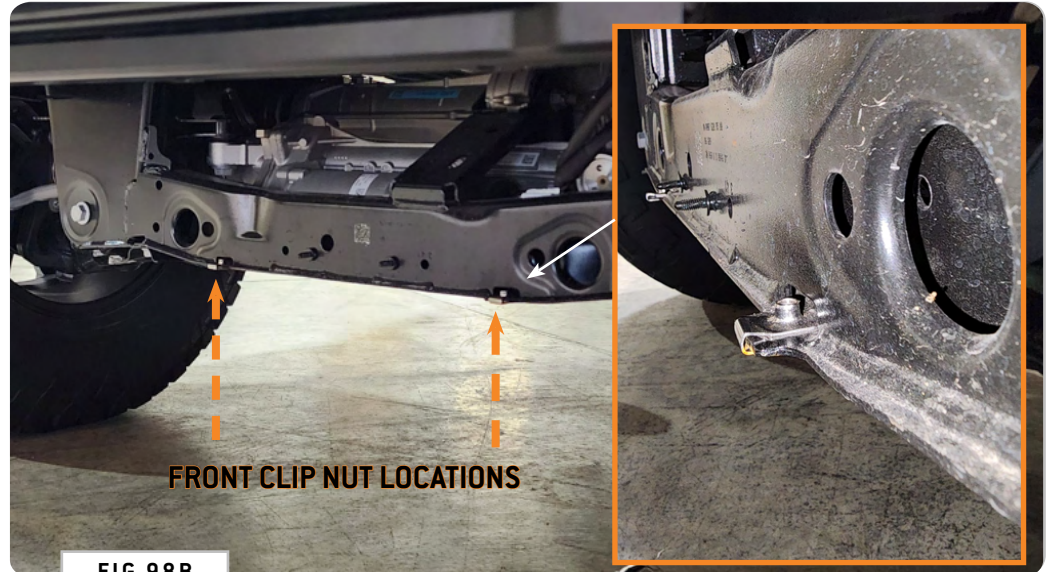

STEP | 11 AWD SKID PLATE INSTALL

11.1b Attach AWD Skid Plate Bracket to Van: Loosely attach the AWD Skid Plate Bracket to the Clip Nuts using the (4) 1/4 X 0.75 Flanged Hex Head Screws through the available mounting slots of Skid Plate Bracket 2 (FIG 100B).

11.2b Attach Skid Plate to AWD Bracket: With help, loosely attach the Skid Plate to the AWD Bracket using (2ea) 3/8-16 x 1 Hex Head Screws, 3/8" Flat Washers and Nylon Locknuts through the available mounting slots of Skid Plate Bracket 1 (FIG 101B).

PRO-TIP: Hang the assembled Skid Plate to the Recovery Hooks of the Winch Cradle to take some weight off while you attach it to the van mounts.

11.3b Install Skid Plate to FVC Bumper: With the Skid Plate loosely secured to the Van Mounts, attach the front of the Skid Plate to the FVC Bumper by threading (4) 3/8-16 x 1 Hex Drive Screws into the locations shown in FIG 102B.

11.4b Alignment and Fastening: Go back and tighten down all fasteners to hold the Skid Plate in place to the Van Mounts and Bumper.

TOOLS REQUIRED FOR THIS STEP: + 13MM WRENCH OR SOCKET
+ 7/32" ALLEN WRENCH
+ 5/32" ALLEN WRENCH



FIG 100B

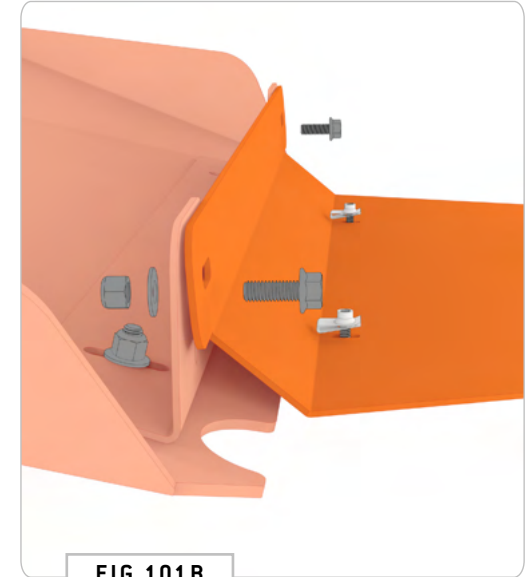

FIG 101B

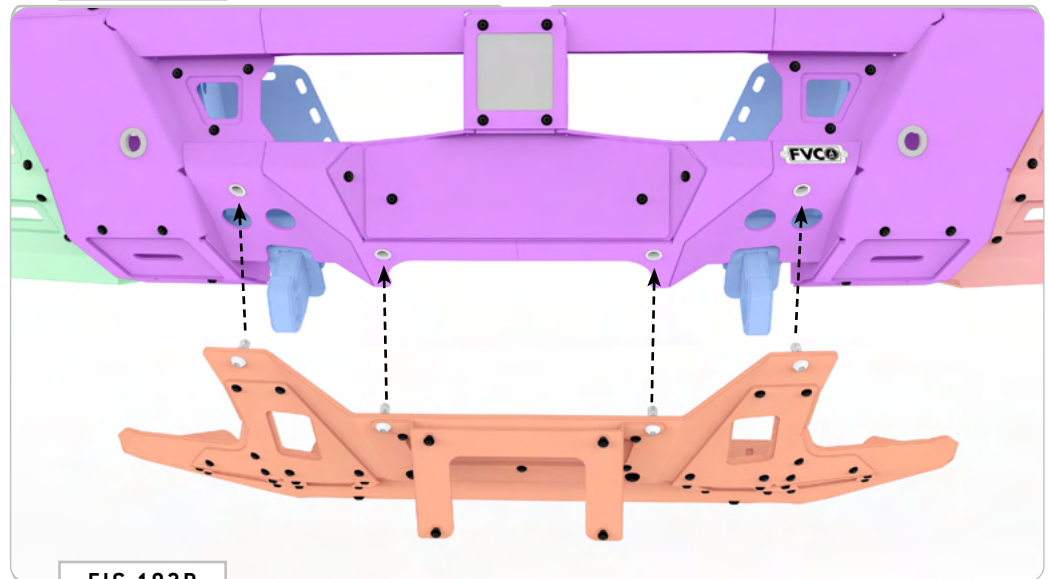

FIG 102B

TOOLS REQUIRED FOR THIS STEP: + 5/32" ALLEN WRENCH

STEP | 12 FINAL CHECKS AND TRIM

12.1 Remove Adaptive Radar Sensor Faceplate and Bracket: Remove the **Adaptive Radar Sensor Faceplate** and **Wrap-Around Bracket** to access the **Radar Sensor Cavity** (FIG 105).

12.2 Position Adaptive Radar Sensor Harness: Fish the **Adaptive Radar Sensor Harness** down and through the new mounting location shown in FIG 103.

NOTE - *If running a Winch, be sure to keep the wiring well out of the way of the Winch Rope by tying it off to the side (FIG 104).*

12.3 Install Adaptive Radar Sensor to Bumper: Assemble the **Radar Sensor Mounting Bracket** to the **Radar Sensor** and reconnect to the **Wiring Harness**. Position the assembly within the cavity and secure to the pre-installed **Clip Nuts** with (2) **1/4-20 x 0.5" Button Head Screws**. Cover with the **Plastic Faceplate** and **Bezel** using (4) **1/4-20 x 0.75" Button Head Screws** (FIG 105).

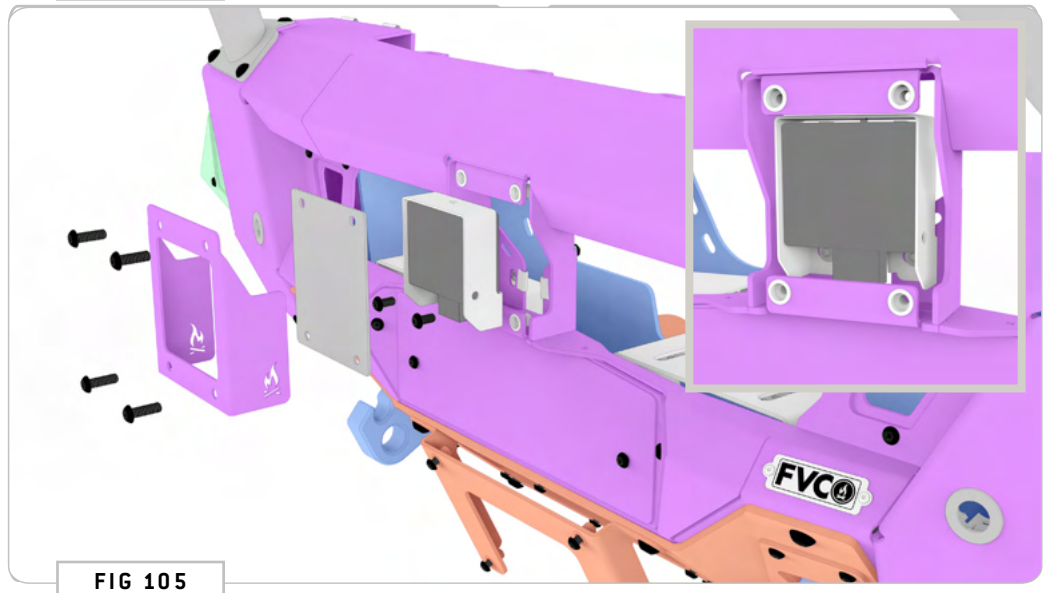

TOOLS REQUIRED FOR THIS STEP:

STEP | 12 FINAL CHECKS AND TRIM

12.4 Attach Trim Gaskets: Attach Trim Gaskets to the location shown in FIG 106+108 . (Repeat for Driver's Side)



TOOLS REQUIRED FOR THIS STEP:

STEP | 12 FINAL CHECKS AND TRIM

12.5 Replace Upper Bumper Skin: Hold the **Upper Bumper Skin (that houses the grille)** back into place in order to reconnect wiring harnesses (FIG 109).

12.6 Reconnect Fog Lights: Reconnect **Fog Light Harness to Van Fog Lights** (FIG 110).

12.7 Reconnect Camera: Plug the **Front Camera Harness (or Camera itself)** back in to the **Camera Bezel** in the orientation that you removed it (FIG 111).

12.8 Reconnect Ambient Air Sensor: Reconnect the **Ambient Air Sensor** to its original location (FIG 112).



FIG 109



FIG 110



FIG 111



FIG 112

TOOLS REQUIRED FOR THIS STEP: + T25 TORX

STEP | 12 FINAL CHECKS AND TRIM

12.9 Reposition Park Sensors: Plug the **Park Sensors** back in to their original locations as shown in **FIG 113+114** and reconnect the **Park Sensor Harness** to back to the van.

12.10 Secure Upper Bumper Skin: Secure the **Upper Bumper Skin** to the van by using a **T25 Torx** and the three factory screws retained from step 3.1.



INSTALL

STEP | 12 FINAL CHECKS AND TRIM

12.11 Install Winch Rope to Hook: If you installed a **Winch Fairlead**, install the **Winch Fairlead Hook** to the **Winch Rope** by installing the stainless steel **Pin** and **Internal Retaining Ring**.

NOTE - *Snap ring pliers are required for this step. Make sure the retaining ring is fully seated in its groove.*

12.12 Stow the Hook: Slowly retract the winch to stow the hook in place. Be careful not to retract too fast to avoid pinching fingers or damaging the bumper.

TOOLS REQUIRED FOR THIS STEP: + SNAP RING PLIERS



GET OUT AND EXPLORE!

+ LEAVE US A REVIEW

Happy with your new FVC product? We would love to hear (and see) from you! Head to the product page and click "Leave Review." Add a short review and upload a few photos to be showcased on the product page.

+ SHARE YOUR PICS

We love seeing how our customers use their FVC products and following along with your adventures. Tag us in your photos with: @flatlinevanco or send them to us via email. We love posting customer pictures in our feed!

+ NEED ANY HELP?

If you are having any issues with your product, please reach out, and we will make it right. FVC is a company of van and outdoor enthusiasts that design and use our own products, so we want you to be as stoked on your new parts as we are!



@FLATLINEVANCO