



INSTALLATION GUIDE

SPRINTER VAN REAR TIRE CARRIER

SP1117B



TOOLS REQUIRED (NOT INCLUDED)

- | | |
|---------------------|---------------------------|
| + 9/16" WRENCH | + 13/16" DEEP SOCKET |
| + 3/4" WRENCH | + 3/16" DRILL BIT |
| + 7/32" ALLEN KEY | + 1/4" DRILL BIT |
| + 5MM ALLEN KEY | + POWER DRILL |
| + RATCHET | + AUTO PANEL REMOVAL TOOL |
| + 9/16" DEEP SOCKET | |

INSTALL INFO

TIME TO INSTALL THIS PRODUCT: 1 HOUR

Additional help is suggested for a few of the install steps.

BEFORE YOU START

Please inspect the product and packaging upon delivery to ensure there are no issues and that all parts and hardware are accounted for.

Contact us ASAP if anything is missing at:

support@flatlinevanco.com

BEFORE YOU START

All Flatline Van Co products must be properly assembled and secured before attaching to your vehicle. Improper attachment could result in an automobile accident, and could cause serious bodily injury or death to you or to others involved. You are responsible for assembling and securing Flatline Van Co products to your vehicle, checking the mounting points and attachments prior to use, and regularly inspecting the products for wear and or damage. We always recommend you use a professional to install any aftermarket accessories to your vehicle. If you have no mechanical experience and are not thoroughly familiar with the installation procedures, you must have the product installed by a professional installer or other qualified persons. The responsibility is yours and must be taken seriously for everyone's safety.



PACKAGE CONTENTS

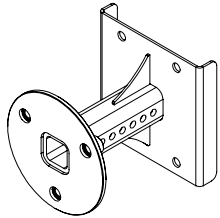

WHEEL BRACKET
QTY: 1

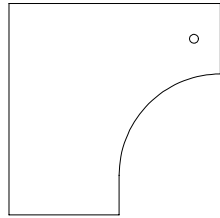

DRILL TEMPLATE
QTY: 1

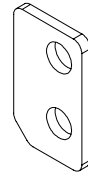

**LOWER HINGE BACKING
PLATE**
QTY: 1



**UPPER HINGE BACKING
PLATE**
QTY: 1

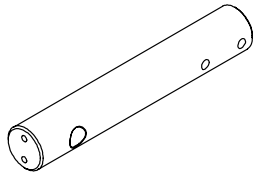

LOCK ROD
QTY: 1



BACKER PLATE
QTY: 2

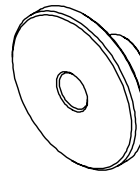

DOOR MOUNTING BOSS
QTY: 1

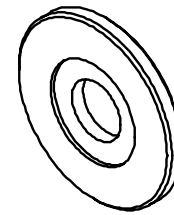

BUSHING CAP
QTY: 1

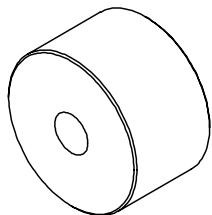

TALL BUSHING
QTY: 1

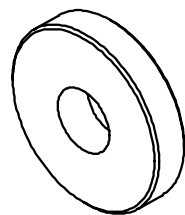

SHORT BUSHING
QTY: 1

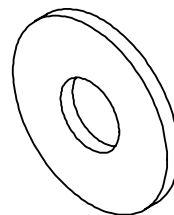

SEALING WASHER
QTY: 1

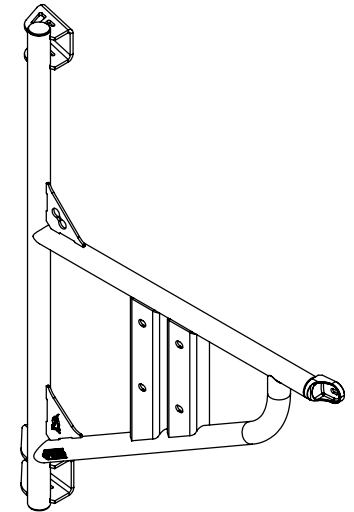

TIRE CARRIER FRAME
QTY: 1

HARDWARE

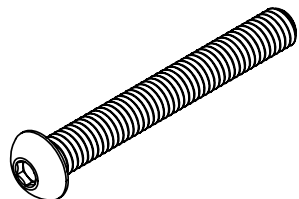

3/8-16 X 3 BUTTON HEAD
HEX DRIVE SCREW

QTY: 1

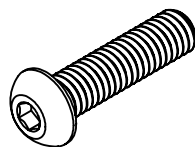

3/8 x 1.5 HEX DRIVE
BUTTON HEAD SCREW

QTY: 4

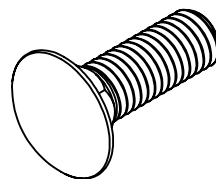

1/2-13 X 1.5 SQUARE NECK
CARRIAGE BOLT

QTY: 4

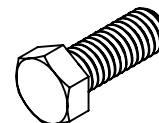

3/8-16 x 1 HEX HEAD SCREW

QTY: 2

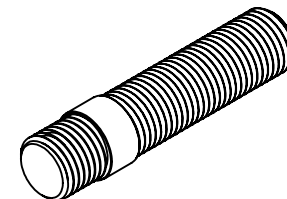

M14-1.5 X 65 WHEEL STUD

QTY: 3

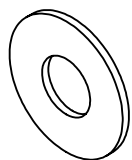

1/2 SCREW FLAT WASHER

QTY: 4



3/8 FLAT WASHER

QTY: 3

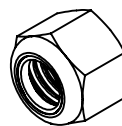

1/2-13 NYLON LOCKNUT

QTY: 4



3/8-16 NYLON LUCKNUT

QTY: 5

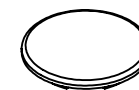

0.787 I.D. SNAP IN PANEL
PLUG

QTY: 1

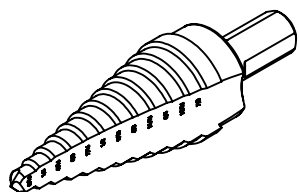

MULTIDIAMETER DRILL BIT

QTY: 1

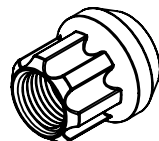

M14-1.5 LUG NUT

QTY: 3

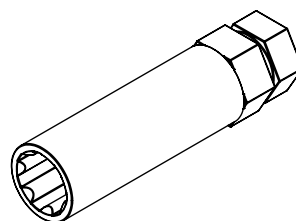

LUG NUT KEY

QTY: 1

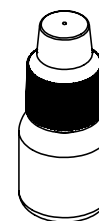

THREAD LOCKER

QTY: 1

INSTALL

TOOLS REQUIRED FOR THIS STEP: + AUTO PANEL REMOVAL TOOL

STEP | 01 LAYOUT AND INSTALL PREP

1.1 Door Panel Removal: If applicable, start by removing the lower interior door panel (**FIG 1**) and any obstructions in the area shown in **FIG 2** (wires, insulation, etc.). We recommend using plastic panel removal tools (easily found at harbor freight or similar). Be gentle when prying as to not break the factory panel clips. Once you get the first few popped you should be able to pull it the rest of the way with your hands.

NOTE- You may have any number of different door configurations- stock full trim (**Pictured FIG 1**), stock half trim, stock panel, upholstered wood, etc. Each require their own removal method. Please note that the panel-style trimmed door requires additional drilling and the use of the provided **panel plug** (**See Step 2.5**).

NOTE - This product is compatible with 2019 and newer vans with 180-degree rear door hinges. If your van has 270-degree hinges, you'll need to have them swapped out for 180-degree hinges. You can find them available for purchase [here](#).

NOTE - You may need to migrate the factory rubber bump stop from your original hinges to your new 180-degree hinges.

NOTE- Sometimes the clips will get stuck in the door. All you need to do is pop them out and slide them back in to their location on the trim panel.

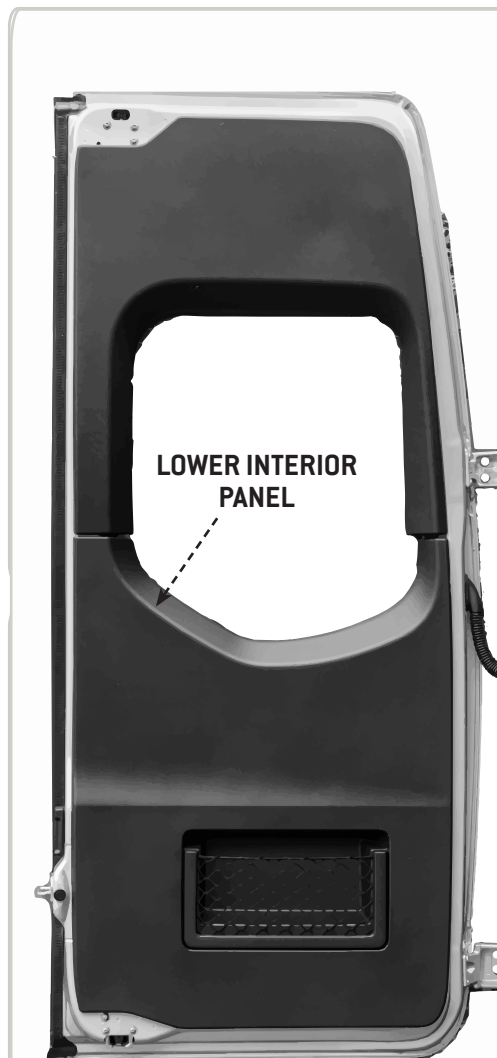

FIG 1

*FULL STOCK TRIM



FIG 2

STEP | 02 DRILL THIRD MOUNT

2.1 Template Marking: Align the drill template with the van's body lines and mark the spot as shown in **FIG 3**.

2.2 Pilot Hole: Drill a pilot hole through the first layer of metal using a **3/16" Drill Bit (FIG 4)**.

NOTE - This hole is sized to fit a 9/16" deep well socket to make fastening easier.

2.3 Drilling Steps: Drill through all with a **3/8" Drill Bit (FIG 5)**.

2.4 Drill Out Third Mount: Use a **Step Bit** to drill the outside hole to 5/8" to fit the **Door Mounting Boss** (do not install yet).

PRO-TIP: We like to mark the step bit as shown in **(FIG 6)** to avoid drilling too far.

2.5 Panel Style Door Trim (If Applicable): If you have the panel style door trim, drill through again using a **1/4" or similar sized bit** that is long enough to reach the sheet metal on the backside. Drill the inside hole out to 7/8" to fit the panel plug.

TOOLS REQUIRED FOR THIS STEP:

- + MARKER
- + 3/16" DRILL BIT
- + 1/4" DRILL BIT
- + 3/8" DRILL BIT
- + STEP BIT



FIG 3

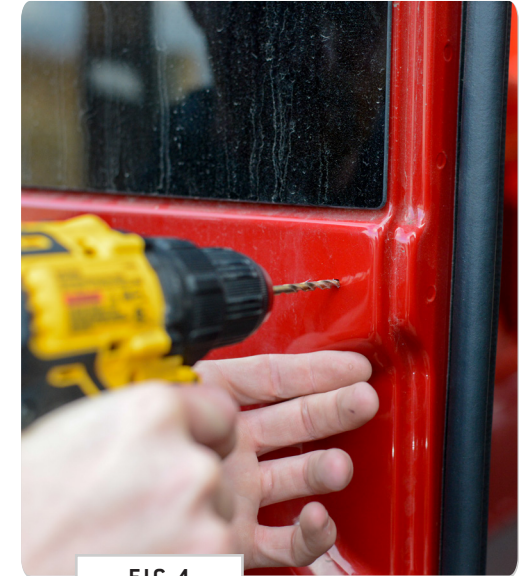

FIG 4



FIG 5



FIG 6

STEP | 03 BRACKET ASSEMBLY

3.1 Assemble the Tire Carrier: Attach the Wheel Bracket to the tire carrier frame using: (2) Backer Plates, (4) 1/2-13 X 1.5 Square Neck Carriage Bolts, (4) 1/2 Screw Flat Washers, And (4) 1/2-13 Nylon Insert Locknuts and a 3/4" Wrench or Socket.

3.2 Lock Rod: Fasten using (2) 3/8-16 X 1 Hex Head Screws and a 9/16" Wrench or Socket. The depth is adjustable to suit your specific wheel setup.

Optional: If you have locking lug nuts, skip the lock rod installation for a clean look.

TOOLS REQUIRED FOR THIS STEP: + 3/4" WRENCH OR SOCKET
+ 9/16" WRENCH OR SOCKET

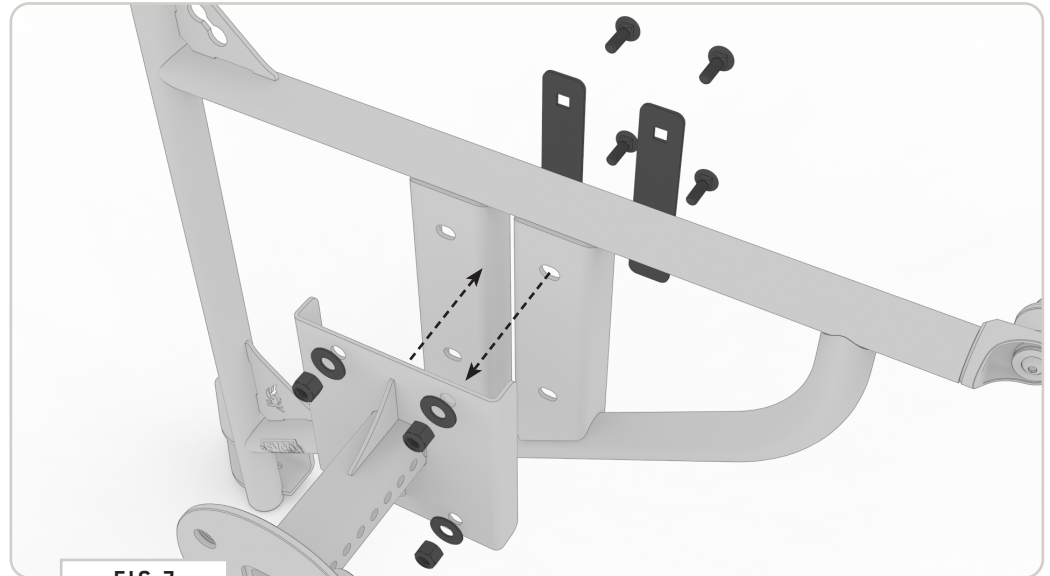

FIG 7

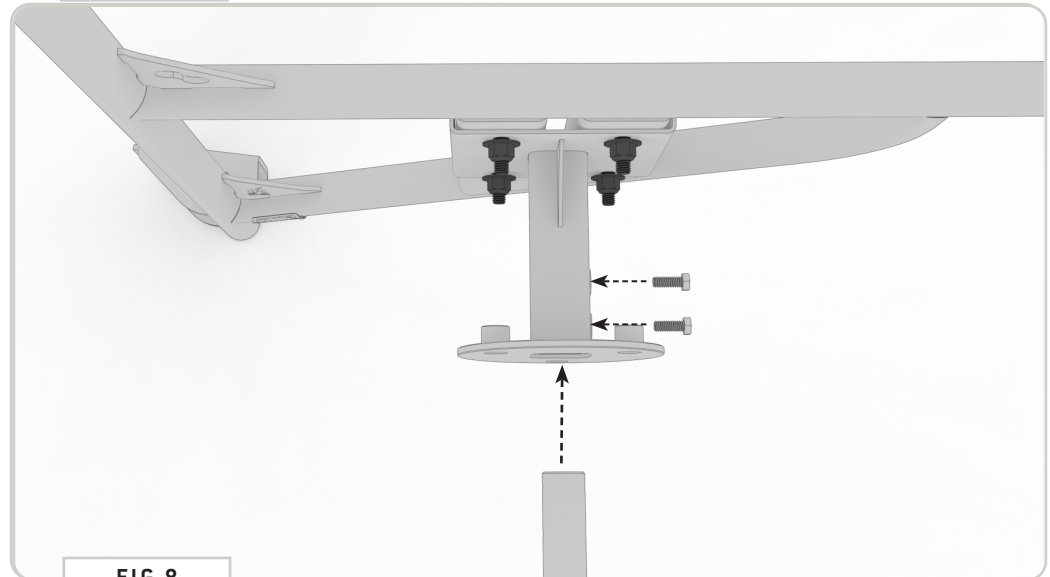

FIG 8

TOOLS REQUIRED FOR THIS STEP:

STEP | 04 VAN MOUNTS

4.1 Hinge Backing Plates: Grab both hinge backing plates and (4) 3/8-16 X 1.5 Hex Drive Button Head Screws. Place them into the back of your 180 hinges as shown in FIG 9 and FIG 10.

4.2 Bushing Assembly for Third Mount: Gather 3/8-16 x 3" Button Head Hex Drive Screw, Bushing Cap, Short Bushing, Tall Bushing, Mounting Boss and Sealing Washer and assemble onto the carrier as shown in FIG 11.

NOTE - A second person is suggested to hold the carrier in place for the following steps.

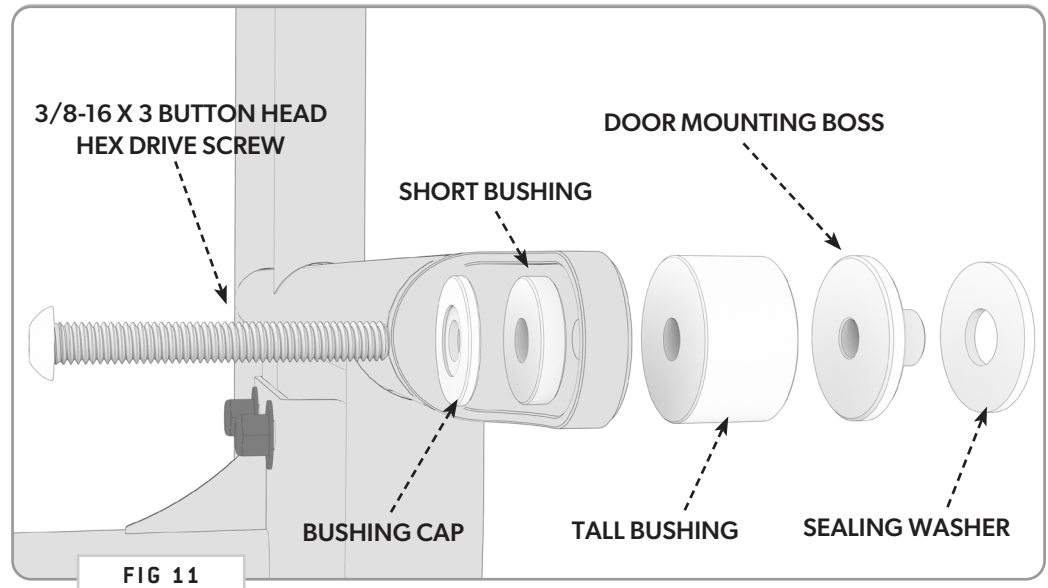
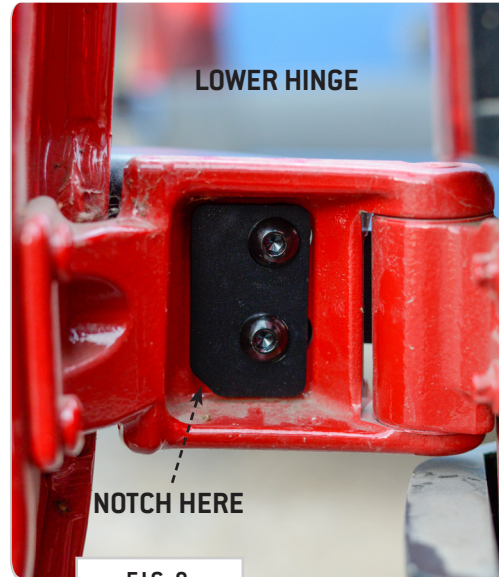

STEP | 05 SECURE CARRIER

5.1 Third Mount: Holding up the assembled carrier to the door, insert the bushing assembly through the third mount hole to center the carrier while you secure it to the hinge mounts in the next step.

5.2 Hinge Mount: Fit the tire carrier onto the protruding hardware of the hinges and loosely secure with **(4) 3/8 Washers and Nylon Locknuts** (FIG 12).

5.3 Secure Bushing Assembly: Using a **3/8" Flat Washer and 3/8" Nylon Locknut**, tighten the Bushing Assembly with a **9/16" Socket and 7/32" Allen Wrench** to the point where the tall bushing shows a slight compression (Shown in FIG 14).

PRO-TIP: *If you had to drill out the inside of your door to access the third mount hole, use a couple flathead screwdrivers to attach the 3/8" Washer to the 3/8-16 x 3" Button Head Hex Drive Screw before using the deep well socket to thread on your 3/8" Nylon Locknut (FIG 13).*

5.4 Alignment: Align the tire carrier with the door/window body lines. Open the door to ensure the door stop on the lower hinge bracket engages the factory bump stop. Tighten all fasteners on the hinges (FIG 15).

TOOLS REQUIRED FOR THIS STEP:

- + 9/16" DEEP SOCKET
- + 9/16" WRENCH
- + 7/32" ALLEN WRENCH

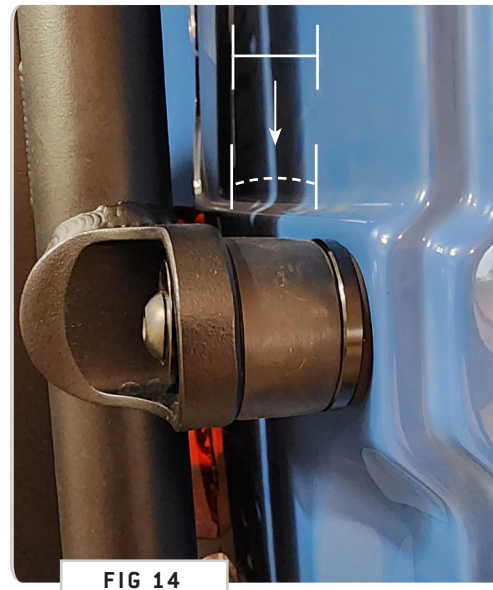
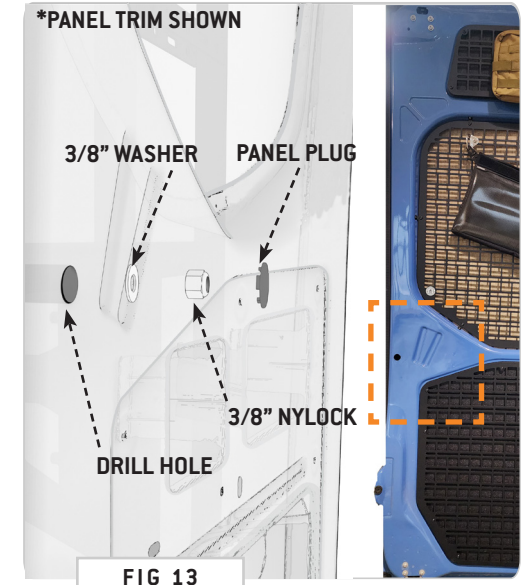
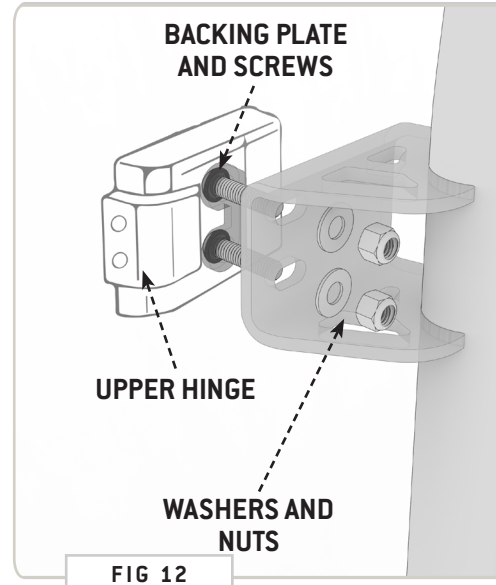

STEP | 06 ATTACH WHEEL

6.1 Wheel Studs and Lug Nuts: Apply Loctite to the **Wheel Studs** on the short end and screw them into the **Wheel Bracket**. Tighten with a **5mm Allen Wrench** (**FIG 16**).

6.2 Attach the Wheel: Lift your wheel onto the carrier and fasten the **Lug Nuts** using the supplied **Lug Nut Key**. Tighten well with a **13/16" Socket** (**FIG 17**).

NOTE - If you are running a **Stock Wheel**, you'll need to purchase a **M14 Conical-to-Ball Seat Adapter** for the **Lug Nuts** to ensure a proper fitment.

TOOLS REQUIRED FOR THIS STEP: + 5MM ALLEN WRENCH
+ 13/16" SOCKET

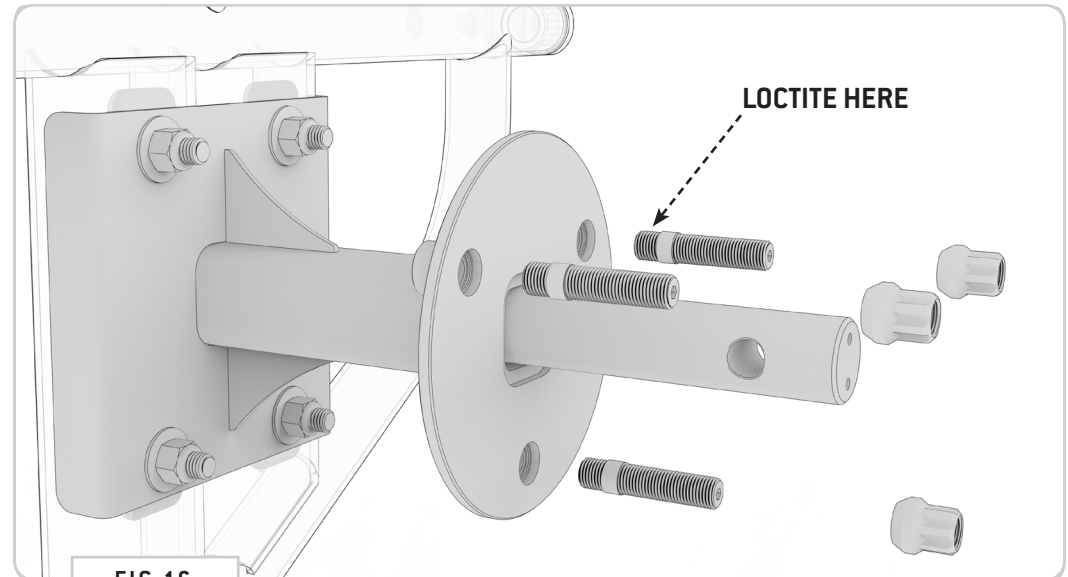

FIG 16

NOTE

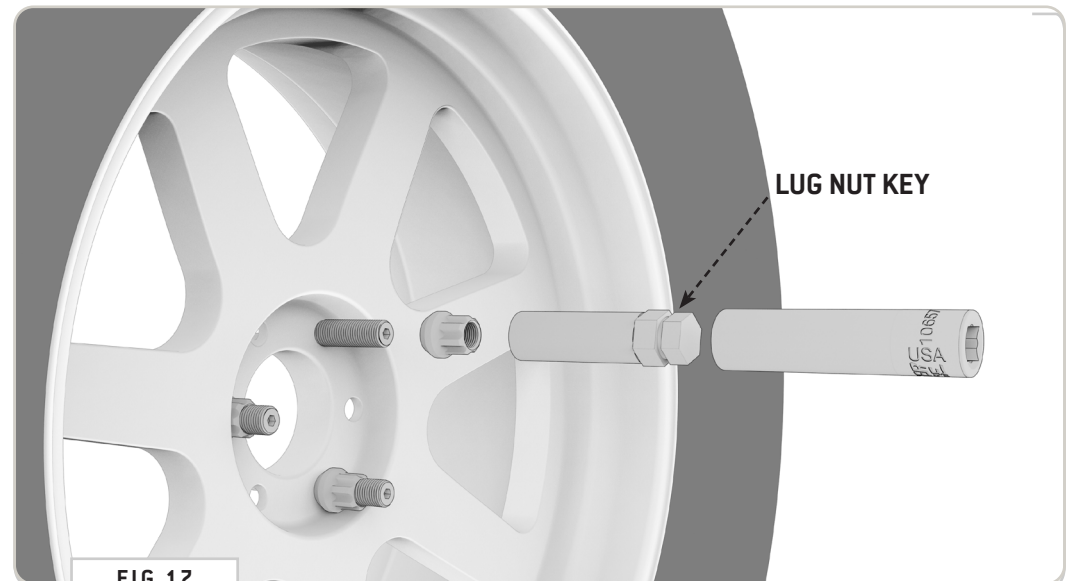
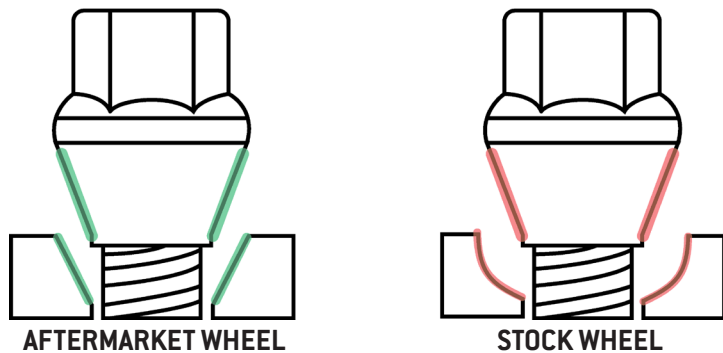
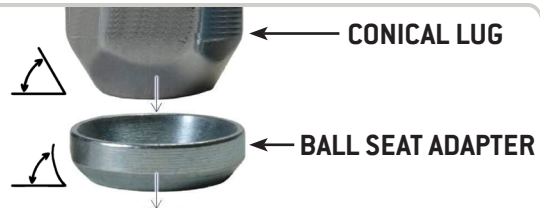

FIG 17

GET OUT AND EXPLORE!

+ LEAVE US A REVIEW

Happy with your new FVC product? We would love to hear (and see) from you! Head to the product page and click "Leave Review." Add a short review and upload a few photos to be showcased on the product page.

+ SHARE YOUR PICS

We love seeing how our customers use their FVC products and following along with your adventures. Tag us in your photos with: @flatlinevanco or send them to us via email. We love posting customer pictures in our feed!

+ NEED ANY HELP?

If you are having any issues with your product, please reach out, and we will make it right. FVC is a company of van and outdoor enthusiasts that design and use our own products, so we want you to be as stoked on your new parts as we are!



@FLATLINEVANCO