



INSTALLATION GUIDE

SPRINTER VAN STANDARD ROOF RACK - 144" HR WITH LIGHT BAR SP0128B



TOOLS REQUIRED (NOT INCLUDED)

- + MEASURING TAPE
- + 7/32" ALLEN WRENCH
- + 3/16" ALLEN WRENCH
- + 5/32" ALLEN WRENCH
- + 7/16" WRENCH OR SOCKET

INSTALL INFO

TIME TO INSTALL THIS PRODUCT: 1-2 HOURS

Additional help is suggested for a few of the install steps.

BEFORE YOU START

Please inspect the product and packaging upon delivery to ensure there are no issues and that all parts and hardware are accounted for.

Contact us ASAP if anything is missing at:
support@flatlinevanco.com

BEFORE YOU START

All Flatline Van Co products must be properly assembled and secured before attaching to your vehicle. Improper attachment could result in an automobile accident, and could cause serious bodily injury or death to you or to others involved. You are responsible for assembling and securing Flatline Van Co products to your vehicle, checking the mounting points and attachments prior to use, and regularly inspecting the products for wear and or damage. We always recommend you use a professional to install any aftermarket accessories to your vehicle. If you have no mechanical experience and are not thoroughly familiar with the installation procedures, you must have the product installed by a professional installer or other qualified persons. The responsibility is yours and must be taken seriously for everyone's safety.



PACKAGE CONTENTS

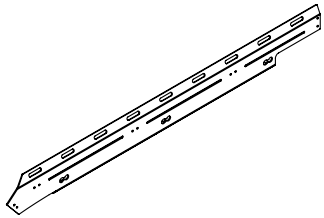

DRIVER FRONT SIDE RAIL

QTY: 1

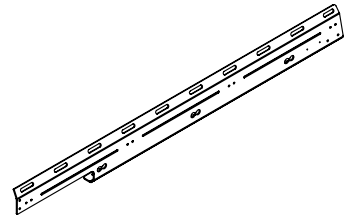

DRIVER REAR SIDE RAIL

QTY: 1

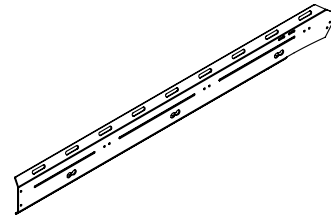

PASSENGER FRONT SIDE RAIL

QTY: 1

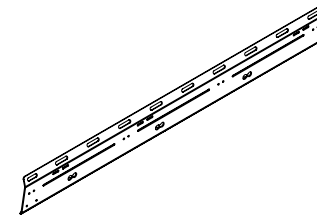

PASSENGER REAR SIDE RAIL

QTY: 1

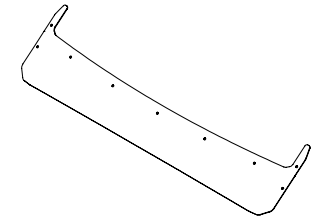

FRONT FAIRING

QTY: 1

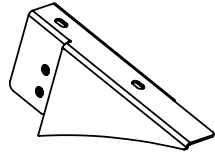

DRIVER SIDE FAIRING
BRACKET

QTY: 1

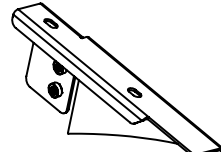

PASSENGER SIDE FAIRING
BRACKET

QTY: 1

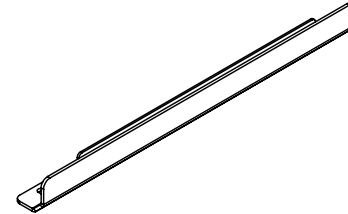

SIDE LADDER ACCESS COVER

QTY: 1

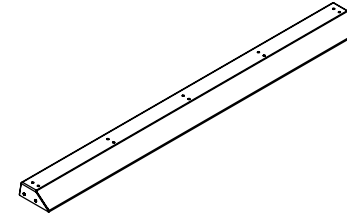

REAR SPOILER

QTY: 1

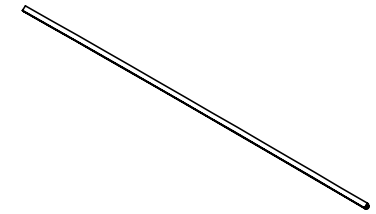

FAIRING GASKET TRIM

QTY: 1

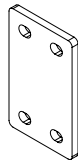

LARGE COUPLER PLATE

QTY: 1

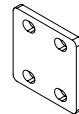

SMALL COUPLER PLATE

QTY: 1

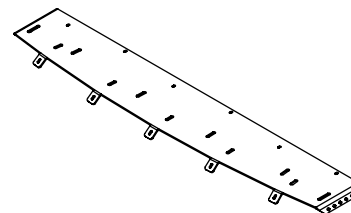

CROSSBAR FAIRING BRACKET

QTY: 1

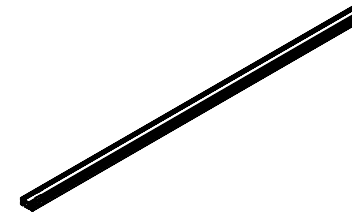

CROSSBAR

QTY: 7

HARDWARE

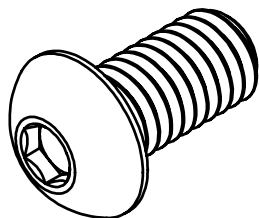

3/8-16 X 0.75 BUTTON
HEAD HEX DRIVE
SCREW

QTY: 14

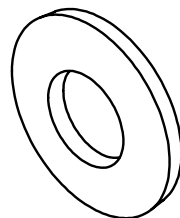

3/8 SCREW BELLEVILLE
SPRING LOCK
WASHER

QTY: 14

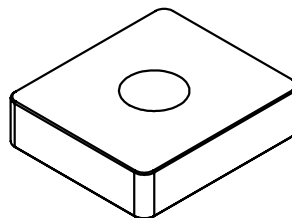

SPRINTER RAIL NUT

QTY: 14

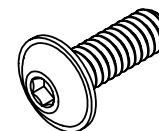

1/4-20 X 0.75
FLANGED BUTTON
HEAD HEX DRIVE
SCREW

QTY: 53

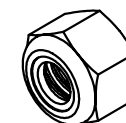

1/4-20
NYLON LOCKNUT

QTY: 17

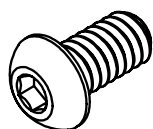

1/4-20 X 0.5 BUTTON
HEAD HEX DRIVE
SCREW

QTY: 16



1/4 SCREW BELLEVILLE
SPRING LOCK
WASHER

QTY: 16



1/4 SCREW FLAT
WASHER

QTY: 33

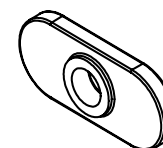

1/4-20 TNUT

QTY: 16

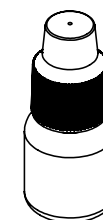

THREADLOCKER

QTY: 1

TOOLS REQUIRED FOR THIS STEP: + MEASURING TAPE

STEP | 01 LAYOUT AND INSTALL PREP

1.1 Install Rail Nuts: Slide (6) Rail Nuts into the passenger side factory roof rail (FIG 1), and (8) into the driver side rail. The extra two will be for either your Side Ladder or Side Ladder Access Cover.

1.2 Layout Rail Nuts: Space out the Rail Nuts close to their final positions as roughly laid out in FIG 3.

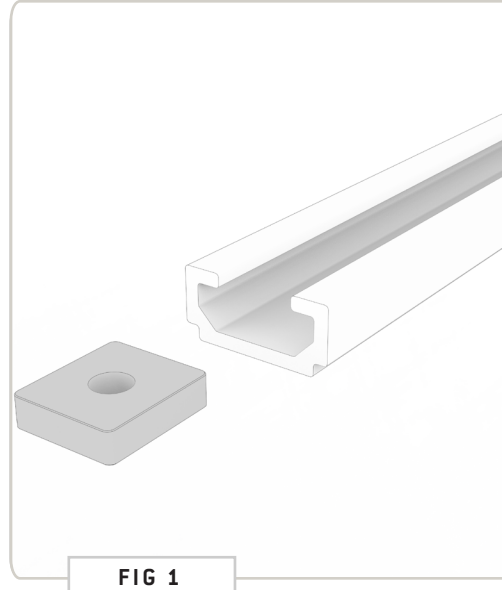

FIG 1

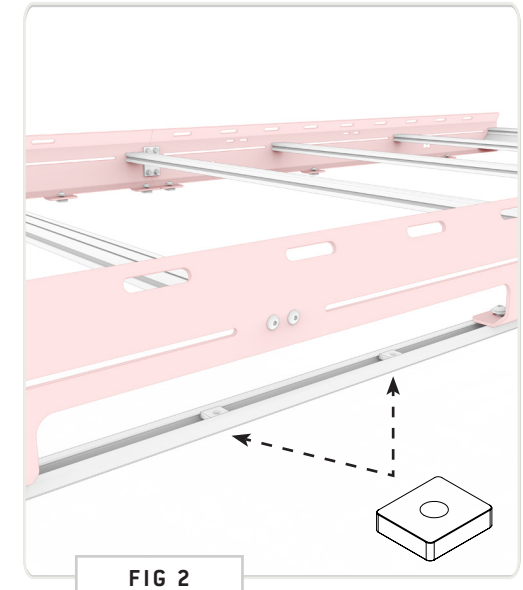

FIG 2

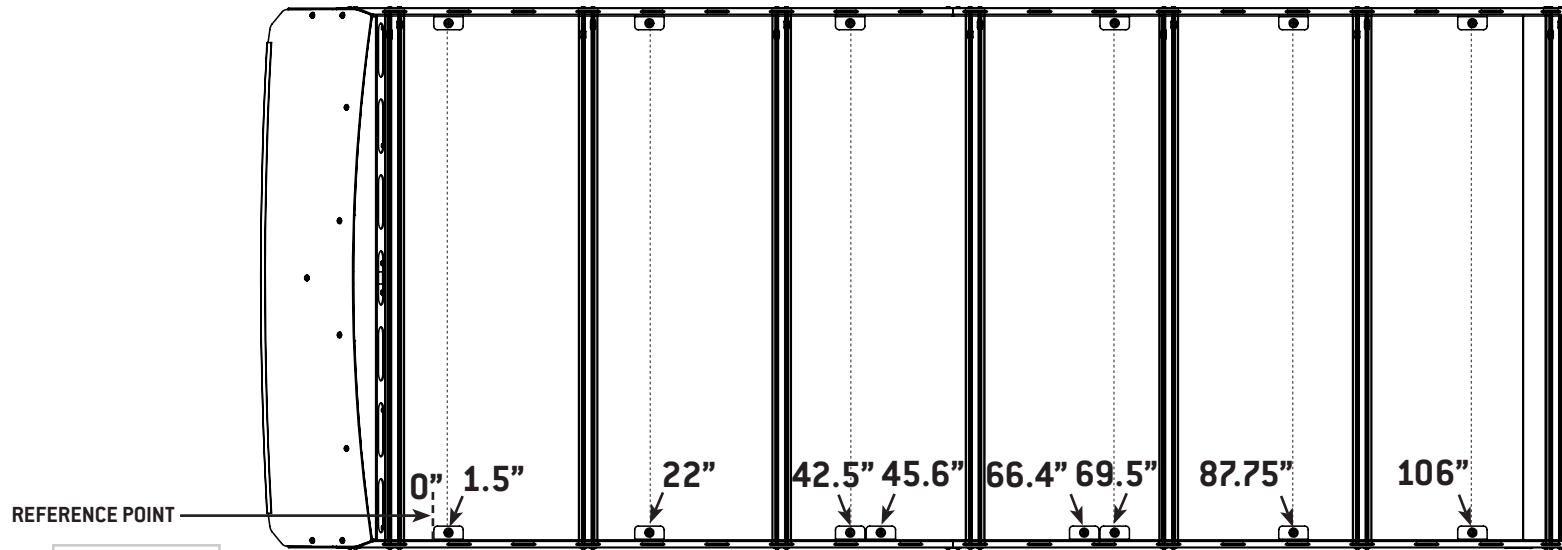

FIG 3

TOOLS REQUIRED FOR THIS STEP: + 7/32" ALLEN WRENCH

STEP | 02 SIDE RAIL INSTALL

2.1 Install Side Rails: Beginning with the forward section of the rack (see FIG 5 for layout), start loosely attaching the side rails to the roof rails using the **3/8-16" Button Head Screws & 3/8" Lock Washers**, but do not tighten them all the way down yet (FIG 4). If you are not installing a **Side Ladder** at this time, install the **Side Ladder Access Cover** in the location shown in FIG 5.

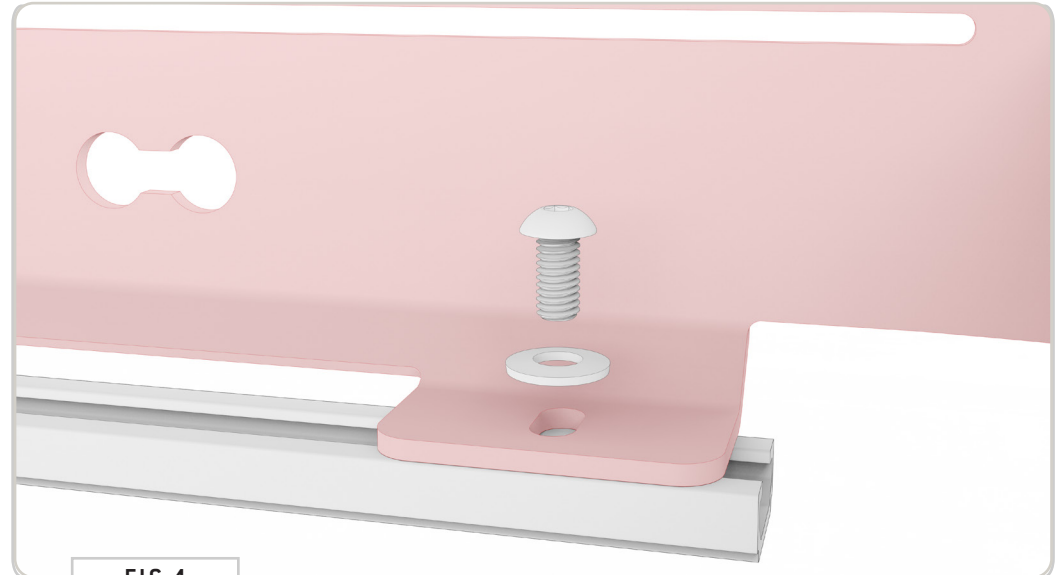

FIG 4

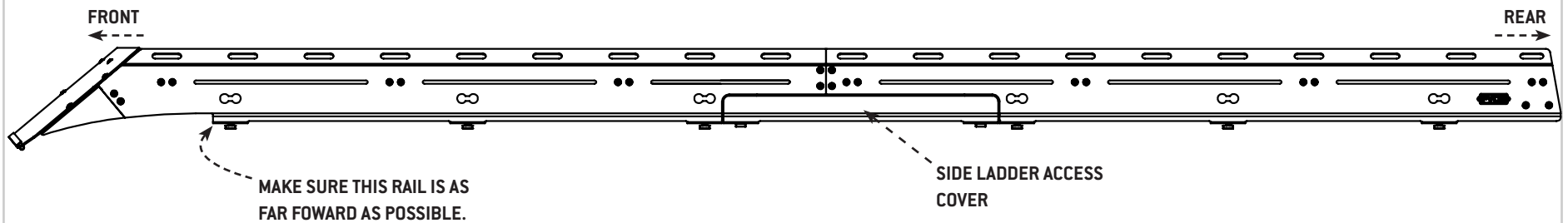
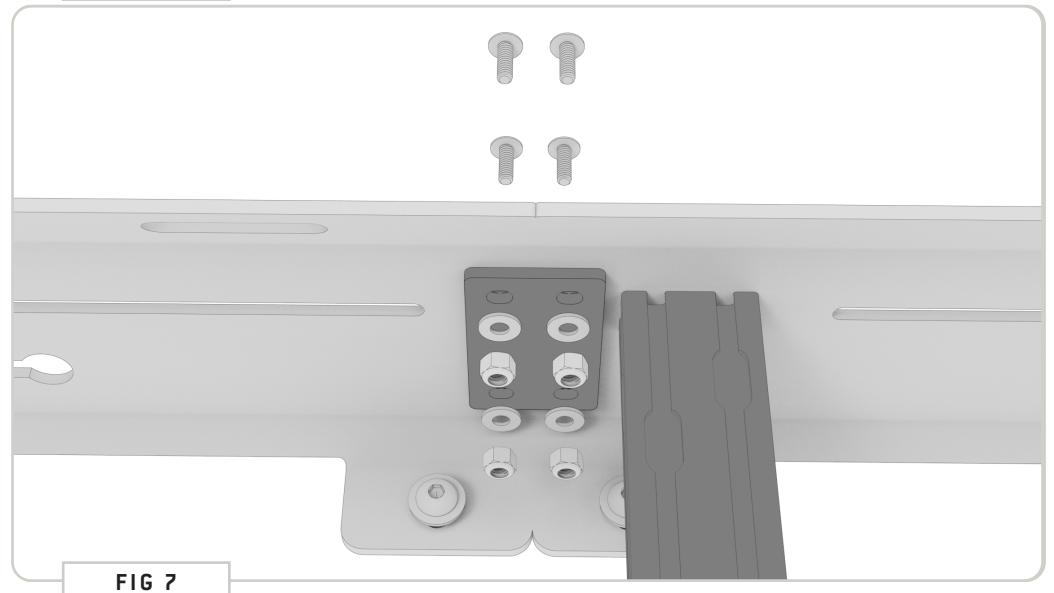
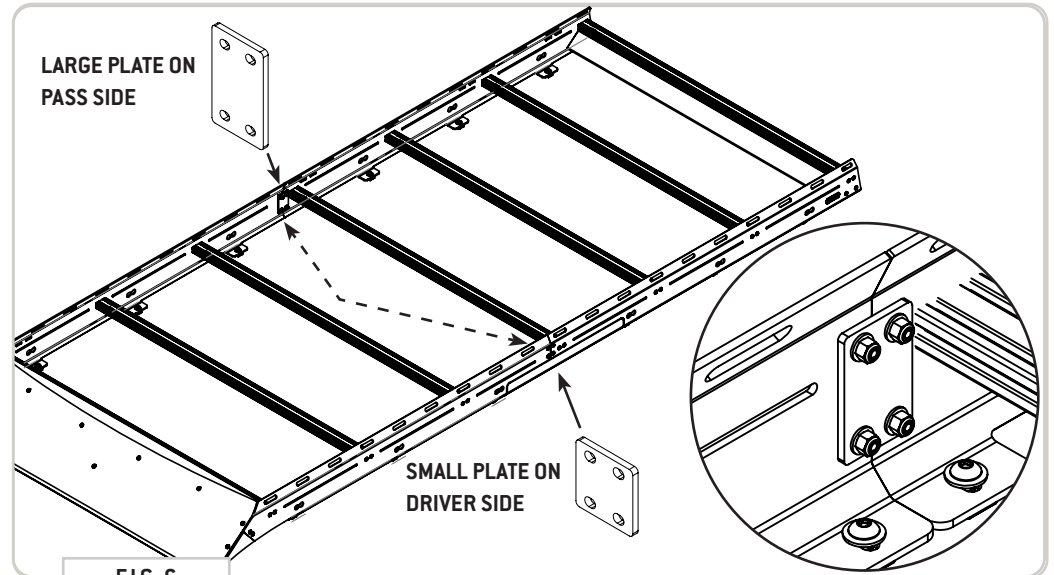

FIG 5

STEP | 02 SIDE RAIL INSTALL

2.2 Side Rail Connecting Plates: Install the **Side Rail Connecting Plates** to the locations shown in FIG 6 using (4ea) **1/4-20 x 0.75 Flanged Button Head Screws, Flat Washers and Nylon Locknuts** to loosely join the Side Rails together (FIG 7).

TOOLS REQUIRED FOR THIS STEP: + 3/16" ALLEN WRENCH
+ 7/16" SOCKET OR WRENCH



TOOLS REQUIRED FOR THIS STEP: + 3/16" ALLEN WRENCH

STEP | 03 CROSSBAR INSTALL

3.1 Layout Crossbar Locations: Position the crossbars in your desired locations, loosely threading in the **1/4-20" Flange Head Screws** to hold in place (**FIG 8**).

NOTE - Save a crossbar for Fairing Assembly in the next step.

NOTE - Keep in mind the layout of your roof top array (solar panels, fans, tents, etc.) You can mount crossbars in the set pair of holes (**FIG 9**), or you can place them in the slots which provides you more freedom of layout.

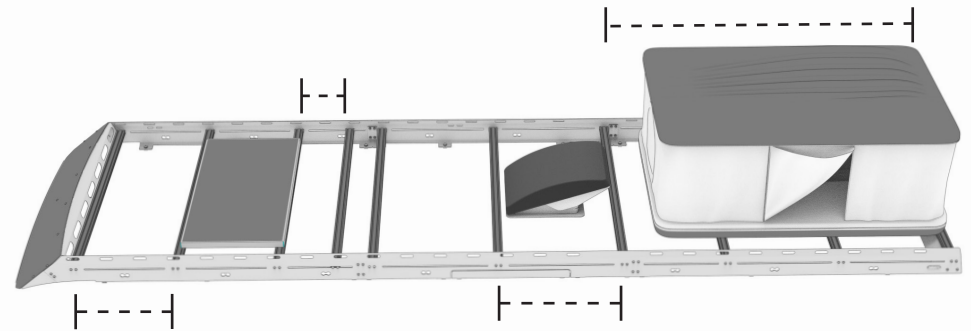

FIG 8

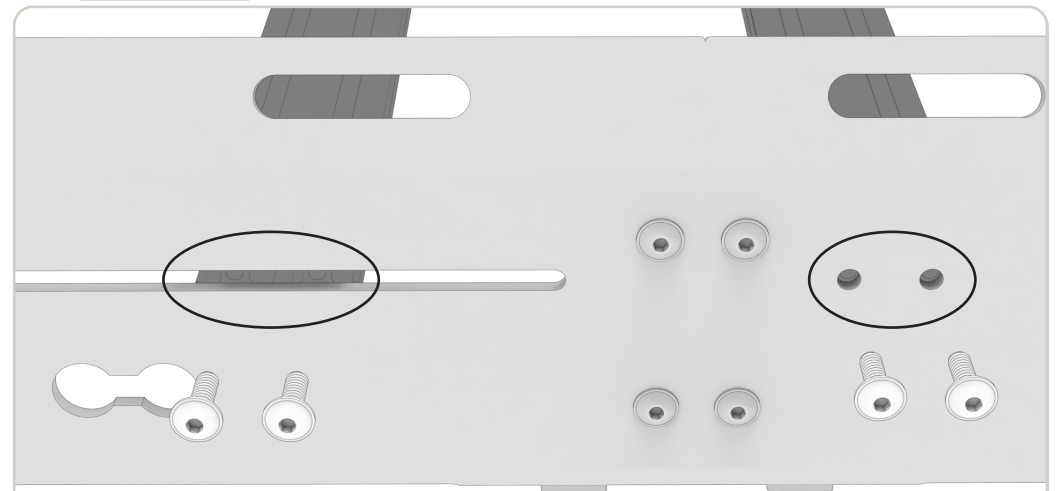

FIG 9

STEP | 04 FAIRING ASSEMBLY

4.1 Crossbar Fairing Bracket: Stack a 1/4-20" x 0.5 Button Head Screw, 1/4" Belleville Lock Washer and 1/4" Flat Washer as shown in FIG 10 and insert into the six available front holes of the Crossbar Fairing Bracket. Loosely assemble using a T-Nut. You'll only want to screw the T-Nuts on a little in order to provide clearance for the next step.

4.2 Crossbar Install: Now, slide the Crossbar onto the Crossbar Fairing Bracket. You'll have to straighten each T-Nut as you go to get it to feed into the crossbar correctly (FIG 11).

TOOLS REQUIRED FOR THIS STEP: + 5/32" ALLEN WRENCH

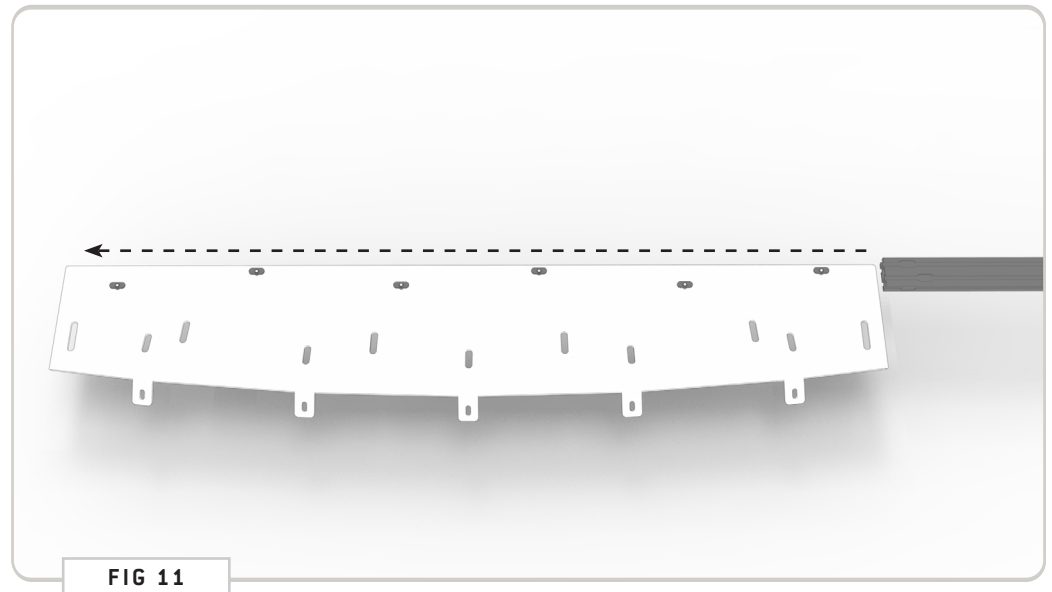
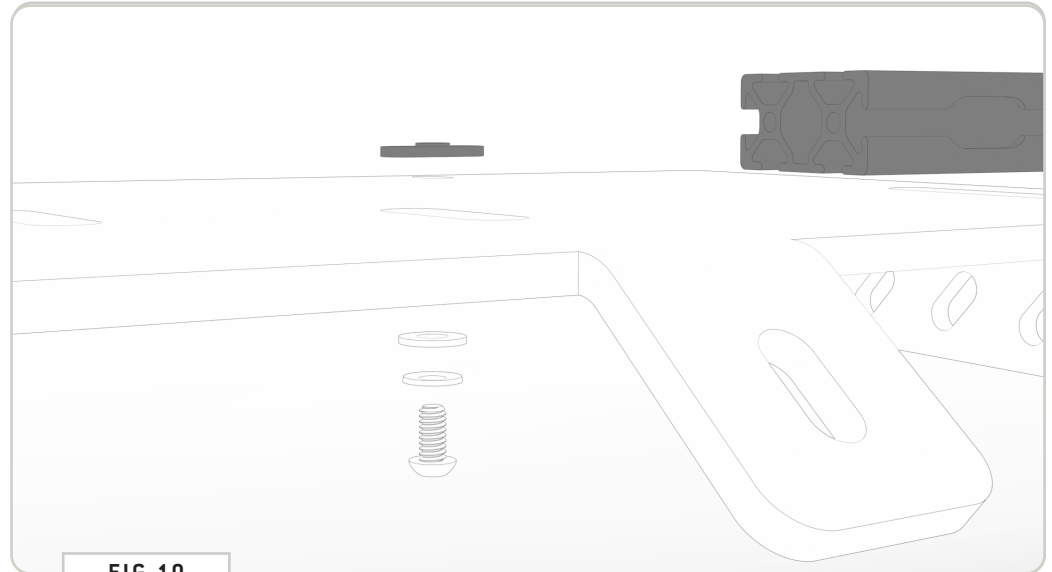

STEP | 04 FAIRING ASSEMBLY

4.3 Driver and Passenger Side Fairing Brackets: Attach the **Driver and Passenger Side Fairing Brackets** to the Assembly using **1/4-20 x 0.75 Flanged Button Head Screws, Flat Washers and Nylon Locknuts (FIG 12)**.

4.4 Fairing Gasket Trim: Attach the **Fairing Gasket Trim** to the **Front Fairing** in the orientation shown in **FIG 13**. Make sure the “bulbed” side is facing inward.

TOOLS REQUIRED FOR THIS STEP: + 3/16" ALLEN WRENCH
+ 7/16" WRENCH OR SOCKET

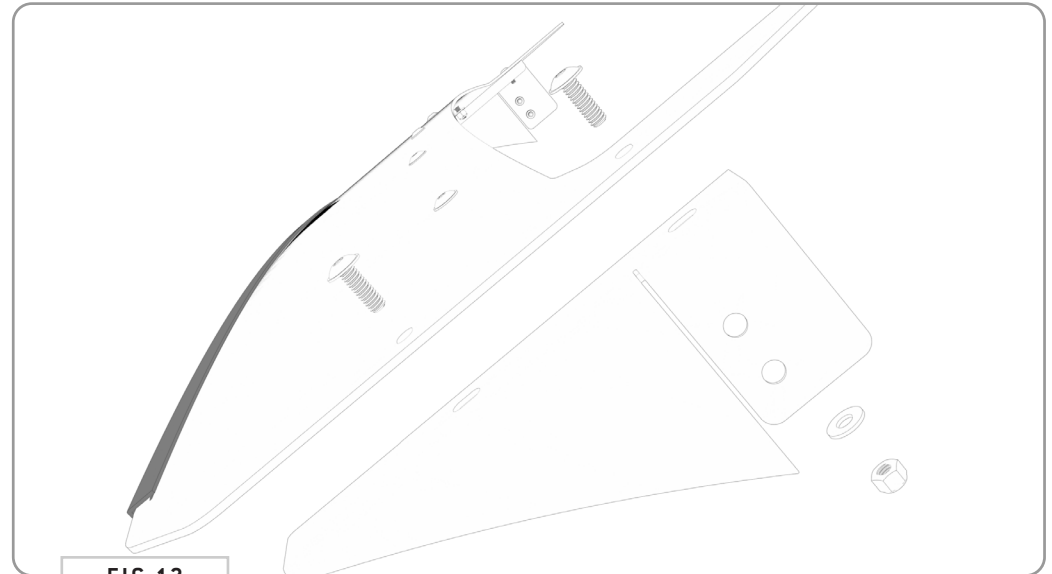

FIG 12

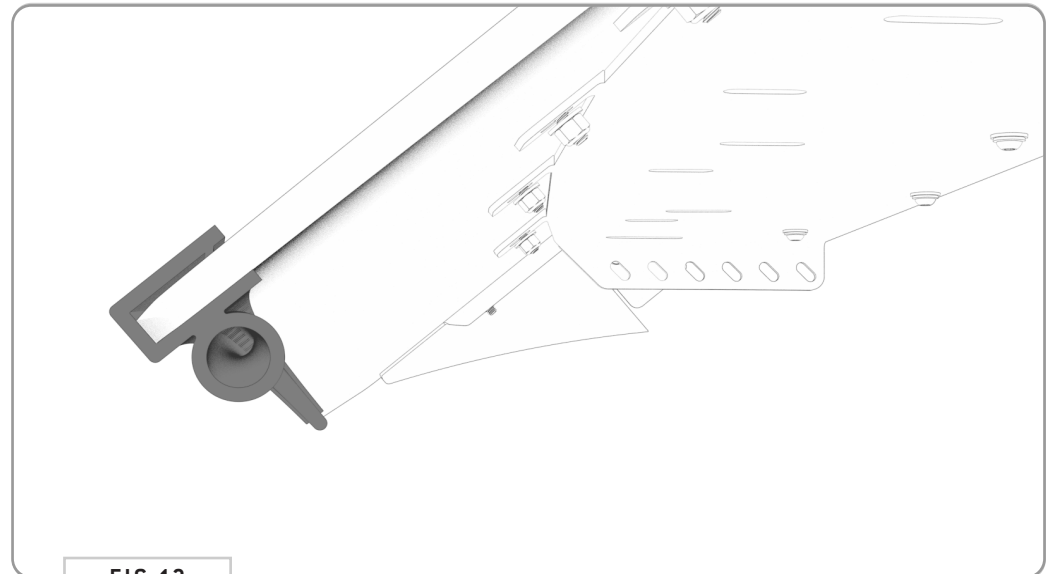

FIG 13

STEP | 04 FAIRING ASSEMBLY

4.5 Attach Front Fairing: Attach the Front Fairing to the Assembly using 1/4-20 x 0.75 Flanged Button Head Screws, Flat Washers and Nylon Locknuts (FIG 14+15).

TOOLS REQUIRED FOR THIS STEP: + 3/16" ALLEN WRENCH
+ 5/32" ALLEN WRENCH
+ 7/16" SOCKET OR WRENCH

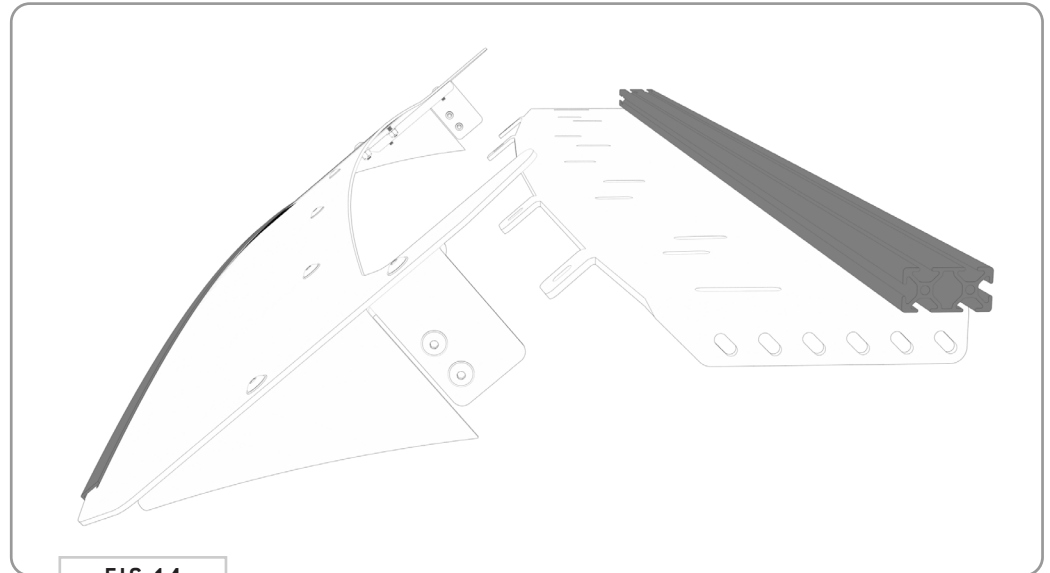

FIG 14

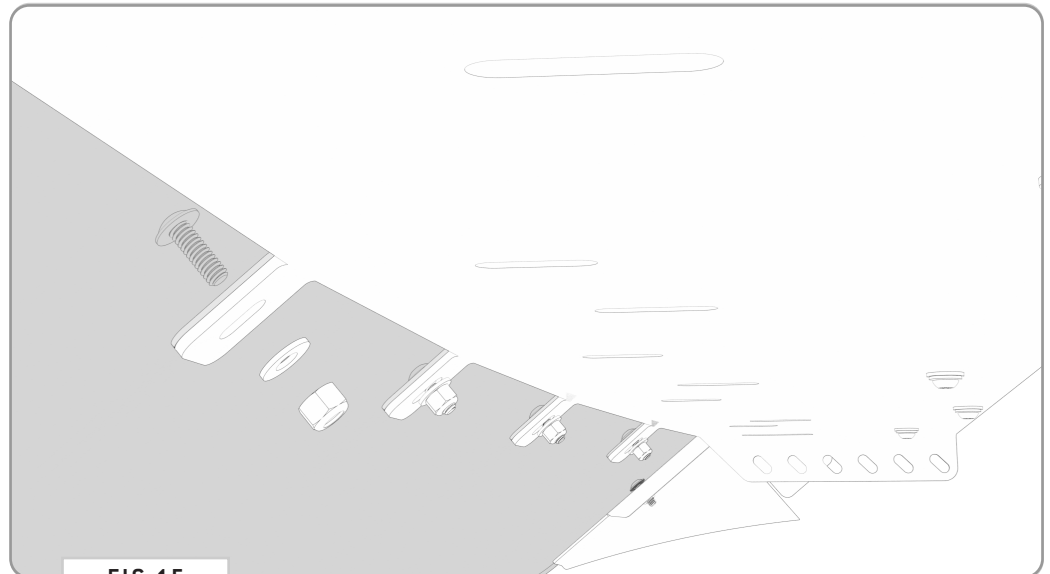

FIG 15

TOOLS REQUIRED FOR THIS STEP: + 3/16" ALLEN WRENCH

STEP | 05 FAIRING INSTALL

5.1 Fairing Install: Now you're ready to attach the fairing to the roof rack. Slide it in from the front and into the location shown in FIG 16. Tighten down using (8) 1/4-20" Flange Head Screws (FIG 17).

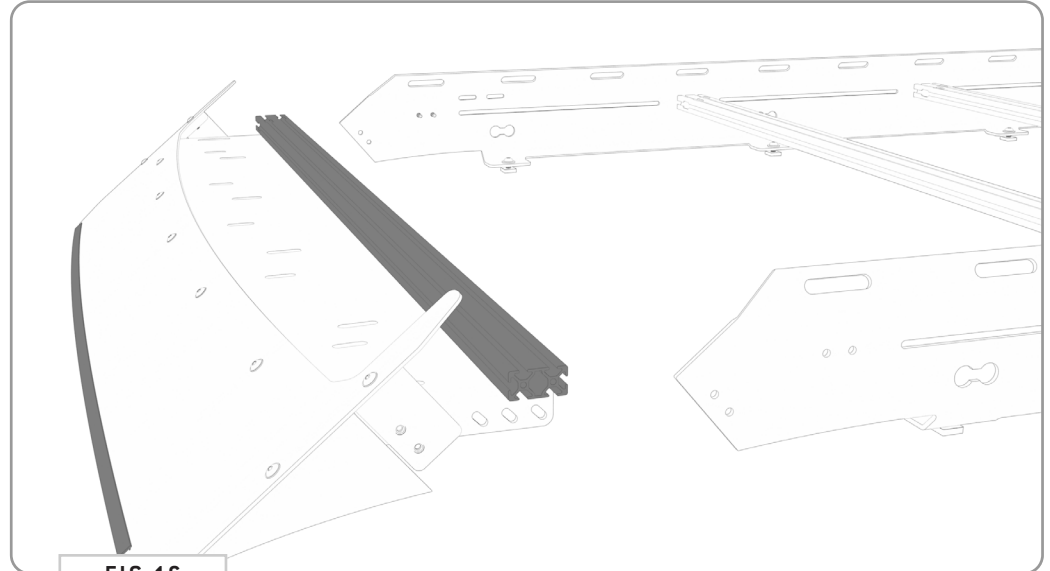

FIG 16

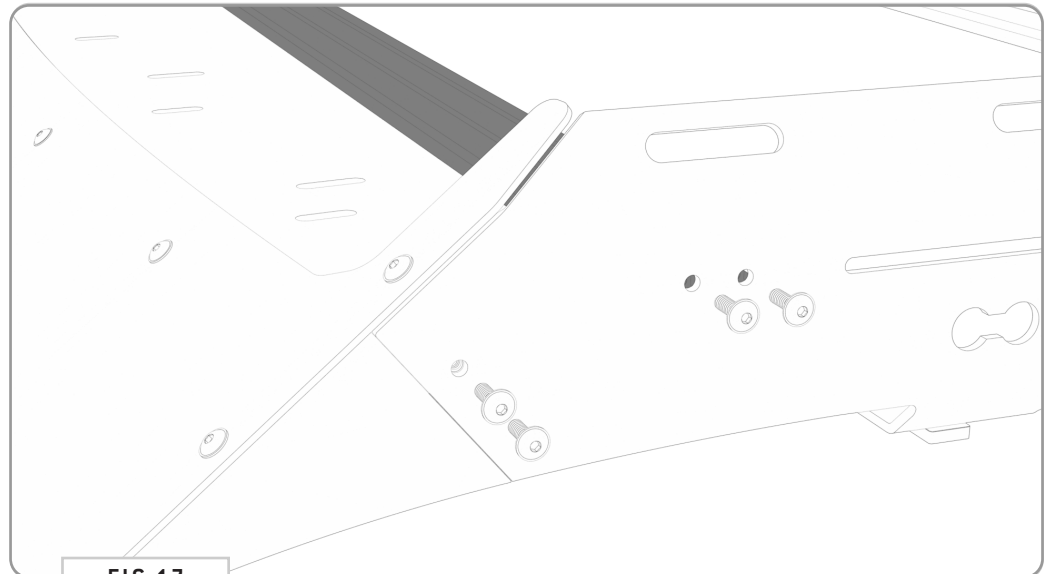

FIG 17

TOOLS REQUIRED FOR THIS STEP: + 3/16" ALLEN WRENCH
+ 5/32" ALLEN WRENCH

STEP | 06 REAR SPOILER INSTALL

6.1 Spoiler Assembly: Stack a 1/4-20" x 0.5 Button Head Screw, 1/4" Belleville Lock Washer and 1/4" Flat Washer as shown in FIG 18 and insert into the ten available top holes of the Rear Spoiler. Loosely assemble using a T-Nut. You'll only want to screw the T-Nuts on a little in order to provide clearance for the next step.

6.2 Crossbar Install: Now, slide the Crossbar onto the Rear Spoiler. You'll have to straighten each T-Nut as you go to get it to feed into the Crossbar correctly (FIG 19). After sliding the Rear Spoiler and Crossbar together, tighten all fasteners.

6.3 Fairing Install: Now you're ready to attach the Rear Spoiler to the roof rack. Slide it in from the back and into the location shown in FIG 20 and tighten down using (8) 1/4-20" Flange Head Screws.

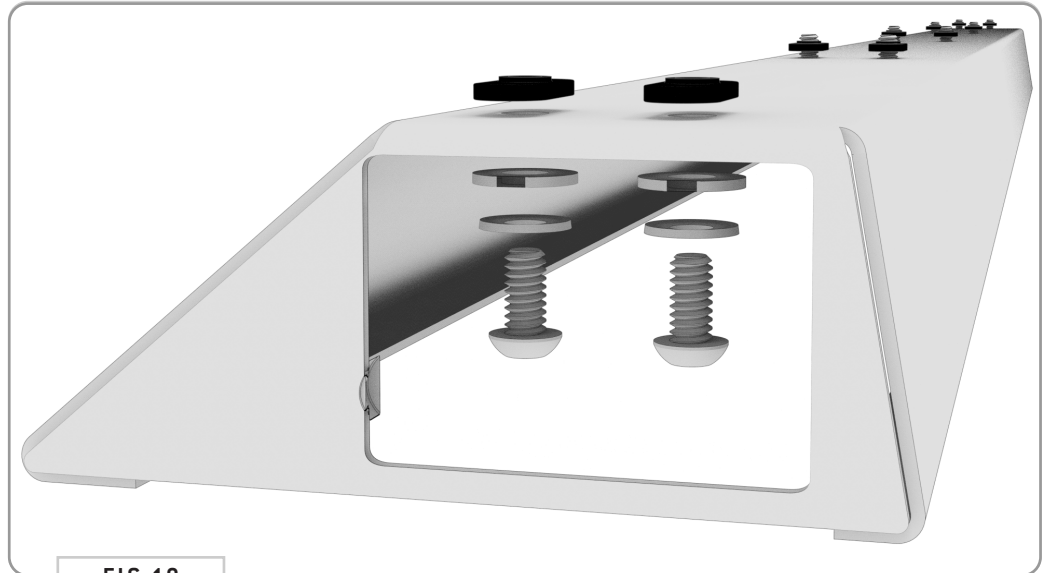

FIG 18

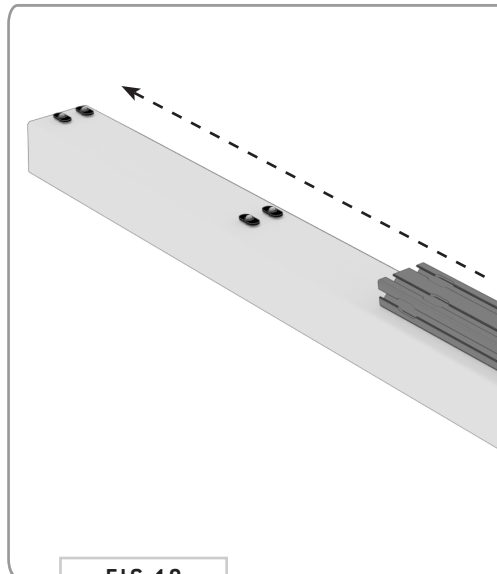

FIG 19

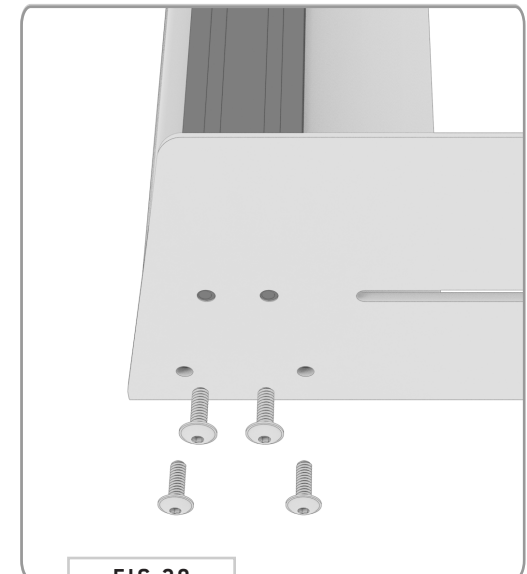

FIG 20

STEP | 07 FINAL ADJUSTMENTS

7.1 Tighten Crossbar Fasteners: Tighten all crossbar bolts using the 3/16" Allen Wrench.

NOTE - Do not overtighten! If you are concerned about the bolts backing out, you can put a dab of blue loctite on the bolts before tightening down completely.

7.2 Tighten Rail-to-Rail Fasteners: Now tighten Side Rails to Roof Rail using the 7/32" allen key.

7.3 Tighten Rail Connecting Plates: Tighten all Rail Connecting Plates using the 3/16" Allen Wrench and a 7/16" Socket.

TOOLS REQUIRED FOR THIS STEP: + 3/16" ALLEN WRENCH
+ 7/32" ALLEN WRENCH
+ 7/16" WRENCH OR SOCKET

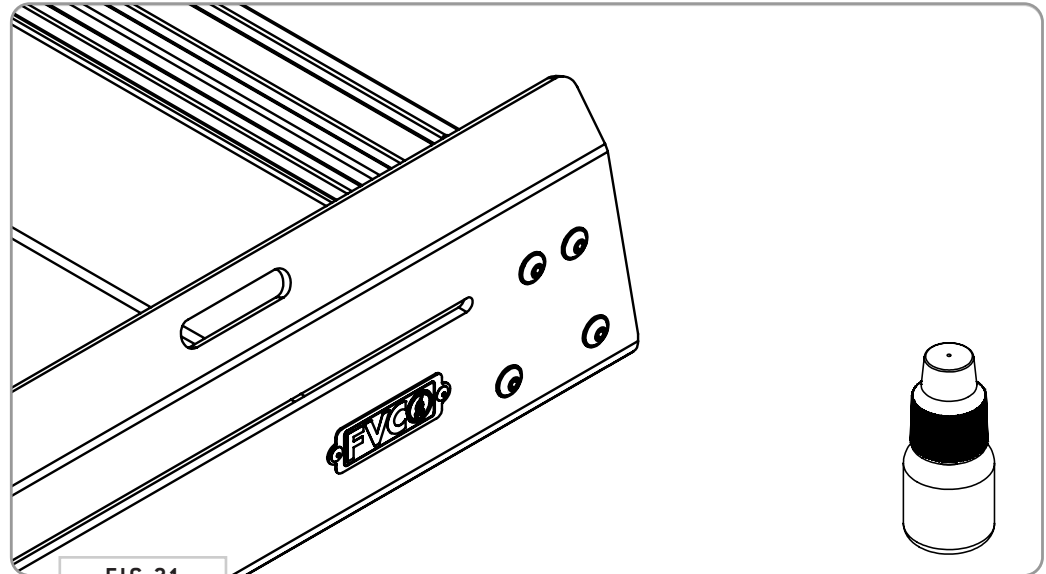

FIG 21

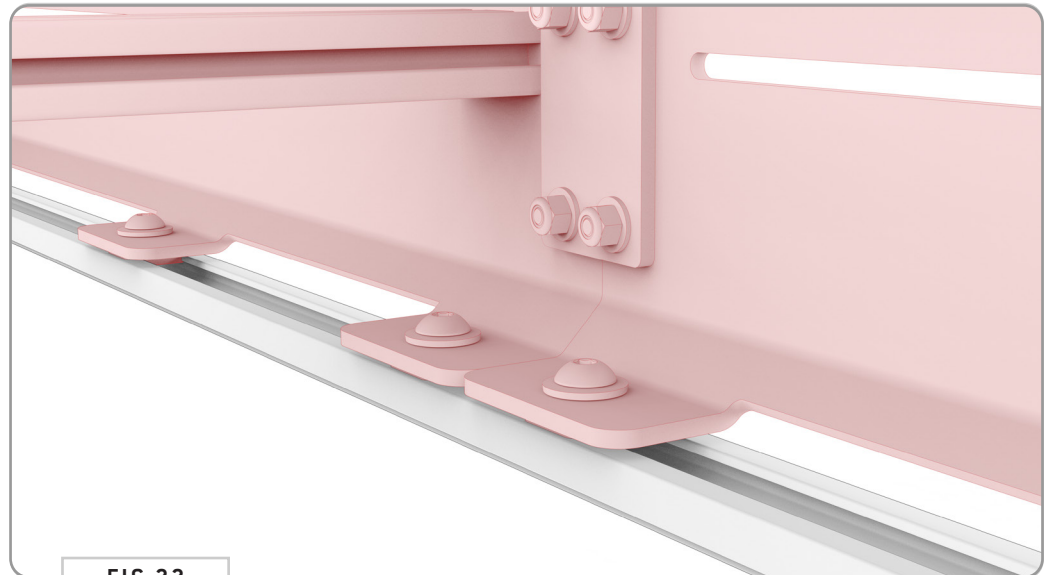

FIG 22

GET OUT AND EXPLORE!

+ LEAVE US A REVIEW

Happy with your new FVC product? We would love to hear (and see) from you! Head to the product page and click “Leave Review.” Add a short review and upload a few photos to be showcased on the product page.

+ SHARE YOUR PICS

We love seeing how our customers use their FVC products and following along with your adventures. Tag us in your photos with: @flatlinevanco or send them to us via email. We love posting customer pictures in our feed!

+ NEED ANY HELP?

If you are having any issues with your product, please reach out, and we will make it right. FVC is a company of van and outdoor enthusiasts that design and use our own products, so we want you to be as stoked on your new parts as we are!



@FLATLINEVANCO