



# INSTALLATION GUIDE

## SPRINTER VAN LOW PRO ROOF RACK - 170" + F80 KIT

SP0120B



### TOOLS REQUIRED (NOT INCLUDED)

- + MEASURING TAPE
- + 7/32" ALLEN WRENCH
- + 3/16" ALLEN WRENCH
- + 5/32" ALLEN WRENCH

### INSTALL INFO

TIME TO INSTALL THIS PRODUCT: 1-2 HOURS

Additional help is suggested for a few of the install steps.

### BEFORE YOU START

Please inspect the product and packaging upon delivery to ensure there are no issues and that all parts and hardware are accounted for.

Contact us ASAP if anything is missing at:  
[support@flatlinevanco.com](mailto:support@flatlinevanco.com)

# BEFORE YOU START

All Flatline Van Co products must be properly assembled and secured before attaching to your vehicle. Improper attachment could result in an automobile accident, and could cause serious bodily injury or death to you or to others involved. You are responsible for assembling and securing Flatline Van Co products to your vehicle, checking the mounting points and attachments prior to use, and regularly inspecting the products for wear and or damage. We always recommend you use a professional to install any aftermarket accessories to your vehicle. If you have no mechanical experience and are not thoroughly familiar with the installation procedures, you must have the product installed by a professional installer or other qualified persons. The responsibility is yours and must be taken seriously for everyone's safety.



# PACKAGE CONTENTS

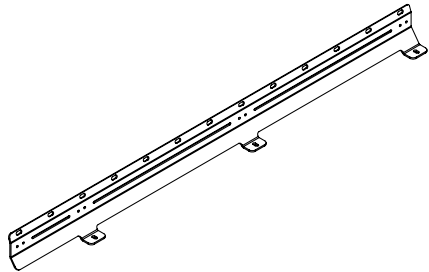

DRIVER FRONT SIDE RAIL

QTY: 1

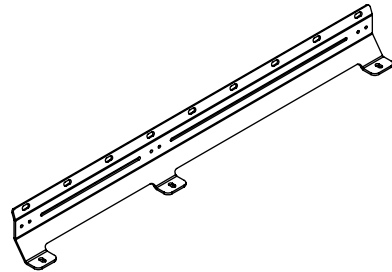

DRIVER CENTER SIDE RAIL

QTY: 1

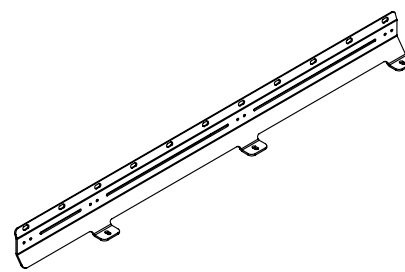

DRIVER REAR SIDE RAIL

QTY: 1

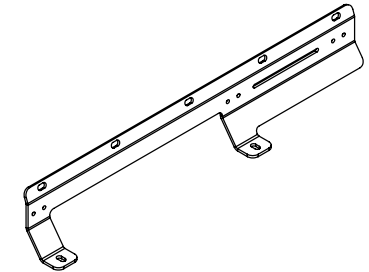

PASSENGER FRONT SIDE RAIL

QTY: 1

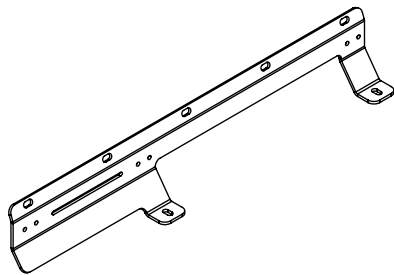

PASSENGER REAR SIDE RAIL

QTY: 1

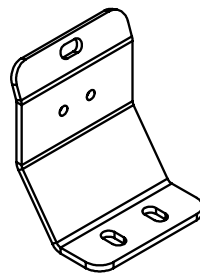

CENTER SIDE RAIL

QTY: 6

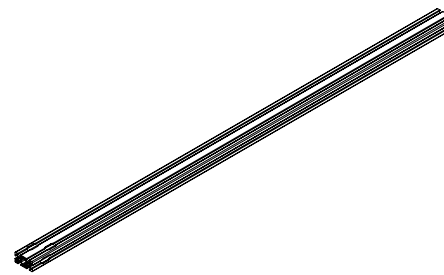

CROSSBAR

QTY: 8

# HARDWARE

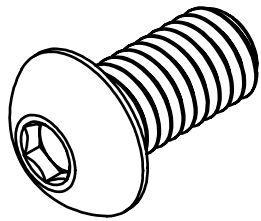

3/8-16 X 0.75 BUTTON  
HEAD HEX DRIVE  
SCREW

QTY: 28

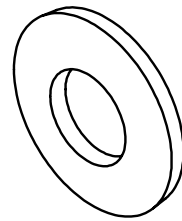

3/8 SCREW BELLEVILLE  
SPRING LOCK  
WASHER

QTY: 28

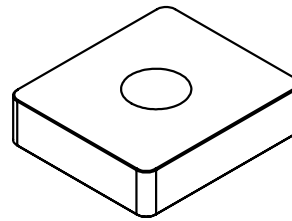

SPRINTER RAIL NUT

QTY: 28

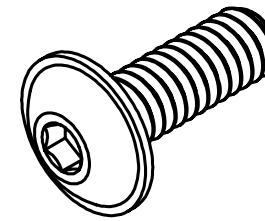

1/4-20 X 0.75  
FLANGED BUTTON  
HEAD HEX DRIVE  
SCREW

QTY: 32

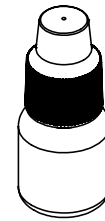

THREADLOCKER

QTY: 1

TOOLS REQUIRED FOR THIS STEP: + MEASURING TAPE

## STEP | 01 LAYOUT AND INSTALL PREP

**1.1 Install Rail Nuts:** Slide (10) ten of the Rail Nuts into the passenger side factory roof rail, and (6) six into the driver side rail (FIG 1).

**PRO-TIP:** *If you're installing a side ladder, put two (2) extra rail nuts in on the driver side (FIG 2).*

**1.2 Layout Rail Nuts (Driver's Side):** Space out the Rail Nuts close to their final positions as roughly laid out in FIG 3.

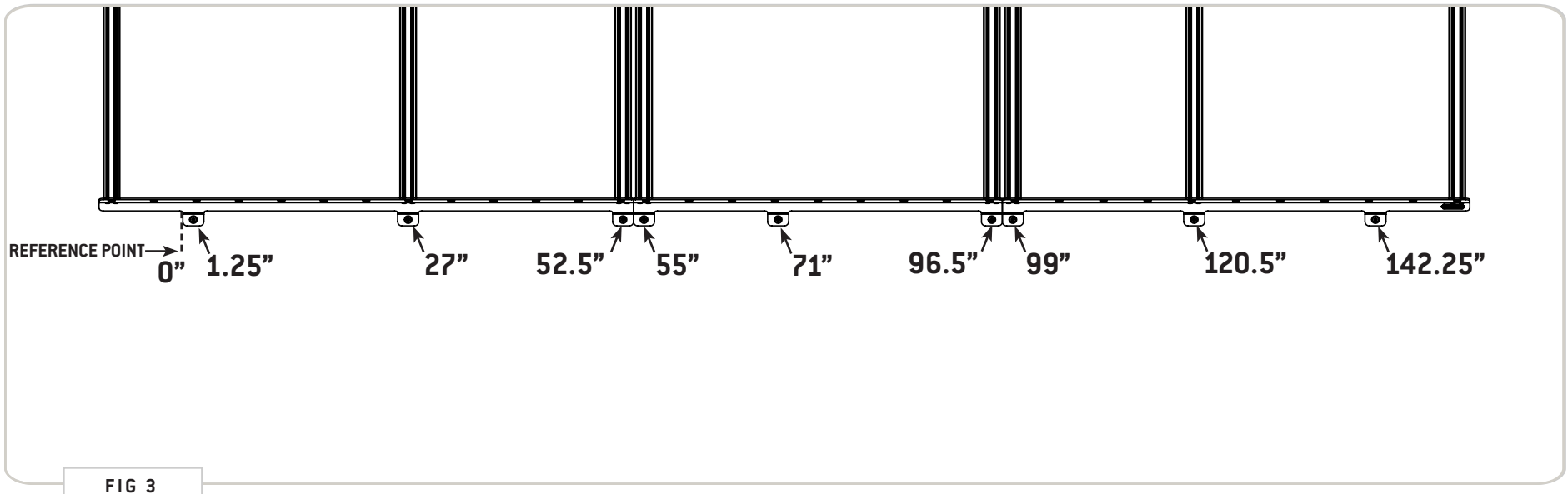
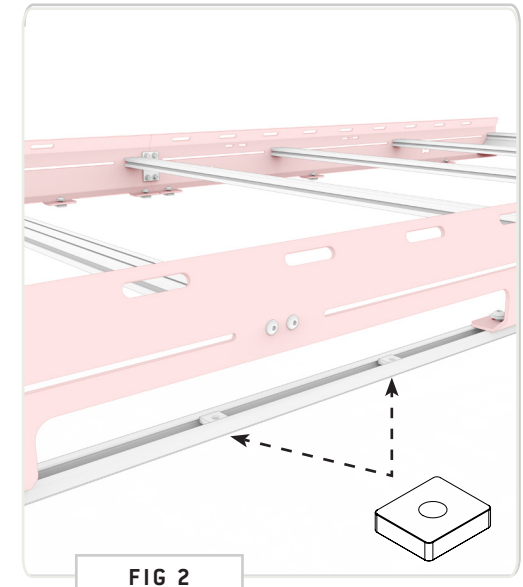
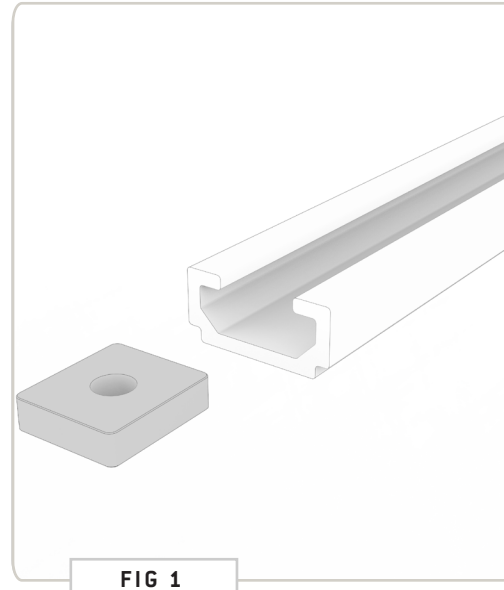

TOOLS REQUIRED FOR THIS STEP: + 7/32" ALLEN WRENCH

## STEP | 02 SIDE RAIL INSTALL

**2.1 Install Side Rails:** Beginning with the forward section of the rack (see FIG 5 for layout), start loosely attaching the side rails to the roof rails using the **3/8-16" Button Head Screws & 3/8" Lock Washers**, but do not tighten them all the way down (FIG 4).

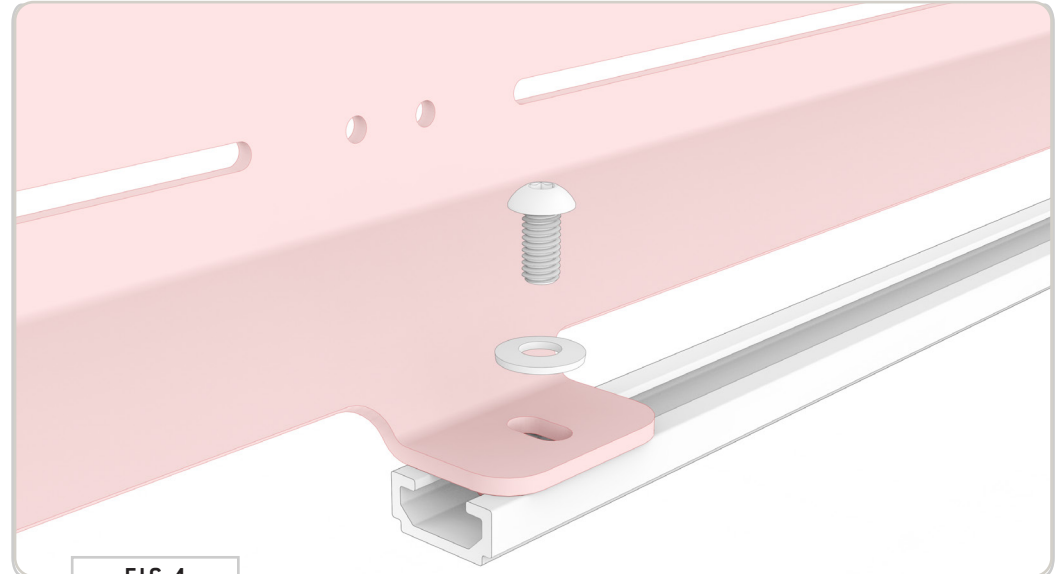

FIG 4

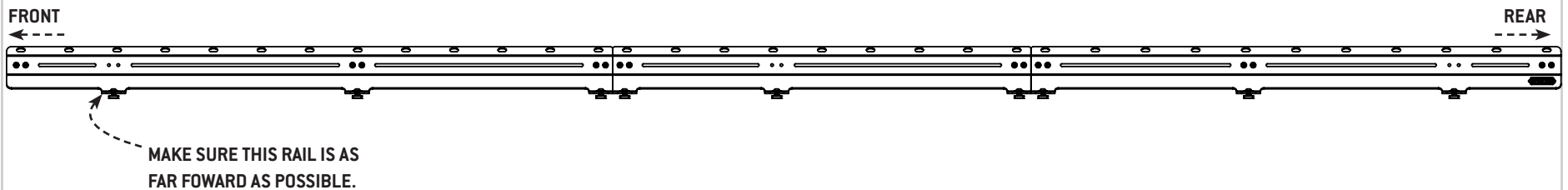

FIG 5

TOOLS REQUIRED FOR THIS STEP: + 7/32" ALLEN WRENCH

## STEP | 02 SIDE RAIL INSTALL

**2.2 Install Front and Rear F80 Brackets:** Next, find your **Front And Rear F80 Brackets** and Align them with the corresponding rails of the **Driver's Side** (FIG 6).

**2.3 Install Center F80 Brackets:** Grab your Center Brackets and space them out in between the front and rear brackets. FIG 6 and 7 depict an example layout of F80 brackets with the low pro roof rack. Loosely attach to the roof rails using the **3/8-16" Button Head Screws & 3/8" Lock Washers**.

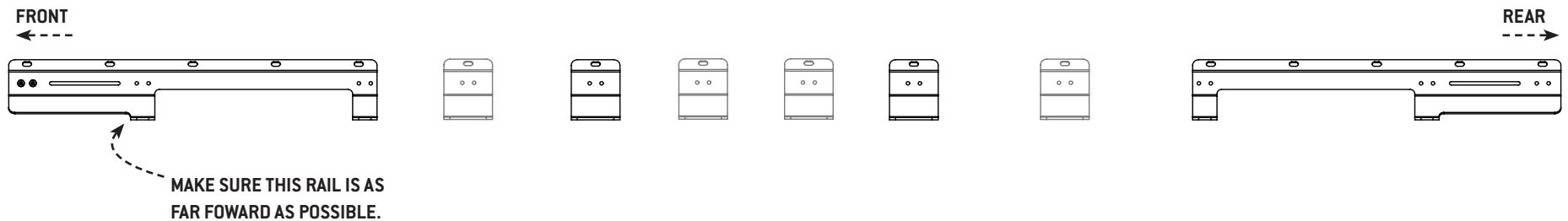
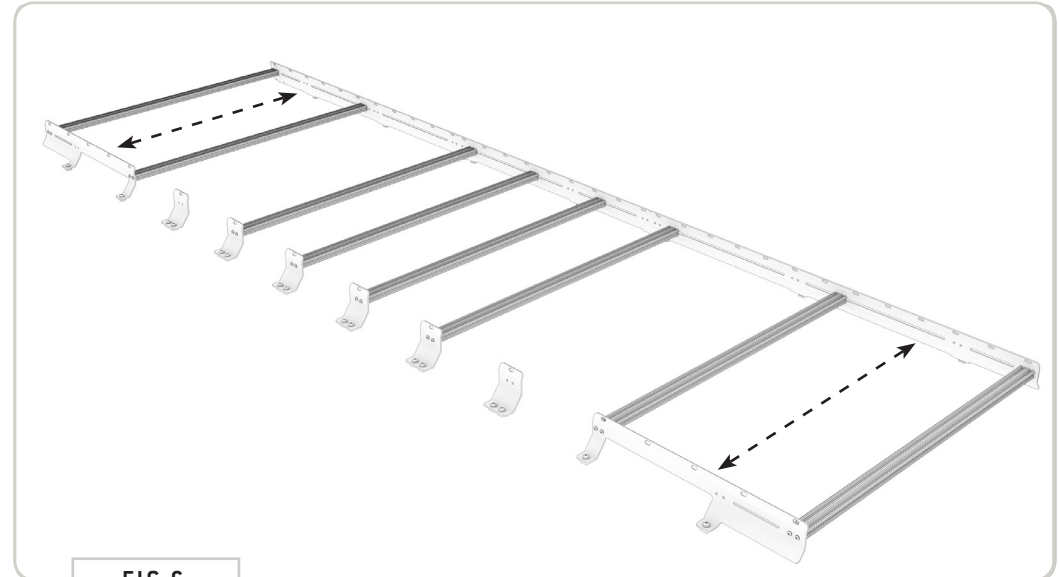

TOOLS REQUIRED FOR THIS STEP: + 3/16" ALLEN WRENCH

## STEP | 03 CROSSBAR INSTALL

**3.1 Layout Crossbar Locations:** Position the crossbars in your desired locations, loosely threading in the **1/4-20" Flange Head Screws** to hold in place (**FIG 7**).

**NOTE** - If purchased with a front fairing, save a crossbar for Fairing Assembly in the next step. Proceed to Step 5 if purchased without.

**NOTE** - Keep in mind the layout of your roof top array (solar panels, fans, tents, etc.) You can mount crossbars in the set pair of holes (**FIG 8**), or you can place them in the slots which provides you more freedom of layout.

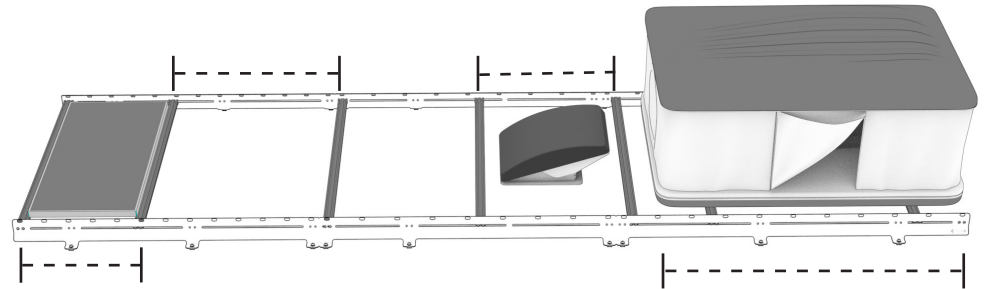

FIG 7

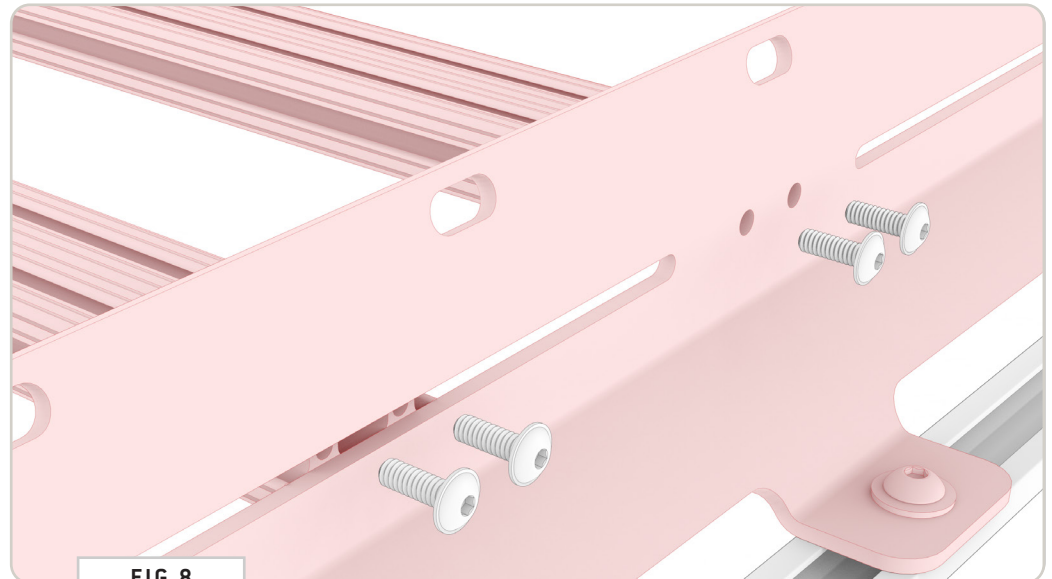

FIG 8



**TOOLS REQUIRED FOR THIS STEP:** + 5/32" ALLEN WRENCH  
 + 3/16" ALLEN WRENCH

## STEP | 04 FAIRING INSTALL

**4.1 Fairing Assembly:** Insert the hardware as shown in FIG 9 into the available slots in the fairing. You'll only want to screw the t-nuts on a little in order to provide clearance for the next step.

**4.2 Crossbar Install:** Now, slide the crossbar onto the fairing. You'll have to straighten each t-nut as you go to get it to feed into the crossbar correctly (FIG 10). After sliding the fairing and crossbar together, tighten all five (5) of the 1/4-20" Button Head Screws.

**4.3 Fairing Install:** Now you're ready to attach the fairing to the roof rack. Slide it in from the front and into the location shown in FIG 9 and tighten down using (2) 1/4-20" Flange Head Screws.

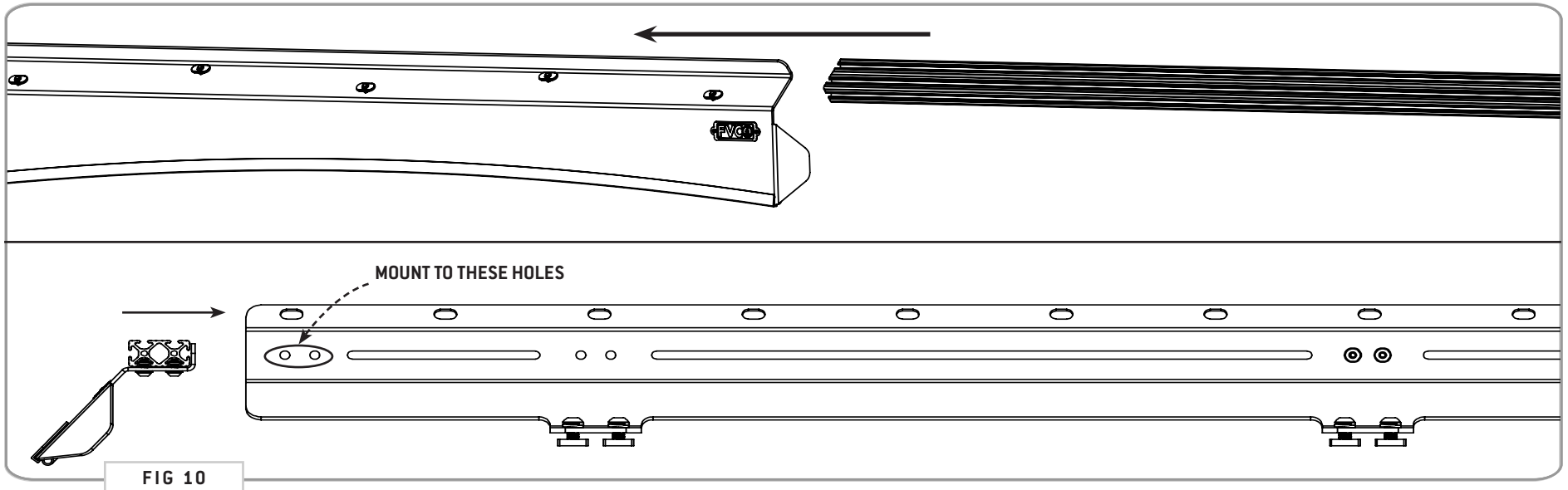
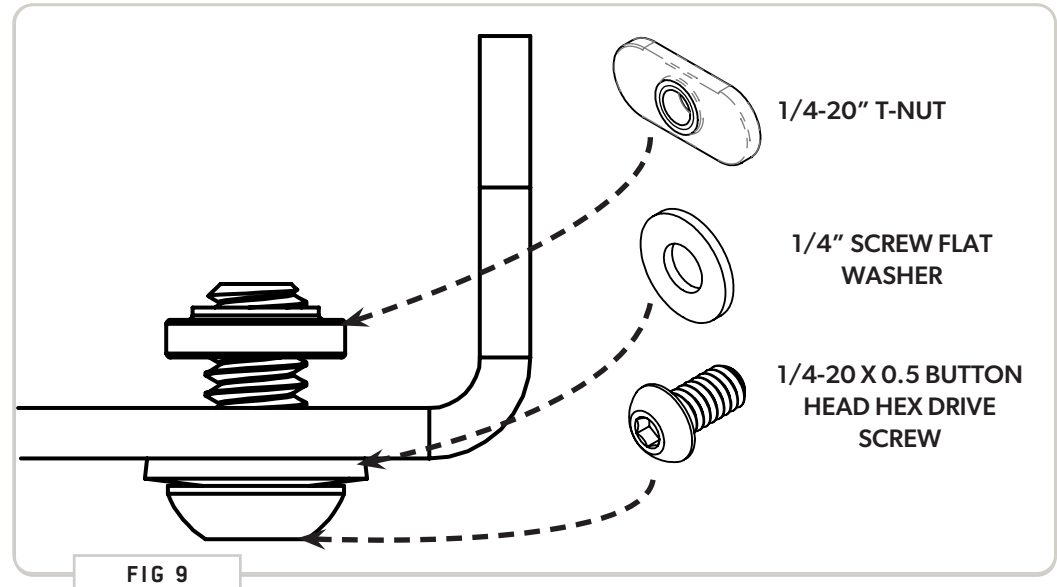

## STEP | 05 FINAL ADJUSTMENTS

**5.1 Tighten Crossbar Fasteners:** Tighten all crossbar bolts using the 3/16" Allen Wrench.

**NOTE - Do not overtighten!** If you are concerned about the bolts backing out, you can put a dab of blue loctite on the bolts before tightening down completely.

**5.2 Tighten Rail-to-Rail Fasteners:** Now tighten Side Rails to Roof Rail using the 7/32" allen key.

**TOOLS REQUIRED FOR THIS STEP:** + 3/16" ALLEN WRENCH  
+ 7/16" WRENCH OR SOCKET

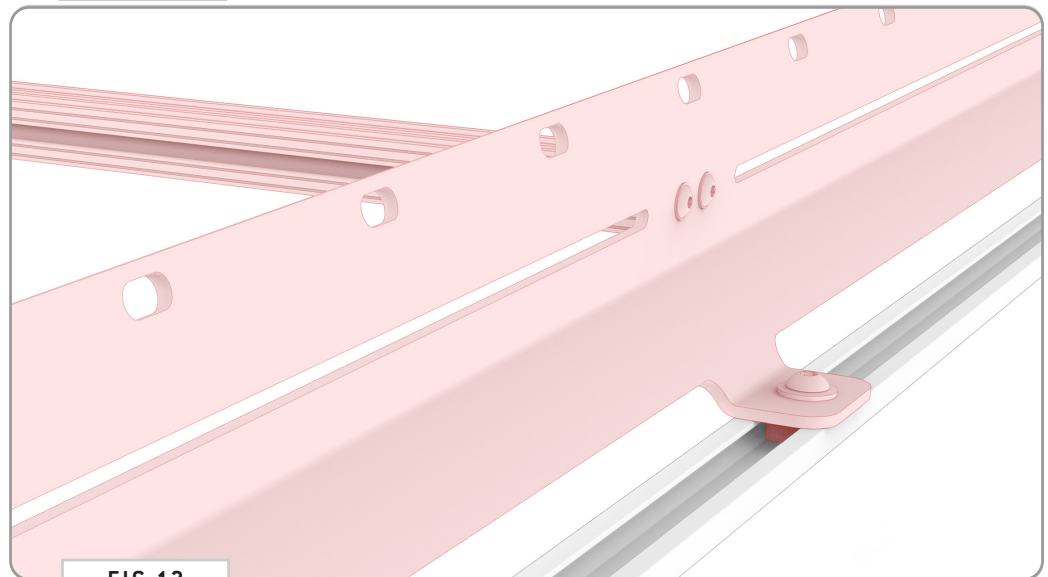
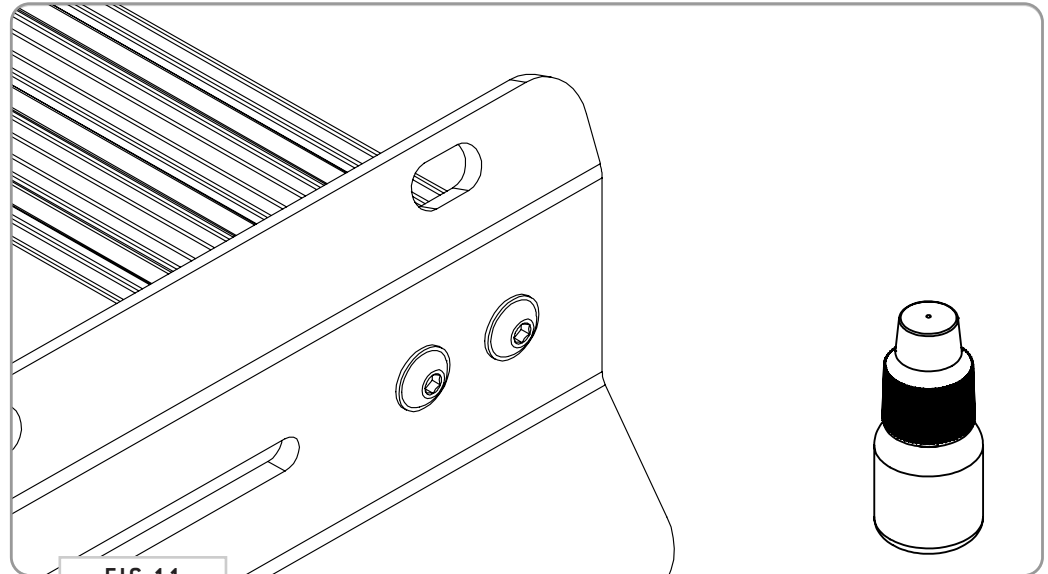

# GET OUT AND EXPLORE!

## + LEAVE US A REVIEW

---

Happy with your new FVC product? We would love to hear (and see) from you! Head to the product page and click "Leave Review." Add a short review and upload a few photos to be showcased on the product page.

## + SHARE YOUR PICS

---

We love seeing how our customers use their FVC products and following along with your adventures. Tag us in your photos with: @flatlinevanco or send them to us via email. We love posting customer pictures in our feed!

## + NEED ANY HELP?

---

If you are having any issues with your product, please reach out, and we will make it right. FVC is a company of van and outdoor enthusiasts that design and use our own products, so we want you to be as stoked on your new parts as we are!



@FLATLINEVANCO