



## Installation Guide



## Low Pro Front Fairing LR SP0116B

All Flatline Van Co products must be properly assembled and secured before attaching to your vehicle. Improper attachment could result in an automobile accident, and could cause serious bodily injury or death to you or to others involved. You are responsible for assembling and securing Flatline Van Co products to your vehicle, checking the mounting points and attachments prior to use, and regularly inspecting the products for wear and or damage. We always recommend you use a professional to install any aftermarket accessories to your vehicle. If you have no mechanical experience and are not thoroughly familiar with the installation procedures, you must have the product installed by a professional installer or other qualified persons. The responsibility is yours and must be taken seriously for everyone's safety.



thanks.

# THANK YOU!

ARE YOU EXCITED ABOUT YOUR NEW LOW PRO ROOF RACK AND FAIRING? HERE ARE A FEW THINGS TO DO BEFORE BEGINNING THE INSTALLATION PROCESS--

- PLEASE INSPECT THE PRODUCT TO ENSURE THERE WAS NO DAMAGE INCURRED DURING SHIPPING.
- IF THERE IS DAMAGE TO REPORT, PLEASE CONTACT OUR CUSTOMER SERVICE DEPARTMENT AS SOON AS POSSIBLE.
- NEXT, USING THE "PACKAGE CONTENTS" PAGE, CHECK INVENTORY AND FAMILIARIZE YOURSELF WITH THE PARTS AND HARDWARE.
- GATHER ALL TOOLS REQUIRED FOR INSTALL.  
-5/32 HEX KEY ALLEN WRENCH

ESTIMATED INSTALL TIME- 30-45 MIN.

## TOOLS



5/32 ALLEN KEY

# PACKAGE CONTENTS

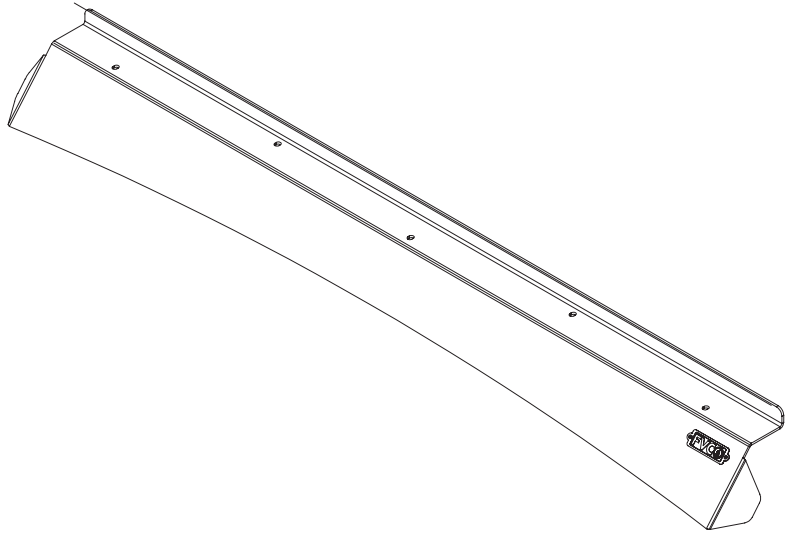

**FAIRING**  
**QTY - 1**

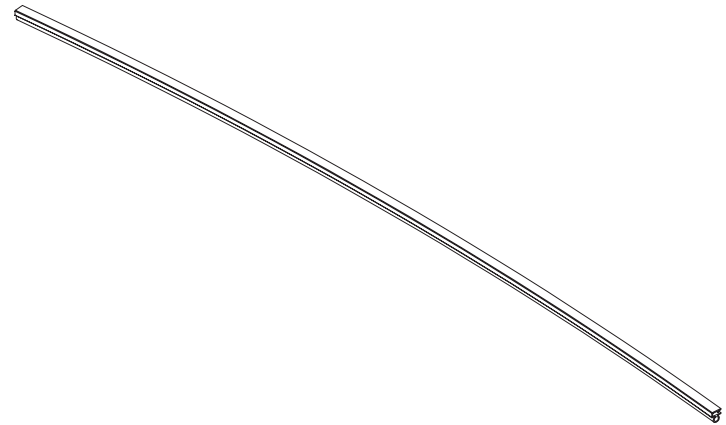

**FAIRING GASKET**  
**QTY - 1**

# HARDWARE

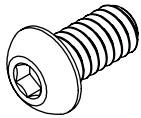

1/4-20 X 0.5 BUTTON HEAD  
HEX DRIVE SCREW

QTY - 5

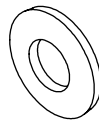

1/4 SCREW BELLEVILLE  
SPRING LOCK WASHER

QTY - 5

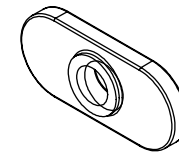

1/4-20 ECONOMY T-NUT

QTY - 5

# LET'S GET STARTED!

- 1. IF YOU HAVE ALREADY INSTALLED YOUR LOW PRO ROOF RACK, REMOVE THE FRONT CROSSBAR FROM THE RACK BEFORE BEGINNING.
- 2. TAKE THE FRONT FAIRING AND THE FAIRING GASKET AND PRESS THE GASKET ONTO THE BOTTOM EDGE OF THE FAIRING WITH THE BULB SIDE FACING IN SO IT WILL REST ON THE VAN ROOF WHEN INSTALLED.

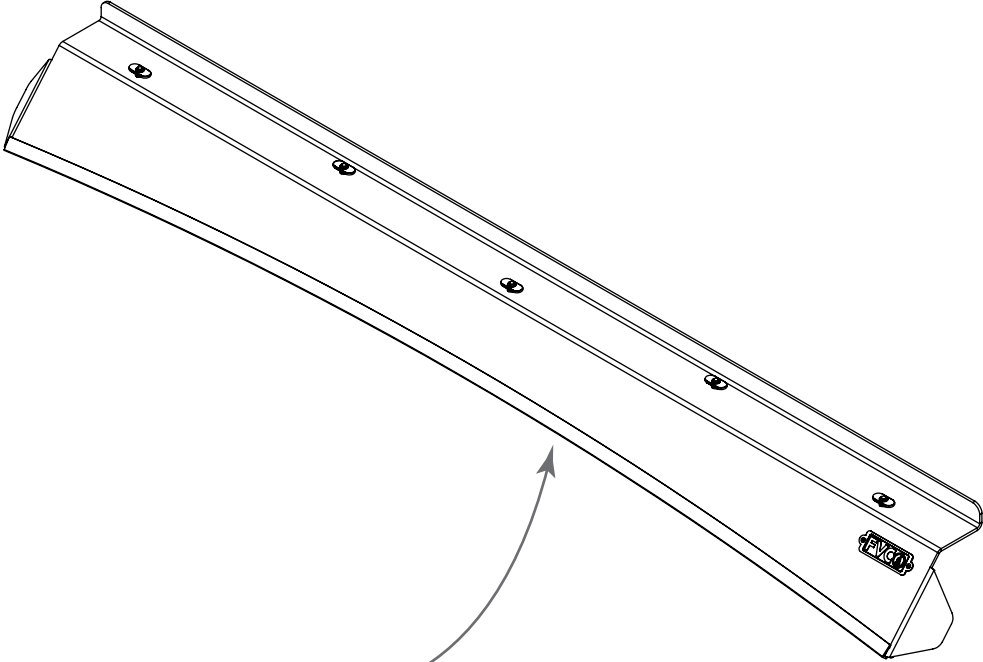

FAIRING GASKET

FIGURE 1

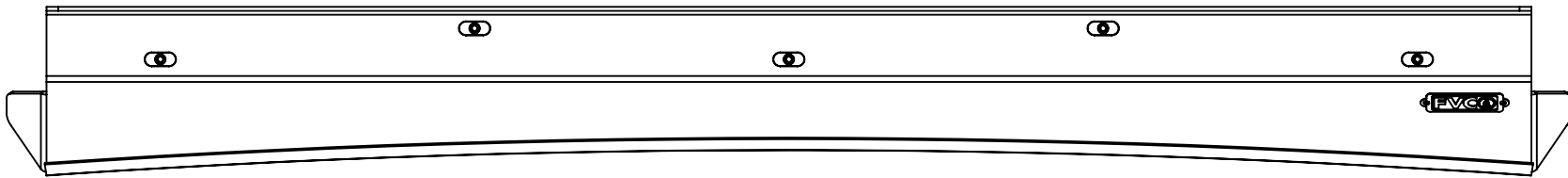
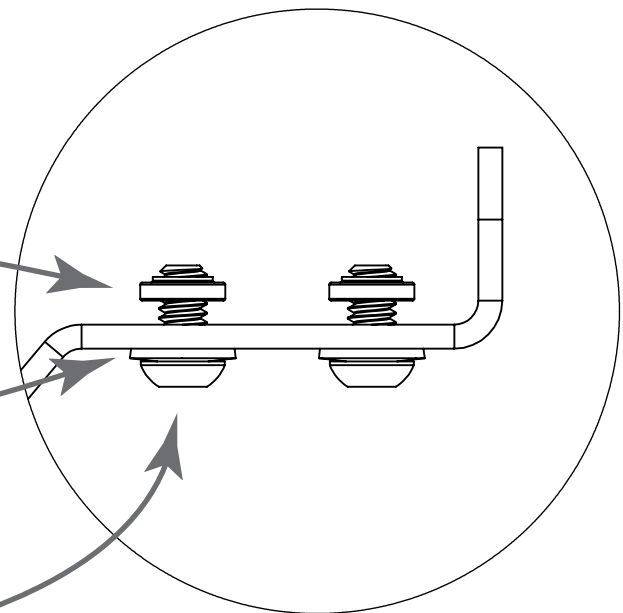

FIGURE 2



3. NEXT, INSERT THE HARDWARE INTO THE FAIRING AS SHOWN. YOU ONLY WANT TO SCREW THE T-NUTS ON A LITTLE TO PROVIDE CLEARANCE FOR THE NEXT STEP.

-   
1/4-20 ECONOMY T-NUT
-   
1/4 SCREW BELLEVILLE  
SPRING LOCK WASHER
-   
1/4-20 X 0.5 BUTTON HEAD  
HEX DRIVE SCREW



3. NOW, SLIDE THE CROSSBAR ONTO THE FAIRING. YOU'LL HAVE TO STRAIGHTEN EACH T NUT AS YOU GO TO GET IT TO FEED INTO THE CROSSBAR CORRECTLY. (SEE **FIGURE 3**)

**FIGURE 3**

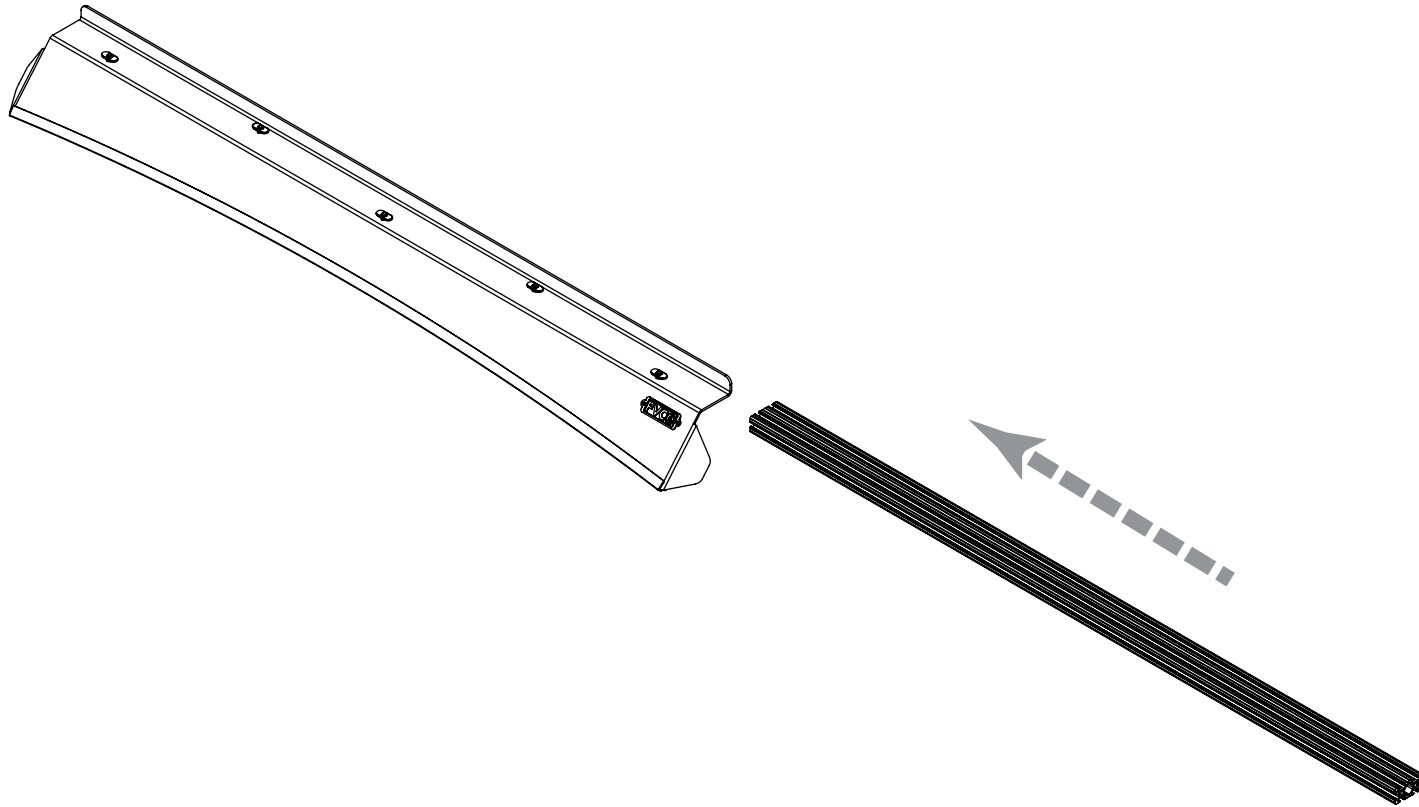



4. AFTER SLIDING THE FAIRING AND CROSSBAR TOGETHER, TIGHTEN ALL FIVE (5) OF THE 1/4-20 BUTTON HEAD SCREWS.
5. NOW YOU'RE READY TO ATTACH THE FAIRING TO THE ROOF RACK. SLIDE IT IN FROM THE FRONT, THE CROSSBAR WILL ATTACH IN THE SAME PLACE IT WAS REMOVED FROM ON THE VERY FRONT OF THE SIDE RAILS AND TIGHTEN DOWN USING THE PREVIOUSLY REMOVED 1/4-20 FLANGE HEAD SCREWS (FIGURE 4)

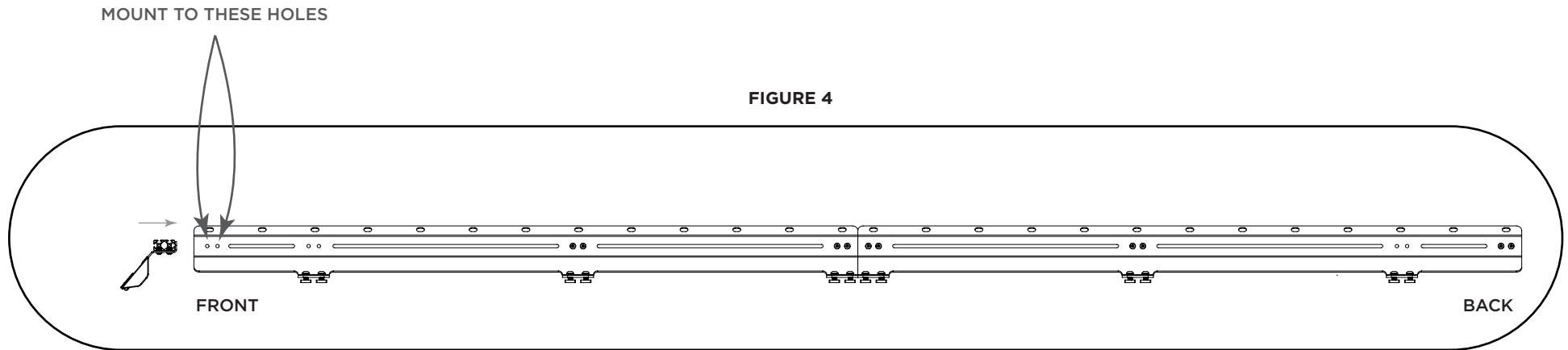

# GET OUT AND EXPLORE!

## LEAVE US A REVIEW

Happy with your new FVC product? We would love to hear (and see) from you! Head to the product page and click "Leave Review." Add a short review and upload a few photos to be showcased on the product page.

## SHARE YOUR PHOTOS WITH US

We love seeing how our customers use their FVC products and following along with your adventures. Tag us in your photos with @flatlinevanco or send them to us via email. We love posting customer pictures in our feed!

## CUSTOMER SUPPORT

If you are having any issues with your product, please reach out, and we will make it right. FVC is a company of van and outdoor enthusiasts that design and use our own products, so we want you to be as stoked on your new parts as we are!



**@flatlinevanco**



**facebook.com/flatlinevanco**



**youtube.com/c/flatlinevanco**



**support@flatlinevanco.com**



**thanks!**