

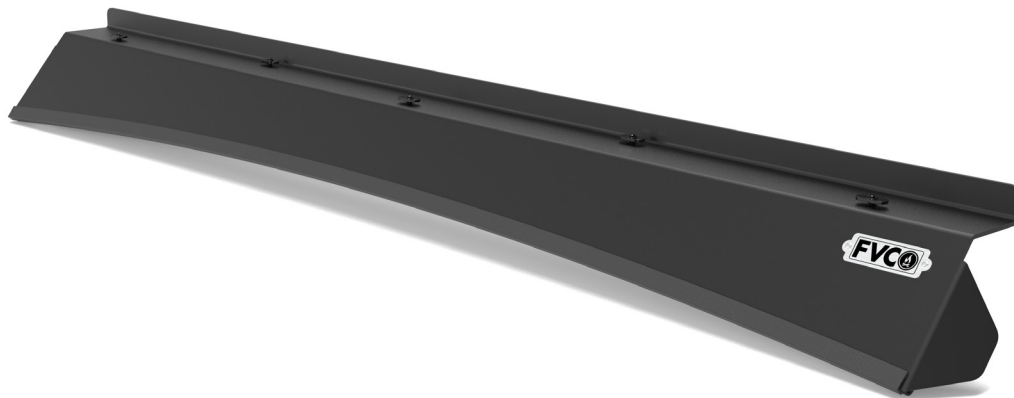

# INSTALLATION GUIDE

## SPRINTER VAN LOW PRO FRONT FAIRING - HIGH ROOF

SP0111B



### TOOLS REQUIRED (NOT INCLUDED)

- + 3/16" ALLEN WRENCH
- + 5/32" ALLEN WRENCH

### INSTALL INFO

TIME TO INSTALL THIS PRODUCT: 45 MINUTES

Additional help is suggested for a few of the install steps.

### BEFORE YOU START

Please inspect the product and packaging upon delivery to ensure there are no issues and that all parts and hardware are accounted for.

Contact us ASAP if anything is missing at:  
[support@flatlinevanco.com](mailto:support@flatlinevanco.com)

# BEFORE YOU START

All Flatline Van Co products must be properly assembled and secured before attaching to your vehicle. Improper attachment could result in an automobile accident, and could cause serious bodily injury or death to you or to others involved. You are responsible for assembling and securing Flatline Van Co products to your vehicle, checking the mounting points and attachments prior to use, and regularly inspecting the products for wear and or damage. We always recommend you use a professional to install any aftermarket accessories to your vehicle. If you have no mechanical experience and are not thoroughly familiar with the installation procedures, you must have the product installed by a professional installer or other qualified persons. The responsibility is yours and must be taken seriously for everyone's safety.



# PACKAGE CONTENTS

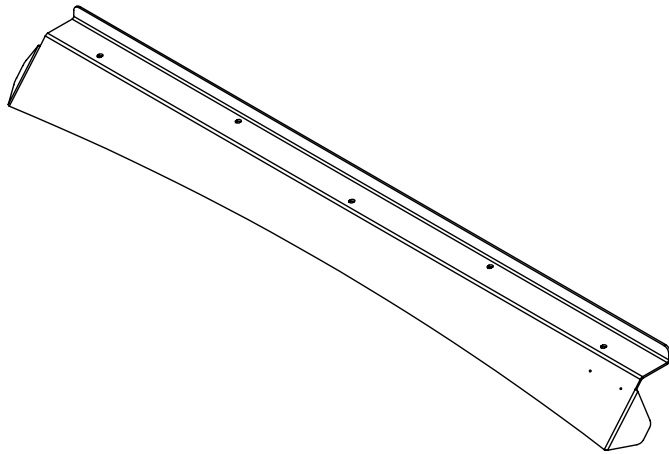

SPRINTER FRONT FAIRING

QTY: 1

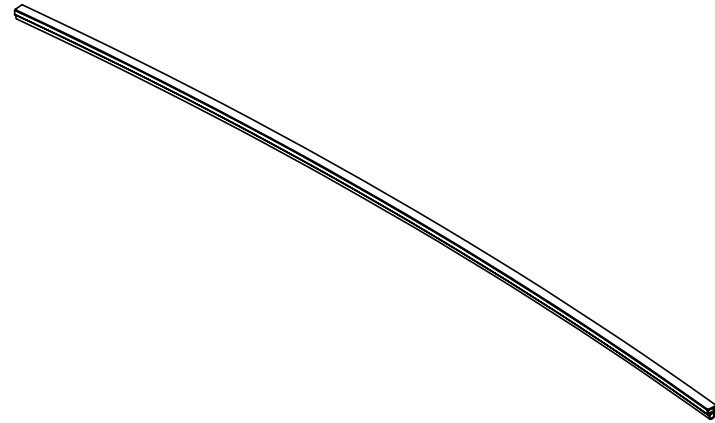

FAIRING GASKET

QTY: 1

# HARDWARE

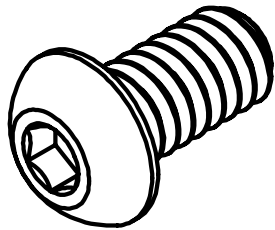

1/4-20 X 0.5 BUTTON HEAD  
HEX DRIVE SCREW

QTY: 5

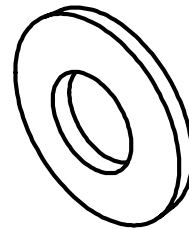

1/4 SCREW BELLEVILLE  
SPRING LOCK WASHER

QTY: 5

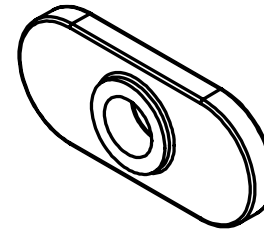

1/4-20 ECONOMY T-NUT

QTY: 5

**TOOLS REQUIRED FOR THIS STEP:** + 5/32" ALLEN WRENCH  
+ 3/16" ALLEN WRENCH

## STEP | 01 FAIRING ASSEMBLY

**1.1 Prepare Crossbar:** if you have already installed your low pro roof rack, remove the front crossbar from the rack before beginning.

**1.2 Fairing Assembly:** Insert the hardware as shown in FIG 1 into the available slots in the fairing. You'll only want to screw the t-nuts on a little in order to provide clearance for the next step.

**1.3 Gasket Install:** Attach the **Fairing Gasket** to the **Fairing** in the orientation as shown in FIG 2. Firmly press on the **Gasket** with your hand or a mallet until it "seats" itself into place along the front edge of the **Fairing**.

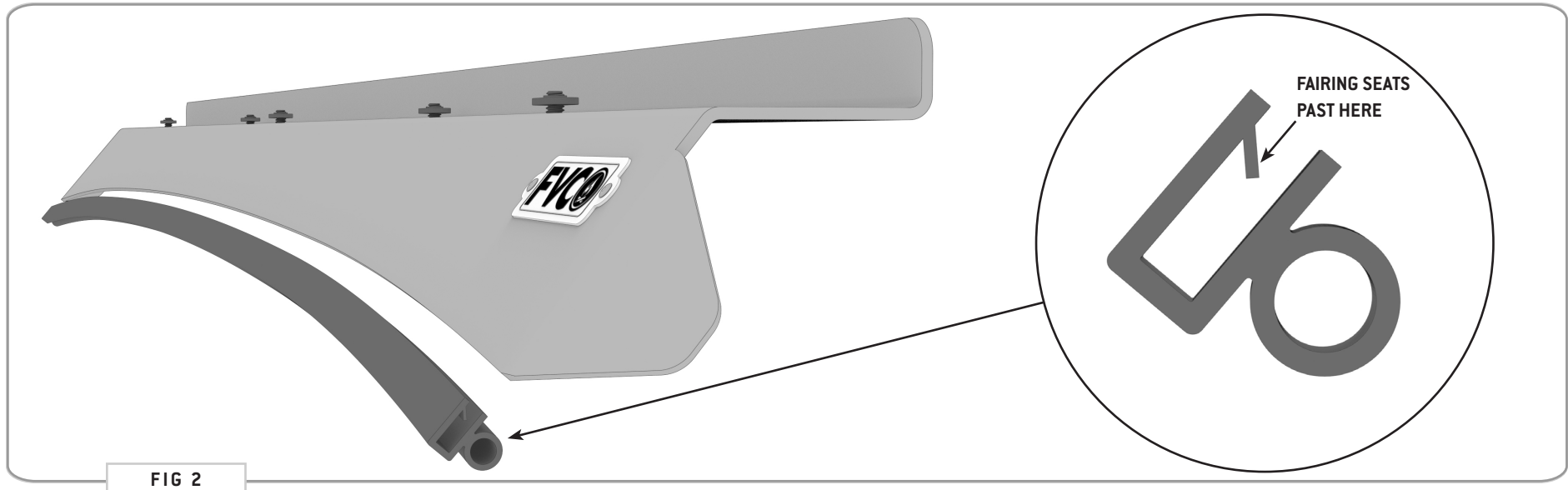
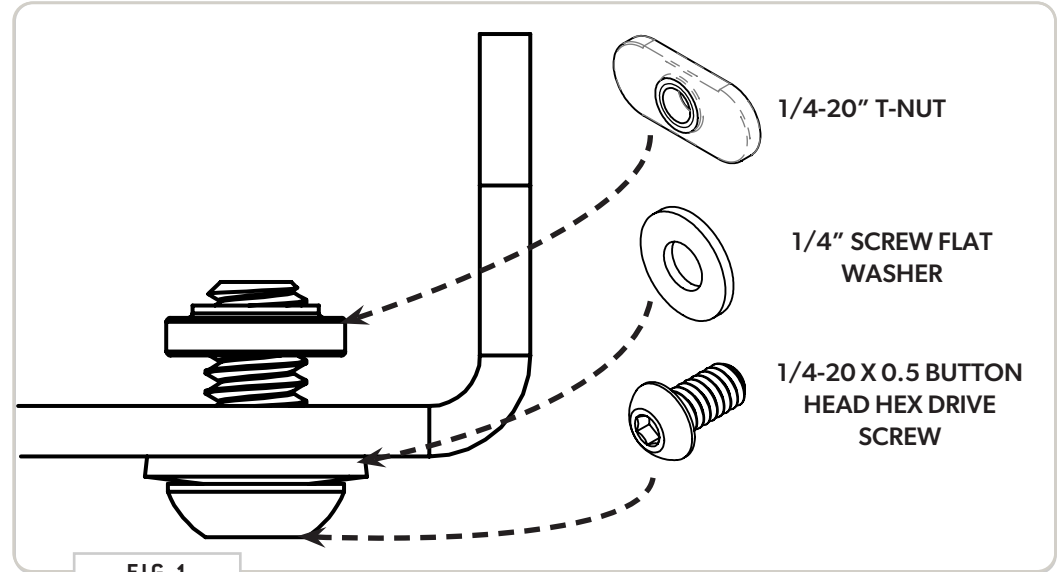

**TOOLS REQUIRED FOR THIS STEP:** + 5/32" ALLEN WRENCH  
+ 3/16" ALLEN WRENCH

## STEP | 02 FAIRING INSTALL

**2.1 Crossbar Install:** Now, slide the crossbar onto the fairing. You'll have to straighten each t-nut as you go to get it to feed into the crossbar correctly (FIG 3). After sliding the fairing and crossbar together, tighten all five (5) of the 1/4-20" Button Head Screws.

**2.2 Fairing Install:** Now you're ready to attach the fairing to the roof rack. Slide it in from the front and into the location shown in FIG 4 and tighten down using (2) 1/4-20" Flange Head Screws.

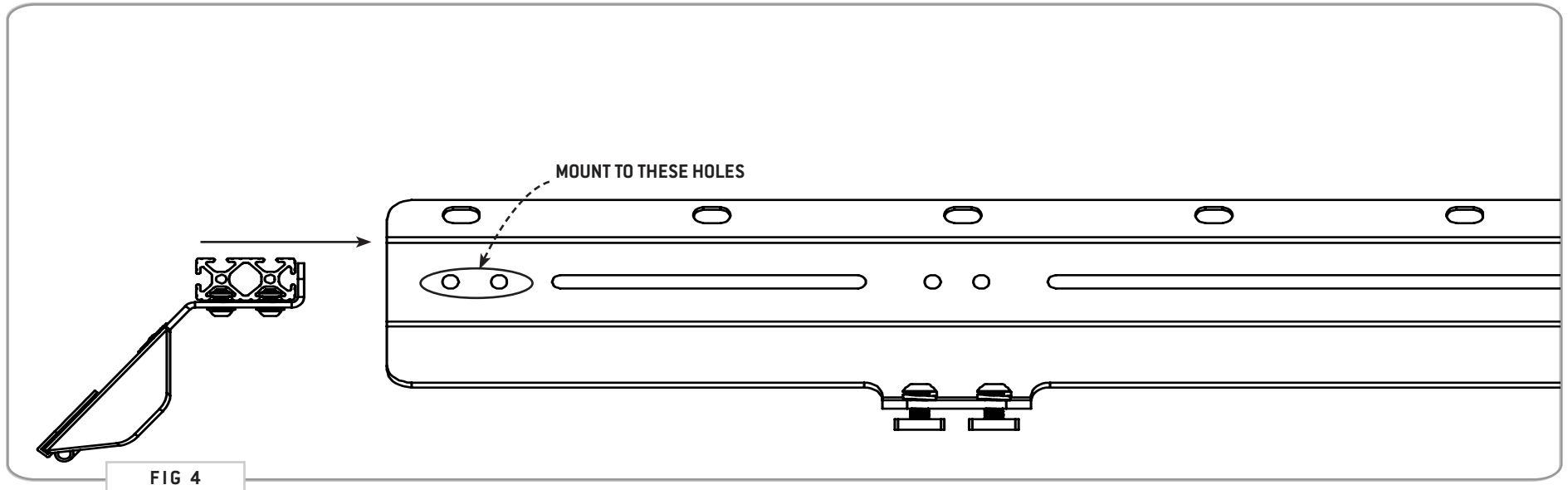
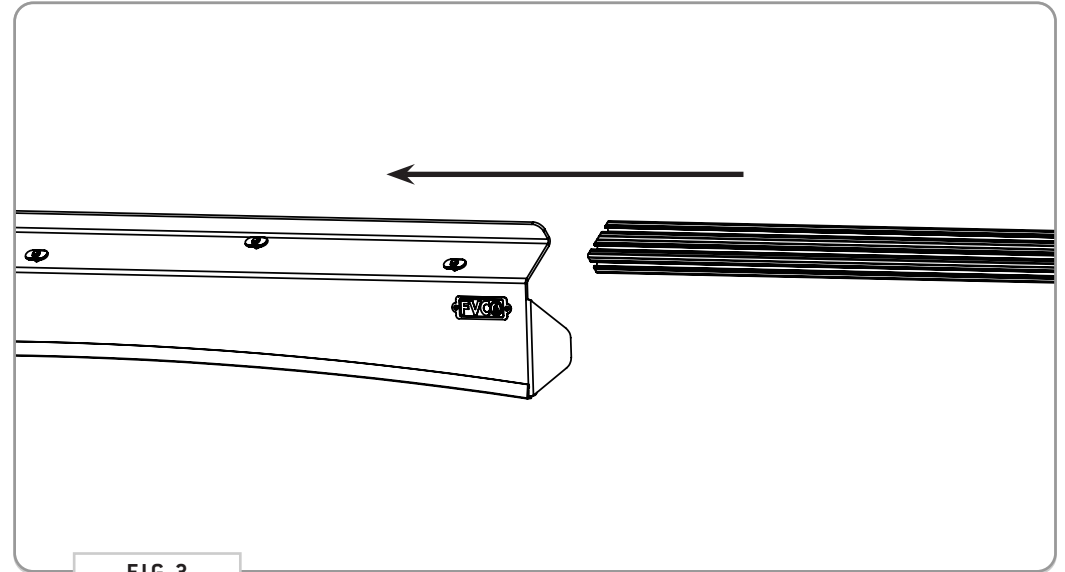

# GET OUT AND EXPLORE!

## + LEAVE US A REVIEW

---

Happy with your new FVC product? We would love to hear (and see) from you! Head to the product page and click "Leave Review." Add a short review and upload a few photos to be showcased on the product page.

## + SHARE YOUR PICS

---

We love seeing how our customers use their FVC products and following along with your adventures. Tag us in your photos with: @flatlinevanco or send them to us via email. We love posting customer pictures in our feed!

## + NEED ANY HELP?

---

If you are having any issues with your product, please reach out, and we will make it right. FVC is a company of van and outdoor enthusiasts that design and use our own products, so we want you to be as stoked on your new parts as we are!



@FLATLINEVANCO