



# INSTALLATION GUIDE

## SPRINTER VAN SAFARI RACK - 170" DROP FRONT SP0108B



### TOOLS REQUIRED (NOT INCLUDED)

- + MEASURING TAPE
- + QWICK CLAMPS
- + 3/8" WRENCH OR SOCKET
- + 7/16" WRENCH OR SOCKET
- + 9/16" WRENCH OR SOCKET
- + 5/32" ALLEN WRENCH

### INSTALL INFO

TIME TO INSTALL THIS PRODUCT: 3-4 HOURS

Additional help is suggested for a few of the install steps.

### BEFORE YOU START

Please inspect the product and packaging upon delivery to ensure there are no issues and that all parts and hardware are accounted for.

Contact us ASAP if anything is missing at:  
[support@flatlinevanco.com](mailto:support@flatlinevanco.com)

# BEFORE YOU START

All Flatline Van Co products must be properly assembled and secured before attaching to your vehicle. Improper attachment could result in an automobile accident, and could cause serious bodily injury or death to you or to others involved. You are responsible for assembling and securing Flatline Van Co products to your vehicle, checking the mounting points and attachments prior to use, and regularly inspecting the products for wear and or damage. We always recommend you use a professional to install any aftermarket accessories to your vehicle. If you have no mechanical experience and are not thoroughly familiar with the installation procedures, you must have the product installed by a professional installer or other qualified persons. The responsibility is yours and must be taken seriously for everyone's safety.



# PACKAGE CONTENTS

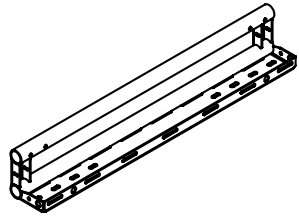

SIDE RAIL

QTY: 8

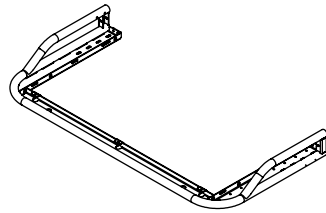

FRONT BASKET

QTY: 1

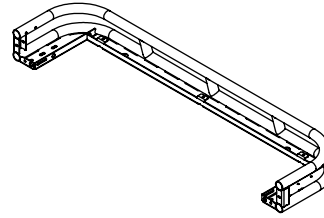

REAR BASKET

QTY: 1

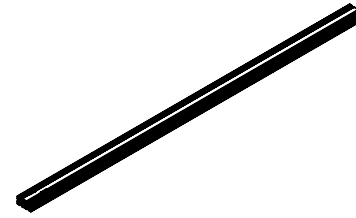

CROSSBAR

QTY: 7

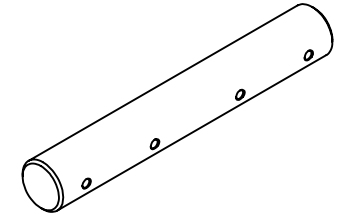

BAYONET

QTY: 10

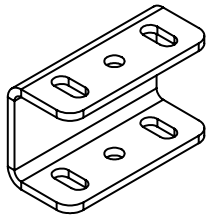

SAFARI RAIL MOUNT

QTY: 10

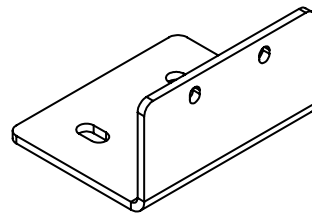

F45 AWNING BRACKET

QTY: 3

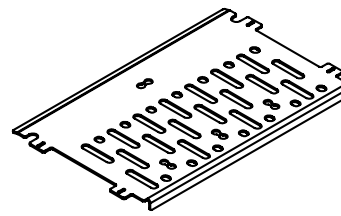

FLOOR SECTION FAN SIDE PANEL

QTY: 4

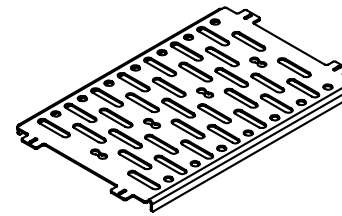

FLOOR SECTION FAN COVER

QTY: 2

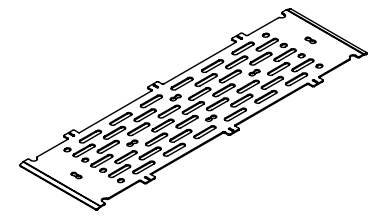

FLOOR SECTION 2

QTY: 2

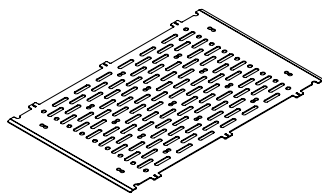

FLOOR SECTION 4

QTY: 1

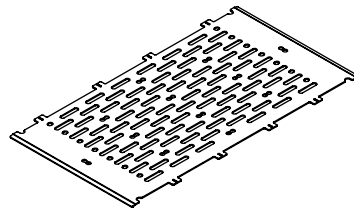

FLOOR SECTION 5

QTY: 1

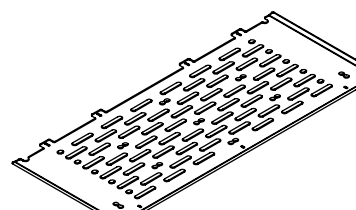

FLOOR SECTION 1

QTY: 1

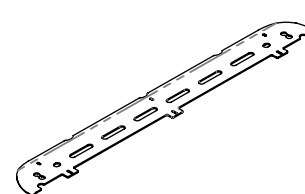

FLOOR SECTION 8

QTY: 1

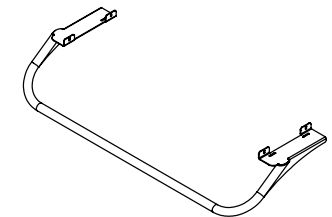

DROP FRONT

QTY: 1

# HARDWARE

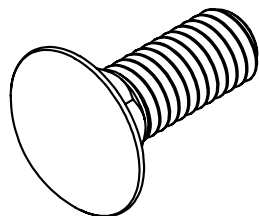

3/8-16 X 1 CARRIAGE BOLT

QTY: 26

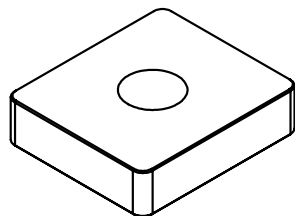

RAIL NUTS

QTY: 10

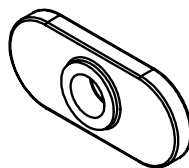

1/4-20 T-NUT

QTY: 57

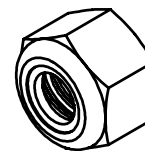

3/8-16 NYLON LOCKNUT

QTY: 26

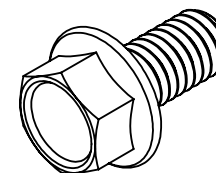

3/8-16 X 0.75 FLANGED HEX  
HEAD SCREW

QTY: 10

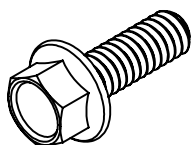

1/4-20 X 0.75 FLANGED HEX  
HEAD SCREW

QTY: 40

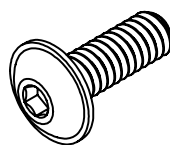

1/4-20 X 0.75 FLANGED BUTTON  
HEAD HEX DRIVE SCREW

QTY: 46

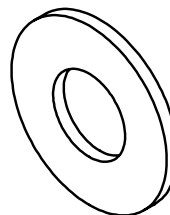

3/8 SCREW FLAT WASHER

QTY: 26

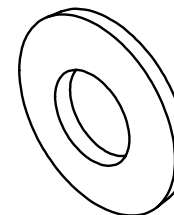

3/8 BELLEVILLE LOCK WASHER

QTY: 10

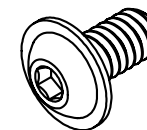

1/4-20 X 0.5 FLANGED BUTTON  
HEAD HEX DRIVE SCREW

QTY: 57



1/4 SCREW FLAT WASHER

QTY: 12

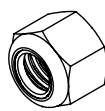

1/4-20 NYLON LOCKNUT

QTY: 18

TOOLS REQUIRED FOR THIS STEP: + MEASURING TAPE

## STEP | 01 LAYOUT AND INSTALL PREP

**1.1 Install Rail Nuts:** Slide (5) Rail Nuts into the Passenger Side factory roof rail (FIG 1), and (5) into the Driver Side rail. If you purchased a Side Ladder to go with your Safari Rack (FIG 2), add two more to the Driver Side Rail in the location shown in FIG 2+3.

**1.2 Layout Rail Nuts:** Space out the Rail Nuts close to their final positions as roughly laid out in FIG 3.

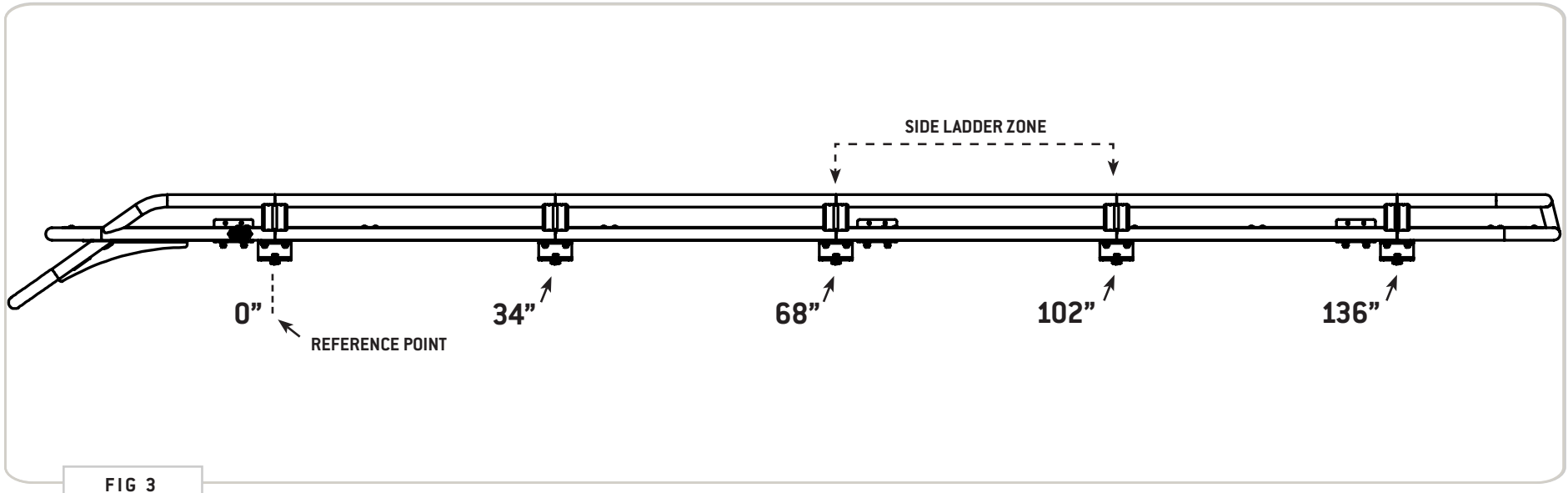
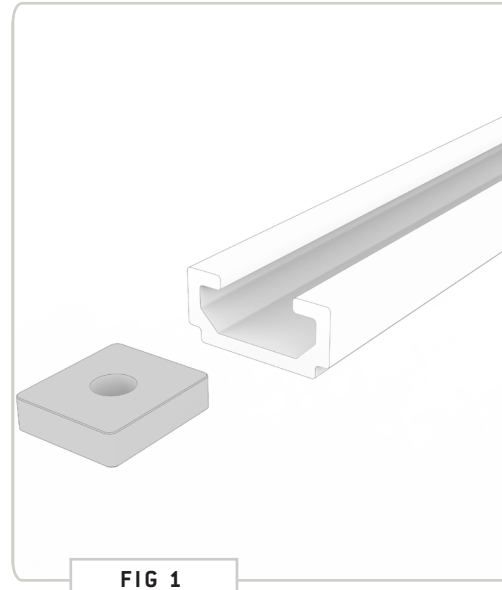

**TOOLS REQUIRED FOR THIS STEP:** + 5/32" ALLEN WRENCH  
+ 9/16" WRENCH OR SOCKET

## STEP | 02 SIDE RAIL ASSEMBLY

**2.1 Assemble Side Rails:** Insert a **Bayonet** into the end of a **Side Rail** (FIG 5+6) and use (2) 1/4-20 x 0.75 **Flanged Button Head Screws** (not the shorter ones) to loosely secure the **Bayonet** in place.

**2.2 Assemble Side Rails:** Attach another **Side Rail** piece to the protruding end of the **Bayonet** and repeat the process on the other side of the **Side Rail**. See FIG 4 for layout of components.

**2.3 Attach Mounting Brackets:** Attach **Mounting Brackets** to the **Side Rails** using (2ea) 3/8-16" x 0.75 **Carriage Bolts**, 3/8" **Flat Washers** and **Nylon Locknuts** (FIG 5+7).

**NOTE** - The carriage bolts that attach the rail mounts can be mounted facing upward or downward for a clean look.

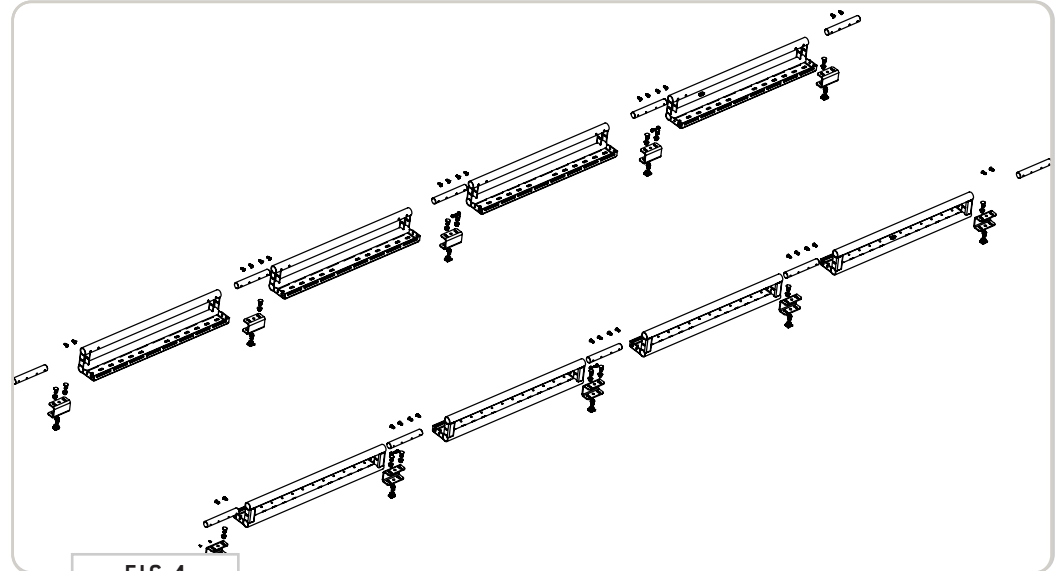

FIG 4

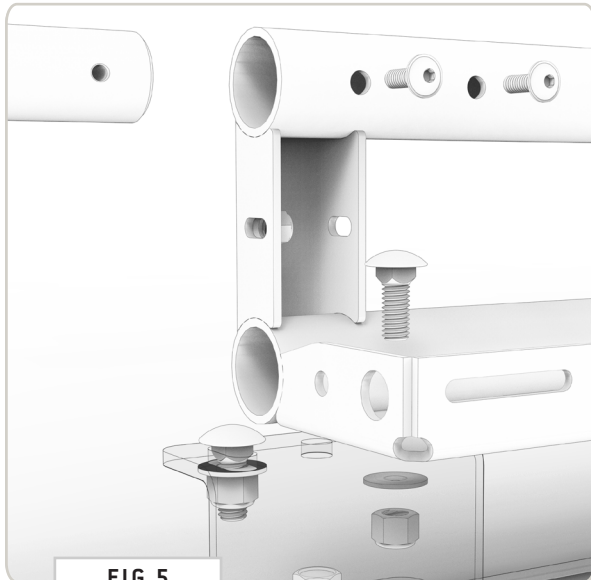

FIG 5



FIG 6



FIG 7

## STEP | 02 SIDE RAIL INSTALL

**2.4 Fasten Side Rails Together:** Secure the connection with a **1/4-20 Flanged Hex Bolt, Washer and Nylon Locknut**. Insert the bolt through the smaller hole inside the larger wire pass-through hole (**FIG 7**).

**NOTE** - Use clamps to ensure the seams are tight while you tighten the bolts (**FIG 6**).

**TOOLS REQUIRED FOR THIS STEP:**

- + QUICK CLAMPS
- + 3/8" WRENCH OR SOCKET
- + 7/16" WRENCH OR SOCKET



FIG 6



FIG 7

TOOLS REQUIRED FOR THIS STEP: + 9/16" WRENCH OR SOCKET

## STEP | 03 SIDE RAIL INSTALL

**3.1 Mount Side Rails to Van Rails:** With assistance, lift the **Side Rail Assembly** onto the roof (**FIG 8**). Align the Mounting Feet with the roof **Rail Nuts** and insert a **3/8-16" Flanged Hex Head Bolt and Belleville Lock Washer** into the available mounting hole as shown in **FIG 9**. Once loosely assembled, slide rails all the way to very front of your roof rail.

**NOTE** - Leave these bolts loose; we'll come back and tighten them at a later step.



FIG 8

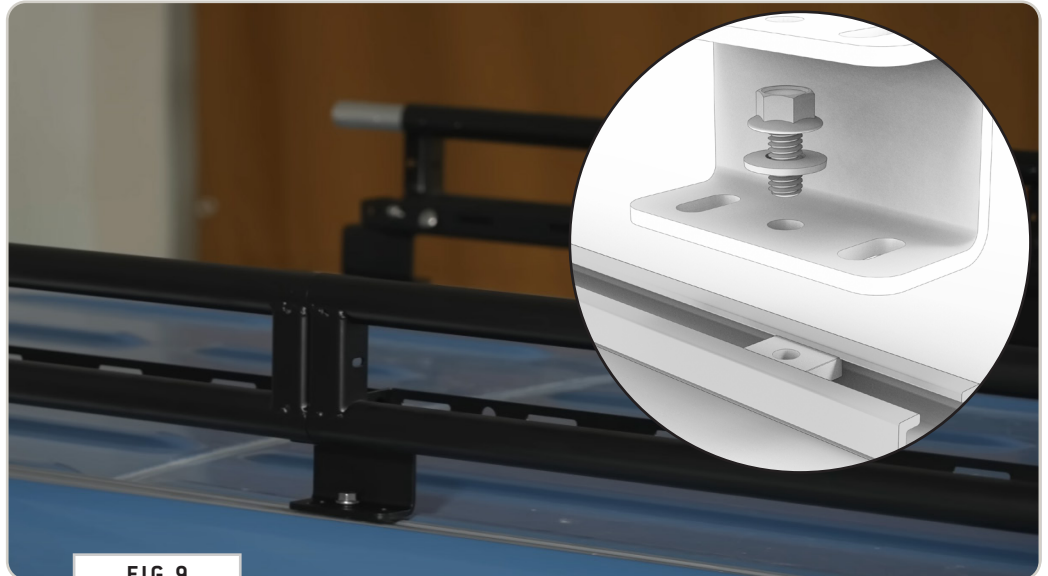

FIG 9



## STEP | 04 ATTACH BASKETS TO RAILS

**4.1 Attach Front and Rear Baskets:** With help, carefully attach the **Front Basket** to the protruding **Bayonets** and secure the connections using (2) **1/4-20 x 0.75 Flanged Button Head Screws** (not the shorter ones) for the **Bayonets** and a **1/4-20 Flanged Hex Bolt, Washer and Nylon Locknut** for the **Side Rail** connection.

**NOTE** - Use clamps to ensure the seams are tight while you tighten the bolts (FIG 11).

**NOTE** - Remember to leave the rail mount feet loosened. We'll tighten those down in a later step.

**TOOLS REQUIRED FOR THIS STEP:** + 5/32" ALLEN WRENCH  
+ QWICK CLAMPS  
+ 3/8" WRENCH OR SOCKET  
+ 7/16" WRENCH OR SOCKET

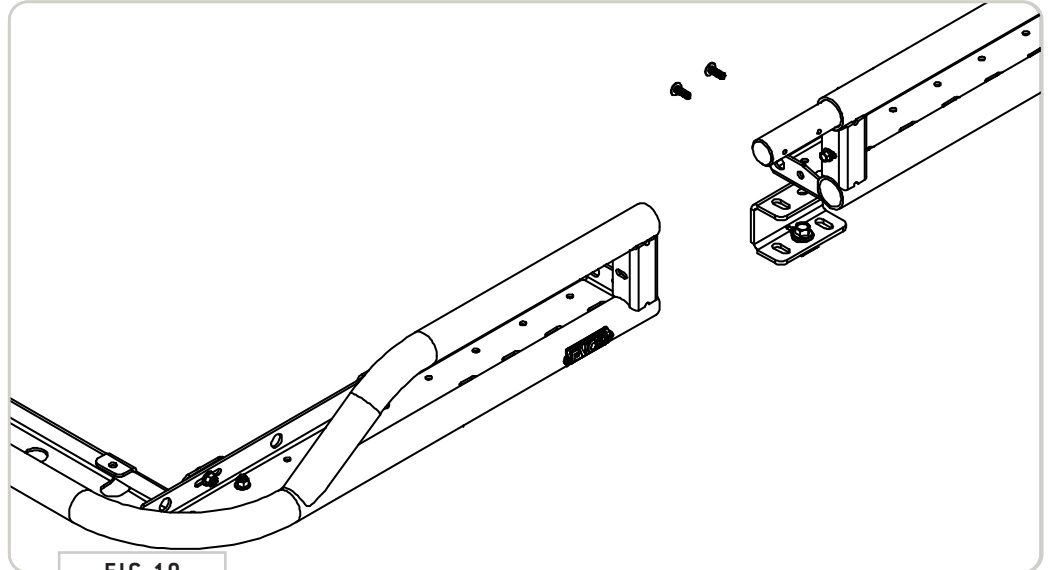

FIG 10



FIG 11

## STEP | 05 ATTACH DROP FRONT

**5.1 Attach Drop Front:** The Drop Front mounts to the underside tray of the Front Basket Weldment. You will need to maneuver it around your antenna to get it in place, so having a second person helps immensely for this step. FIG 13 and 14 details how the Drop Front fastens to the Front Basket. Use a **1/4-20 Flanged Hex Bolt, Washer and Nylon Locknut** in the locations shown.

**NOTE** - We recommend installing your lighting setup to the Drop Front weldment prior to installing it on the rack. This makes adjustments and placement a bit easier.

**TOOLS REQUIRED FOR THIS STEP:**

- + 3/8" WRENCH OR SOCKET
- + 7/16" WRENCH OR SOCKET

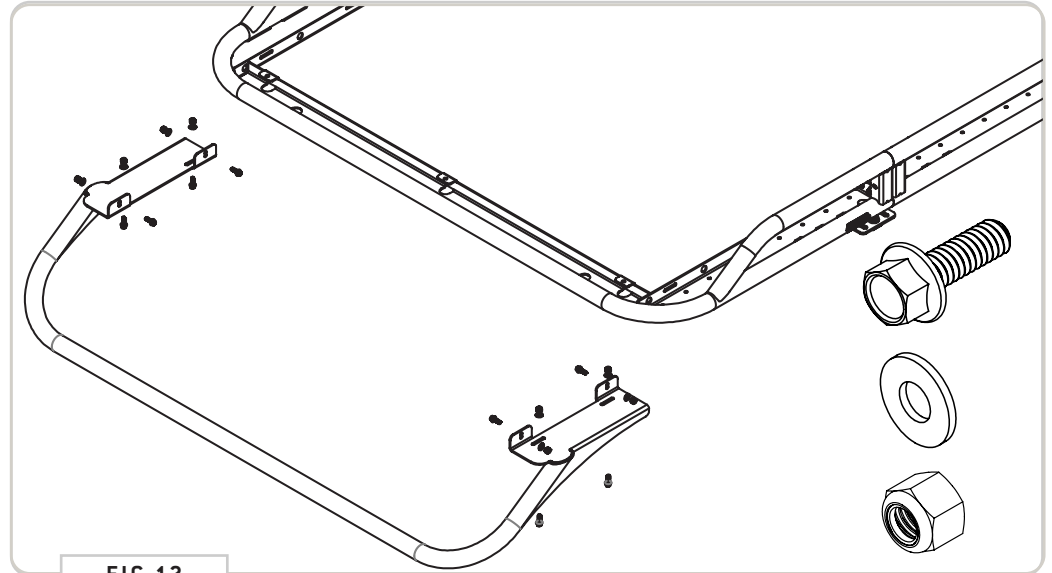

FIG 12

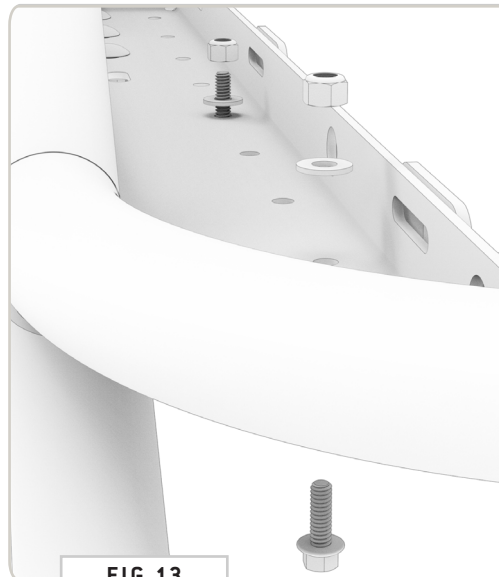

FIG 13



FIG 14

**TOOLS REQUIRED FOR THIS STEP:** + MEASURING TAPE  
+ 9/16" WRENCH OR SOCKET

## STEP | 06 INSTALL AWNING BRACKETS

**6.1 F45 Awning Brackets (optional):** If you purchased a Fiamma F45 Awning with your rack, install the (3) Awning Brackets at this time using (2ea) 3/8-16" Carriage Bolts, Flat Washers and Nylon Locknuts. See FIG 16 for locations.



FIG 15

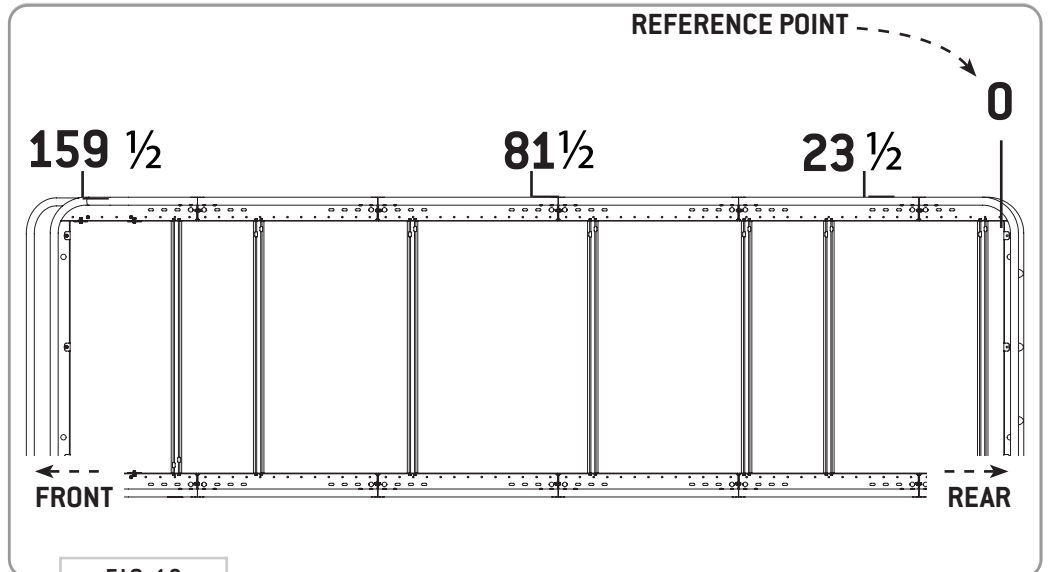

FIG 16

**TOOLS REQUIRED FOR THIS STEP:** + MEASURING TAPE  
 + 7/16" WRENCH OR SOCKET

## STEP | 07 INSTALL CROSSBARS

**7.1 Attach Crossbars:** Using (4ea) 1/4-20 Flanged Hex Bolts with Loctite (FIG 14), attach Crossbars to the rack in the locations shown in FIG 18. Be sure to measure both sides to ensure that the crossbars are square.

**NOTE** - Remember to leave the rail mount feet loosened. We'll tighten those down in a later step.

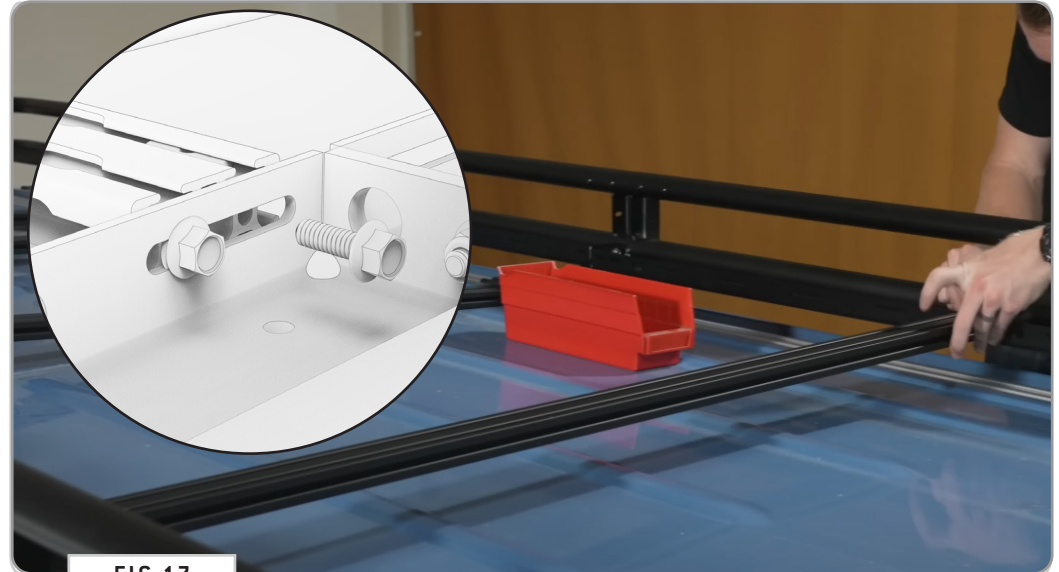

FIG 17

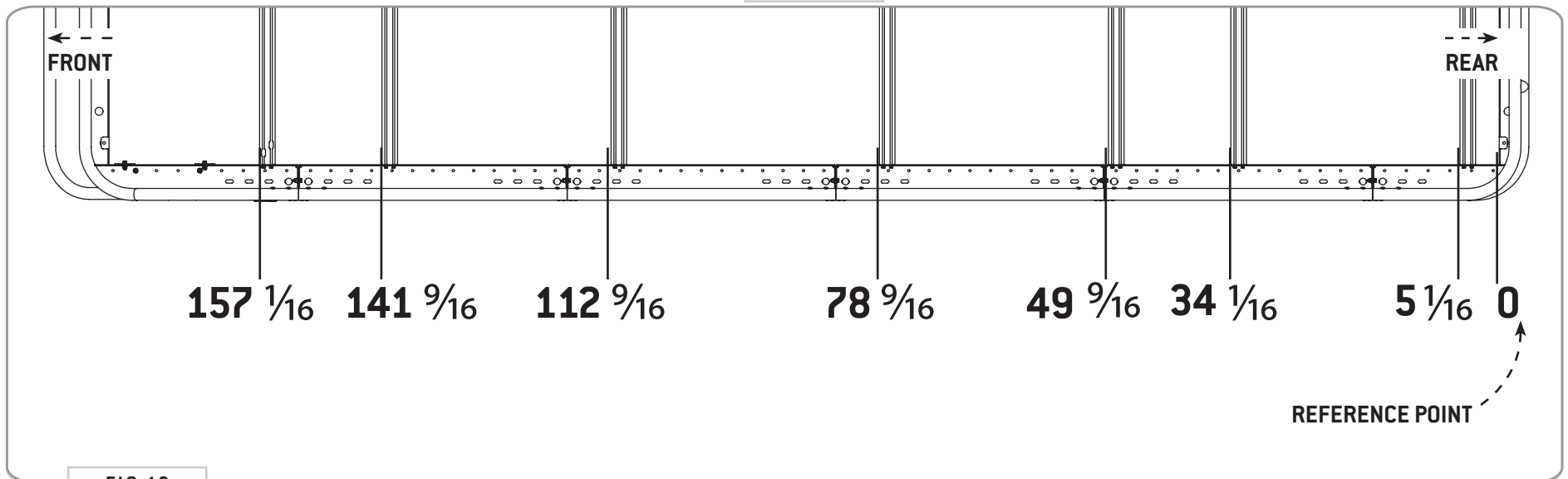

FIG 18

## STEP | 08 PREP FOR PANELS

**8.1 Attach Clip Nuts to Baskets:** Install the **Clip Nuts** to the **Front and Rear Basket** locations as shown in **FIG 19**.

**NOTE** - The flat side of the **Clip Nut** should be facing upwards (**FIG 20**)

TOOLS REQUIRED FOR THIS STEP:

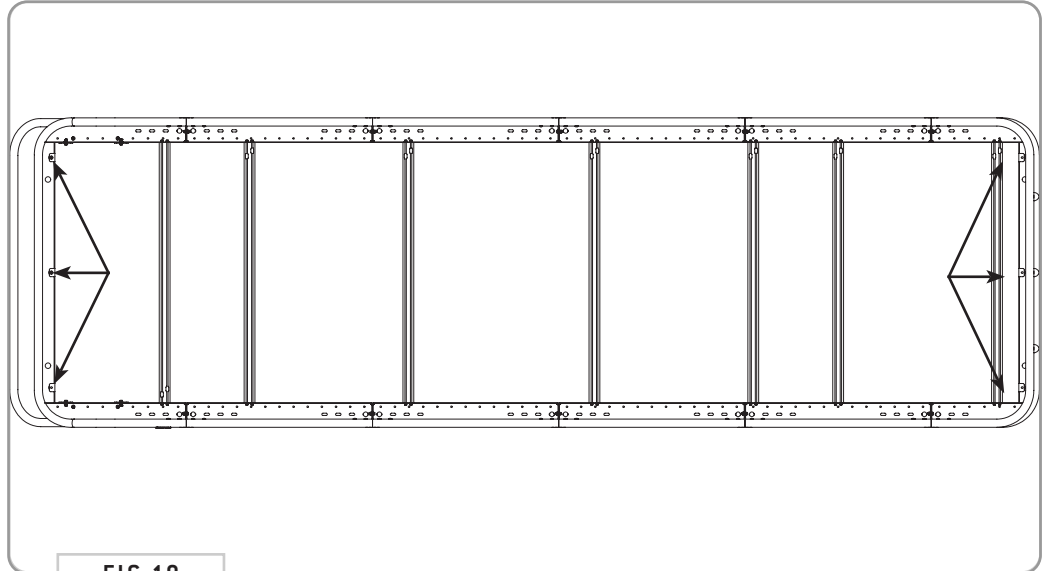

FIG 19

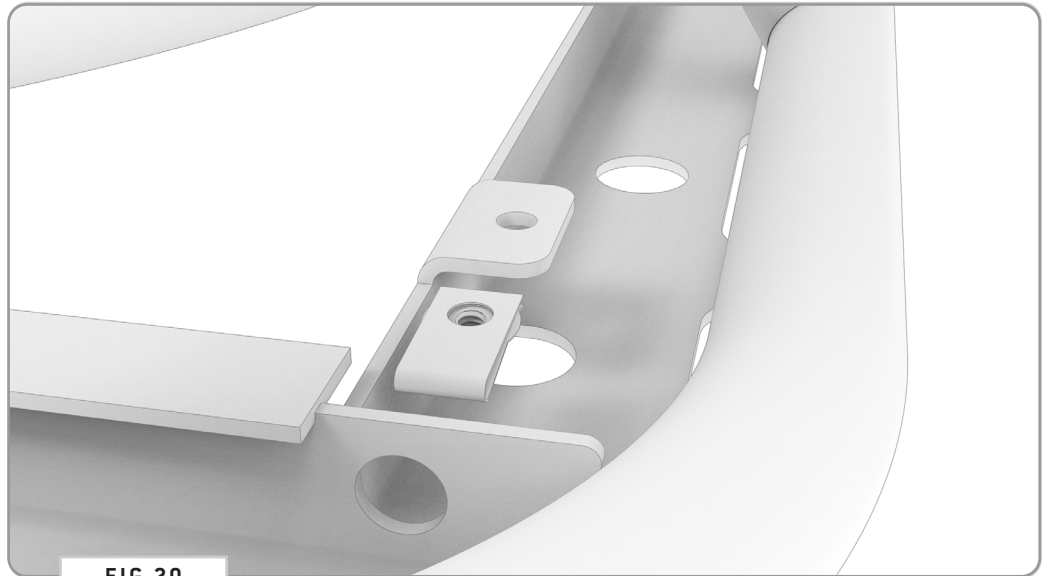

FIG 20

TOOLS REQUIRED FOR THIS STEP:

### STEP | 08 PREP FOR PANELS

**8.2 Layout T-Nuts:** Consider the layout plan of your roof accessories and install T-Nuts into the available slots of the Crossbars as shown in **FIG 21**. See **FIG 22** for amounts of T-Nuts needed per slot if using exclusively decking panels.

**NOTE** - The flat side of the **T-Nuts** should be facing upwards when installing to **Crossbar**.



FIG 21

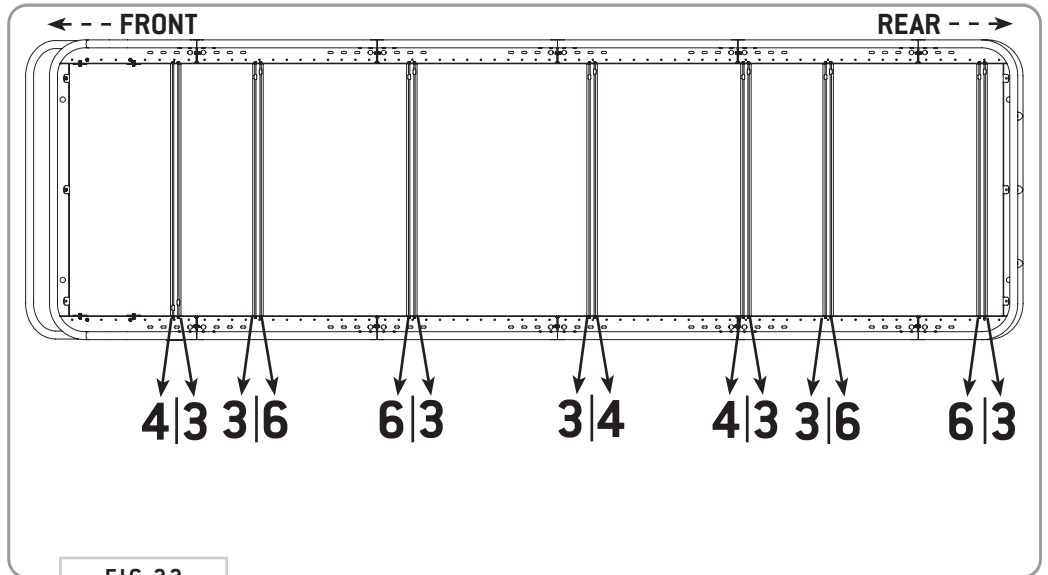

FIG 22

## STEP | 09 INSTALL FLOOR PANELS

**9.1 Install Floor Panels:** Begin to layout your **Decking Panels** along the locations shown in **FIG 23**. Adjust the **T-Nuts** as necessary to line up with the available pill slots of the **Decking Panels** (**FIG 24**).

### TOOLS REQUIRED FOR THIS STEP:

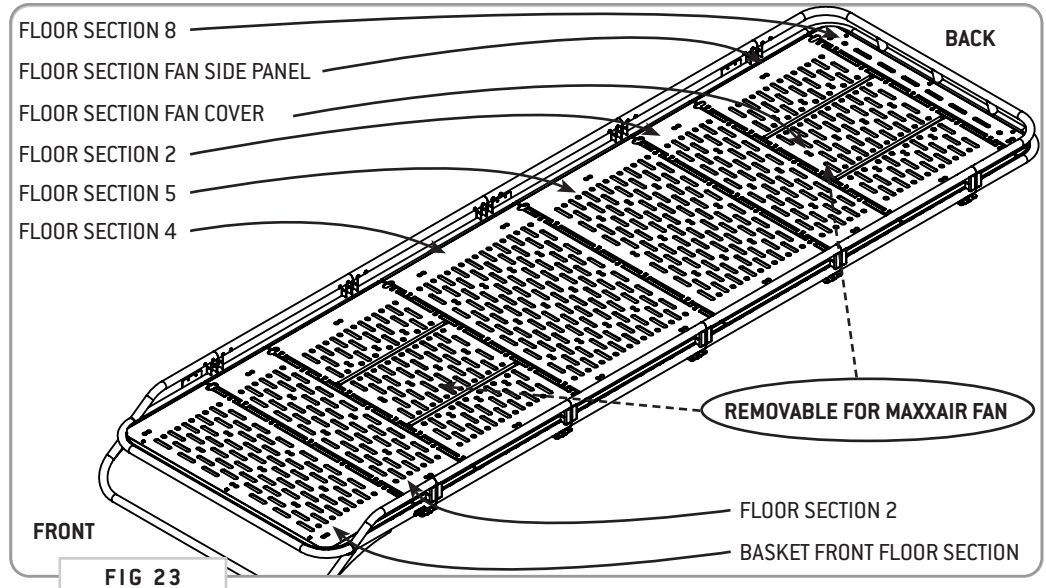

FIG 23

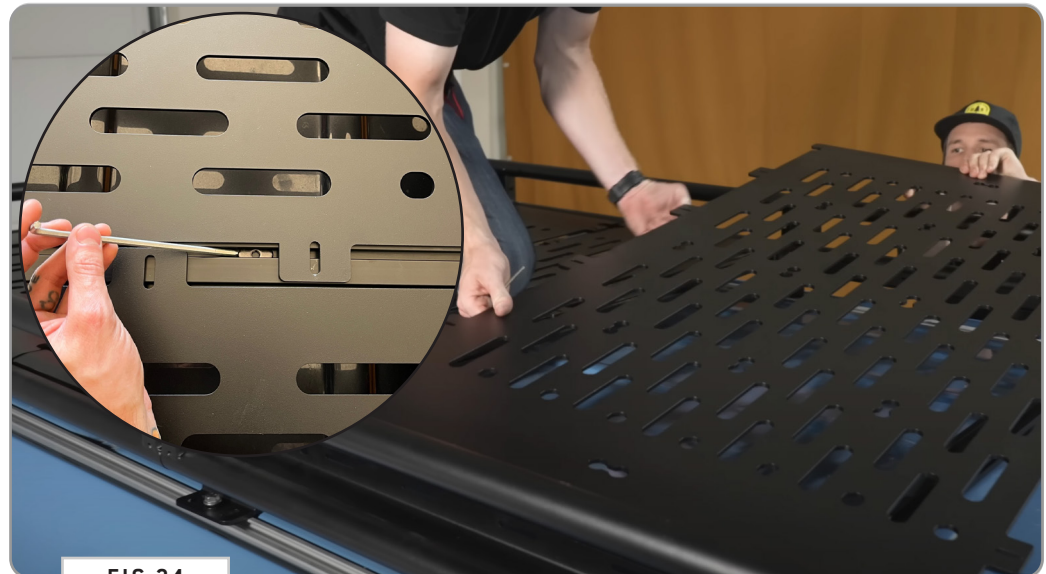

FIG 24

TOOLS REQUIRED FOR THIS STEP: + 5/32" ALLEN WRENCH

## STEP | 09 INSTALL FLOOR PANELS

**9.2 Install Floor Panels:** Note that the front and rear-most panels have pill slots for attaching to the **Clip Nuts** installed earlier (FIG 25). Use the **1/4-20 x 0.5" Flanged Button Head Screws** for the **Decking Panels** that attach to **Crossbars**, and the longer **0.75" Screws** for the ones that attach to the **Clip Nuts** (FIG 26).



FIG 25

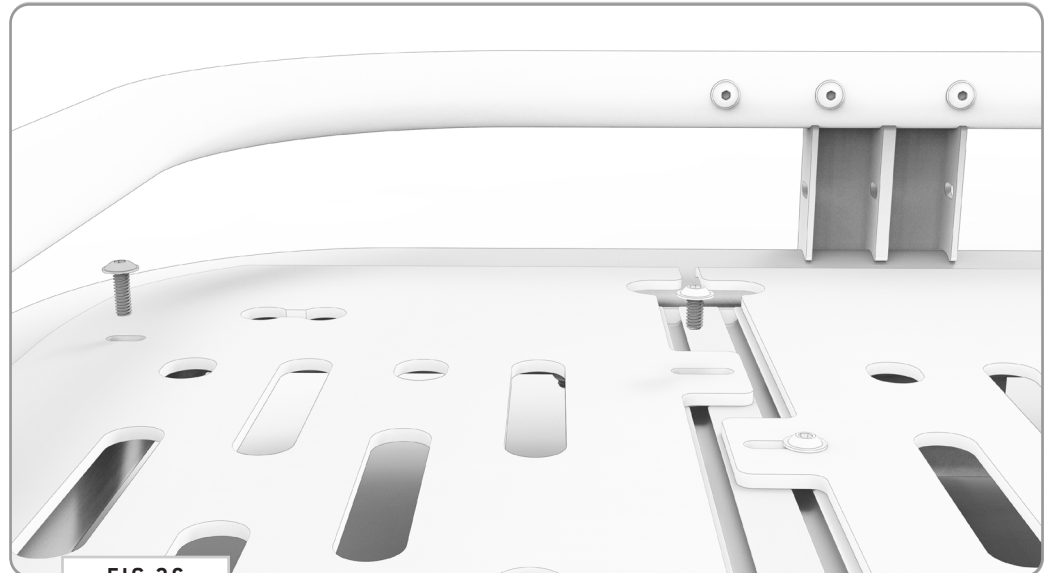

FIG 26



## STEP | 10 FINAL ADJUSTMENTS

**10.1 Tighten Fasteners:** Once you've got all of the floor sections bolted down, do a once-over of all fasteners on the rack to ensure they are tight and secure. Install is now complete, and you're ready for adventure!

- TOOLS REQUIRED FOR THIS STEP:**
- + 3/8" WRENCH OR SOCKET
  - + 7/16" WRENCH OR SOCKET
  - + 9/16" WRENCH OR SOCKET
  - + 5/32" ALLEN WRENCH

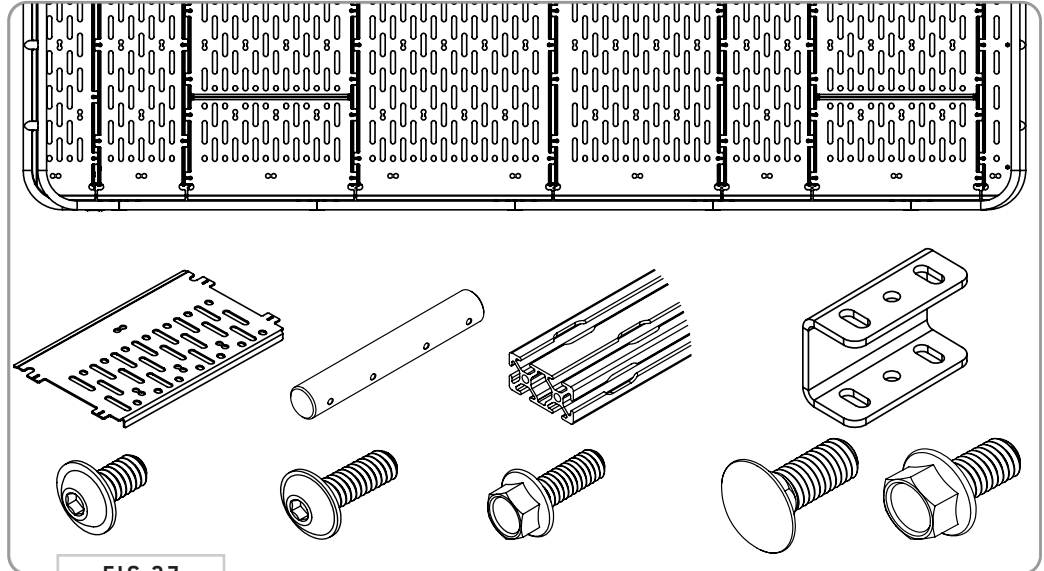

# GET OUT AND EXPLORE!

## + LEAVE US A REVIEW

---

Happy with your new FVC product? We would love to hear (and see) from you! Head to the product page and click "Leave Review." Add a short review and upload a few photos to be showcased on the product page.

## + SHARE YOUR PICS

---

We love seeing how our customers use their FVC products and following along with your adventures. Tag us in your photos with: @flatlinevanco or send them to us via email. We love posting customer pictures in our feed!

## + NEED ANY HELP?

---

If you are having any issues with your product, please reach out, and we will make it right. FVC is a company of van and outdoor enthusiasts that design and use our own products, so we want you to be as stoked on your new parts as we are!



@FLATLINEVANCO