

# FVCO<sup>®</sup>

**Installation Guide**



## **Safari Rack 144 SP0104B**

All Flatline Van Co products must be properly assembled and secured before attaching to your vehicle. Improper attachment could result in an automobile accident, and could cause serious bodily injury or death to you or to others involved. You are responsible for assembling and securing Flatline Van Co products to your vehicle, checking the mounting points and attachments prior to use, and regularly inspecting the products for wear and or damage. We always recommend you use a professional to install any aftermarket accessories to your vehicle. If you have no mechanical experience and are not thoroughly familiar with the installation procedures, you must have the product installed by a professional installer or other qualified persons. The responsibility is yours and must be taken seriously for everyone's safety.



thanks.

# THANK YOU!

ARE YOU EXCITED ABOUT YOUR NEW SAFARI RACK 144? HERE ARE A FEW THINGS TO DO BEFORE BEGINNING THE INSTALLATION PROCESS--

- PLEASE INSPECT THE PRODUCT TO ENSURE THERE WAS NO DAMAGE INCURRED DURING SHIPPING.
- IF THERE IS DAMAGE TO REPORT, PLEASE CONTACT OUR CUSTOMER SERVICE DEPARTMENT AS SOON AS POSSIBLE.
- NEXT, USING THE "PACKAGE CONTENTS" PAGE, CHECK INVENTORY AND FAMILIARIZE YOURSELF WITH THE PARTS AND HARDWARE.
- GATHER ALL TOOLS REQUIRED FOR INSTALL.
  - 3/8 BOX WRENCH OR SOCKET
  - 7/16 BOX WRENCH OR SOCKET
  - 9/16 BOX WRENCH OR SOCKET
  - 5/32 HEX KEY ALLEN WRENCH

ESTIMATED INSTALL TIME- 4 HRS

ADDITIONAL HELP IS SUGGESTED FOR A FEW OF THE INSTALL STEPS.

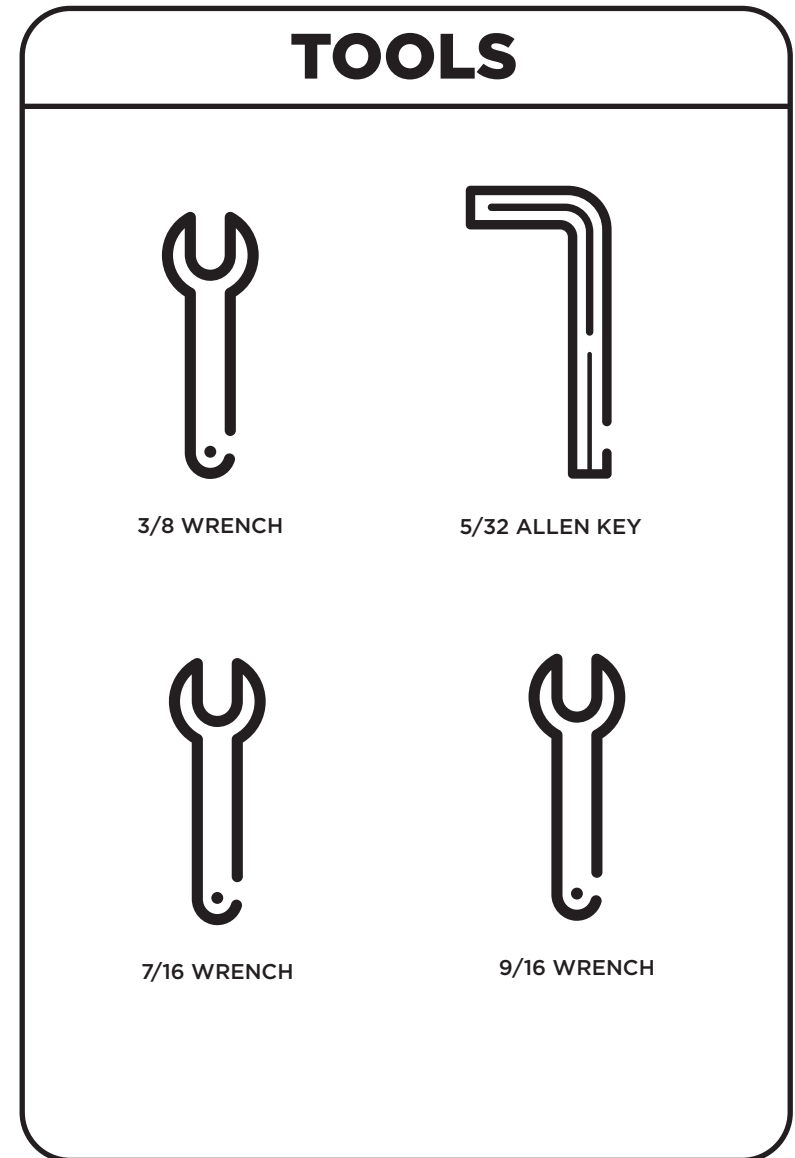

# PACKAGE CONTENTS

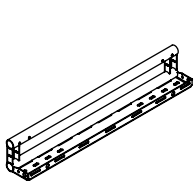

SIDE RAIL WELDMENT

QTY - 6

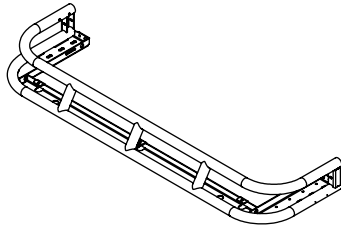

FRONT BASKET WELDMENT

QTY - 1

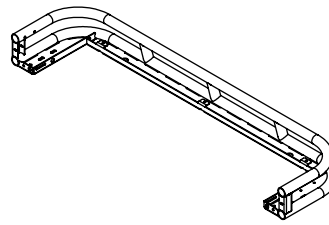

144 REAR BASKET WELDMENT

QTY - 1

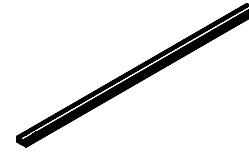

47.5" CROSSBAR

QTY - 5

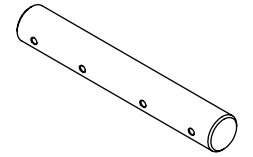

1.1875 BAYONET

QTY - 8

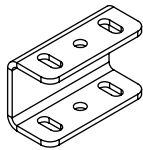

SPRINTER SAFARI RAIL MOUNT

QTY - 8

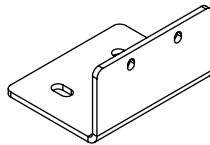

F45 MOUNTING BRACKET

QTY - 3

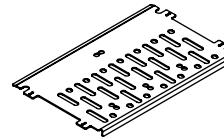

FLOOR SECTION FAN SIDE PANEL

QTY - 4

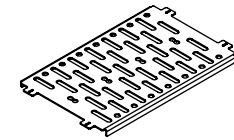

FLOOR SECTION FAN COVER

QTY - 2

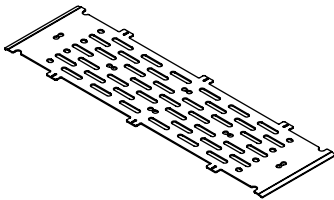

FLOOR SECTION 2

QTY - 1

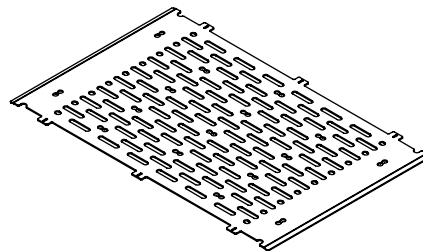

FLOOR SECTION 4

QTY - 1

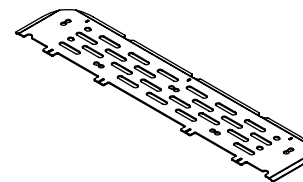

BASKET FRONT FLOOR SECTION

QTY - 1

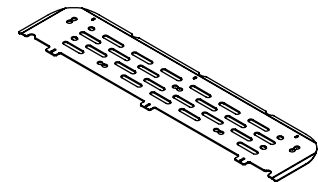

FLOOR SECTION 6

QTY - 1

# HARDWARE

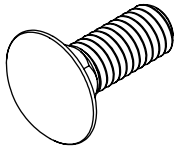

0.375-16 X 1 SQUARE NECK  
CARRIAGE BOLT

QTY - 22

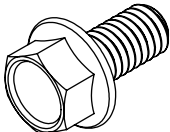

3/8-16 X 0.75 FLANGED HEX  
HEAD SCREW

QTY - 8

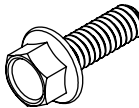

1/4-20 X 0.75 FLANGED HEX  
HEAD SCREW

QTY - 28

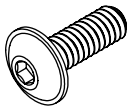

1/4-20 X 0.75 FLANGED BUTTON HEAD  
HEX DRIVE SCREW

QTY - 38

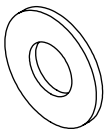

3/8 SCREW FLAT WASHER

QTY - 22

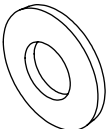

3/8 SCREW BELLEVILLE SPRING  
LOCK WASHER

QTY - 8



1/4-20 X 0.5 FLANGED BUTTON  
HEAD HEX DRIVE SCREW

QTY - 43



1/4 SCREW FLAT WASHER

QTY - 8

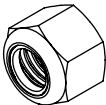

3/8-16 NYLON INSERT LOCKNUT

QTY - 22

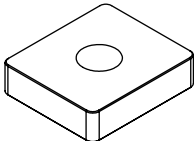

SPRINTER RAIL NUT

QTY - 8

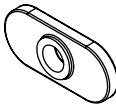

1/4-20 ECONOMY T-NUT

QTY - 43



1/4-20 NYLON INSERT LOCKNUT

QTY - 14

# LET'S GET STARTED!

1. SLIDE HALF OF THE RAIL NUTS INTO THE PASSENGER SIDE FACTORY ROOF RAIL, AND HALF OF THEM INTO THE DRIVER SIDE RAIL.  
**NOTE-** IF YOU'RE INSTALLING A SIDE LADDER, GRAB THE TWO RAIL NUTS FROM YOUR LADDER HARDWARE PACK, AND PUT THOSE TWO IN ON THE DRIVER SIDE. THESE CAN BE ADDED LATER, IT JUST SAVES TIME TO DO IT NOW.

2. NEXT, BEGIN ASSEMBLING YOUR SIDE RAILS. GRAB YOUR 6 **SIDE RAIL WELDMENTS**, 8 **BAYONETS**, AND 8 **RAIL MOUNTS**. BEGIN ASSEMBLING THEM AS SHOWN IN **FIGURE 1**. WE FIND THAT A GOOD SIZED TABLE OR WORKBENCH MAKES THIS A BIT EASIER. TO ASSIST ALIGNMENT, IT'S SUGGESTED TO USE SOME QUICK CLAMPS AS SHOWN IN **DETAIL D** (SEE NEXT PAGE FOR DETAIL). TIGHTEN THE **SIDE RAIL WELDMENTS** AND **BAYONETS**, BUT LEAVE THE **RAIL MOUNTS** SLIGHTLY LOOSE TO ALLOW ADJUSTMENT.

**NOTE-** THE CARRIAGE BOLTS THAT ATTACH THE RAIL MOUNTS CAN BE MOUNTED FACING UPWARD OR DOWNWARD FOR A CLEAN LOOK.

FIGURE 1

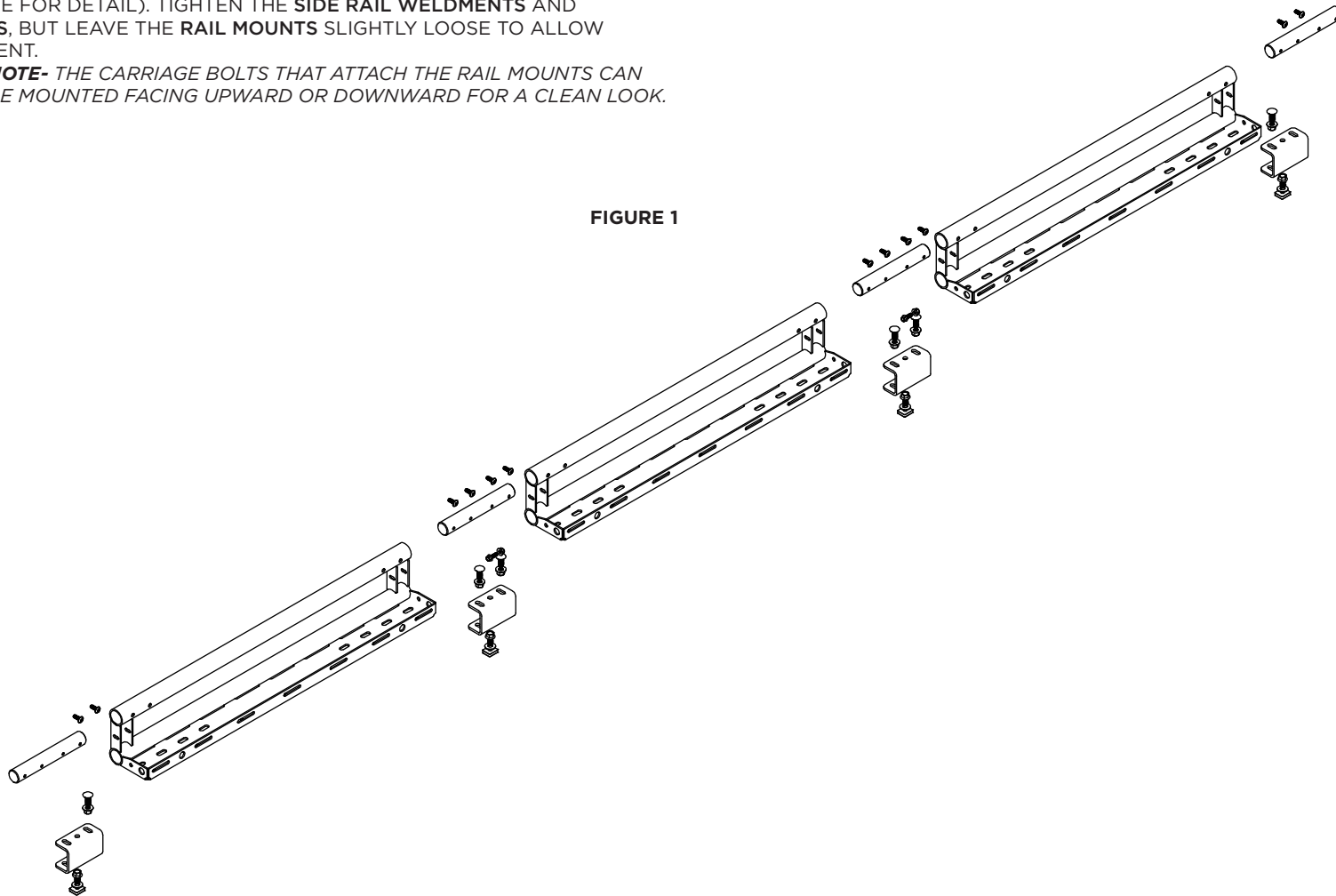

DETAIL A

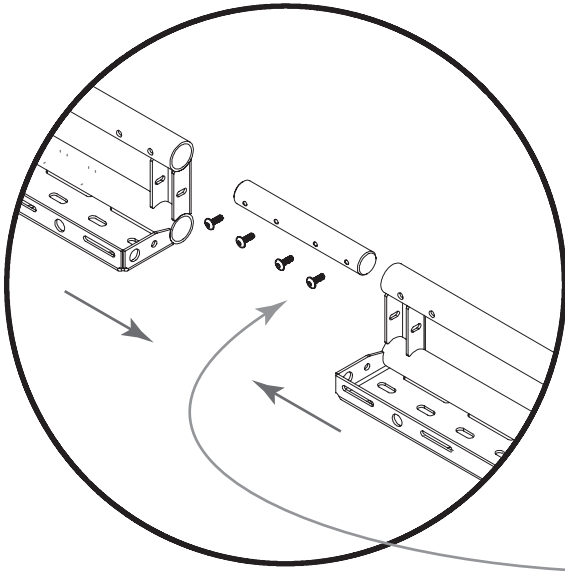

DETAIL B

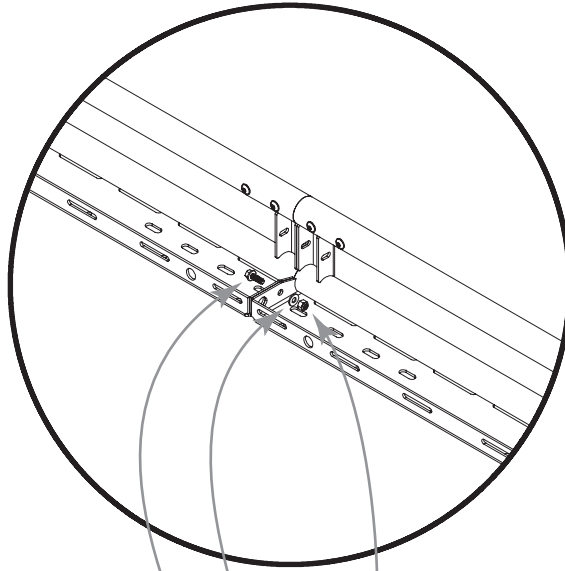

DETAIL C

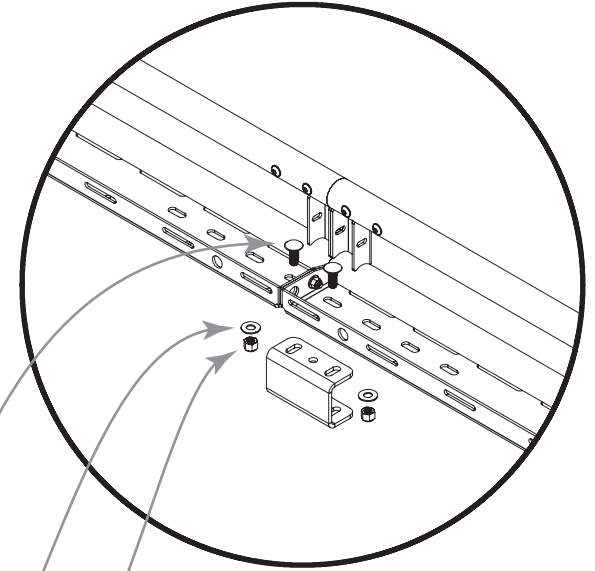

1/4-20 X 0.75 FLANGED BUTTON HEAD  
HEX DRIVE SCREW



1/4-20 X 0.75 FLANGED HEX  
HEAD SCREW

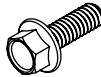

1/4 SCREW FLAT WASHER



1/4-20 NYLON INSERT LOCKNUT



0.375-16 X 1 SQUARE NECK  
CARRIAGE BOLT

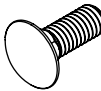

3/8 SCREW FLAT WASHER



3/8-16 NYLON INSERT LOCKNUT



DETAIL D



3. AT THIS POINT, YOU SHOULD HAVE 2 COMPLETE SIDE RAIL ASSEMBLIES AS SHOWN BELOW IN **FIGURE 2**. WITH THE HELP OF A SECOND PERSON, TAKE THE SIDE RAIL ASSEMBLIES UP TO THE TOP OF THE VAN. LINE UP THE FRONT RAIL MOUNT WITH THE VERY FRONT OF YOUR ROOF RAIL.

**NOTE-** LAY A BLANKET OR CARDBOARD DOWN ON THE ROOF OF THE VAN BEFORE BRINGING THE SIDE RAILS UP IF YOU ARE WORRIED ABOUT SCRATCHING THE PAINT.

4. NOW LEAN THE RAIL ASSEMBLY UP AND ONTO THE ROOF RAIL AND THREAD IN THE BOLTS TO THE RAIL NUTS. LEAVE THESE BOLTS LOOSE; WE'LL COME BACK AND TIGHTEN THEM AT A LATER STEP.

**FIGURE 2**

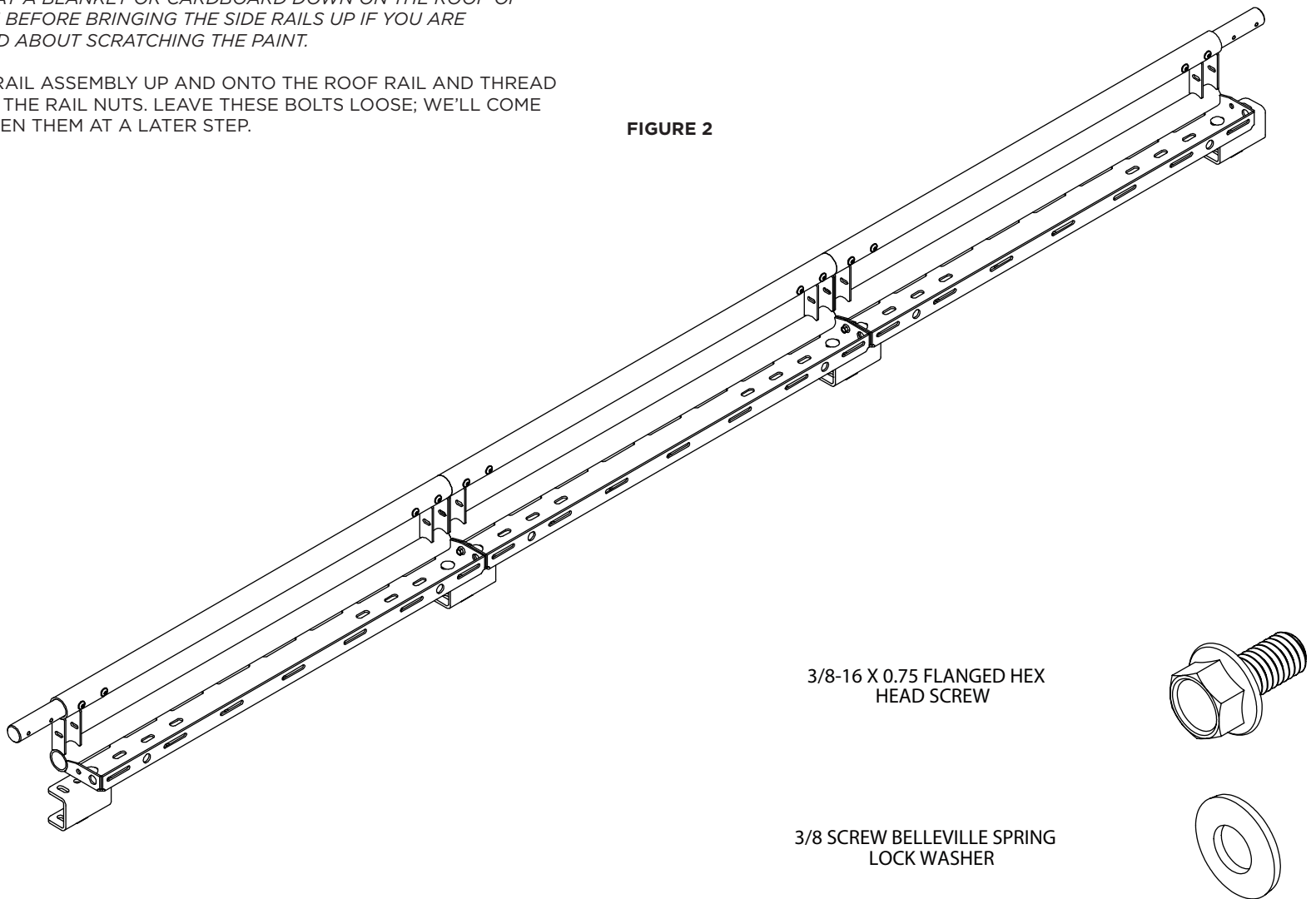



5. WE RECOMMEND HAVING A SECOND SET OF HANDS TO HELP WITH THIS STEP AS WELL. START WITH THE REAR BASKET (SHORTER, DOES NOT HAVE FVC BADGE ON SIDE) AND SLIDE IT ONTO THE EXPOSED BAYONETS ON THE REAR OF THE RACK. ATTACH USING THE SAME HARDWARE USED TO ASSEMBLE THE SIDE RAILS, AND USE THE SAME CLAMPING METHOD AS BEFORE TO ENSURE GOOD ALIGNMENT. REPEAT THE SAME STEPS FOR THE FRONT BASKET.

**NOTE-** REMEMBER TO LEAVE THE RAIL MOUNT FEET LOOSENED. WE'LL TIGHTEN THOSE DOWN IN A LATER STEP.

FIGURE 3

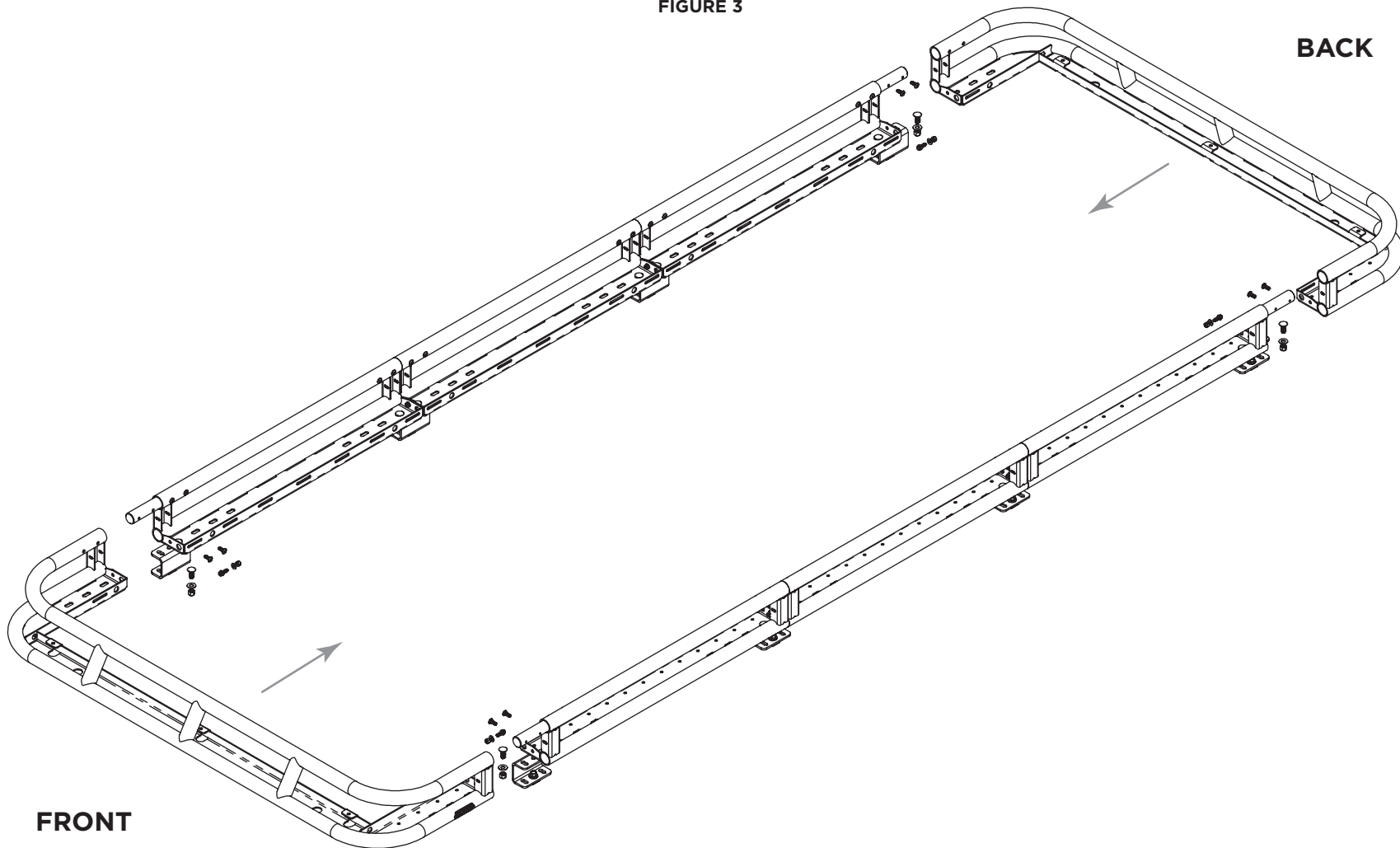

6. ONCE YOU'VE GOT BOTH ENDS TIGHTENED; IT'S TIME TO START LAYING DOWN YOUR CROSSBARS. WE'VE PROVIDED DIMENSIONS BELOW IN **FIGURE 4** TO MAKE IT EASY. MAKE SURE YOU VERIFY THE DIMENSION ON BOTH ENDS OF THE CROSSBAR RELATIVE TO THE **REFERENCE POINT** TO ENSURE THEY ARE SQUARE. THIS WILL MAKE IT MUCH EASIER WHEN MOUNTING YOUR DECKING PANELS LATER. THE DIMENSIONS ARE PULLED FROM THE FLANGE ON THE TRAY OF THE REAR BASKET TO THE FRONT FACE OF THE CROSSBAR (FURTHEST SIDE) **WAIT TO TIGHTEN THE CROSSBARS UNTIL YOU HAVE PUT ALL OF THEM IN.**

**NOTE-** REMEMBER TO LEAVE THE RAIL MOUNT FEET LOOSENED. WE'LL TIGHTEN THOSE DOWN IN A LATER STEP.

DETAIL E

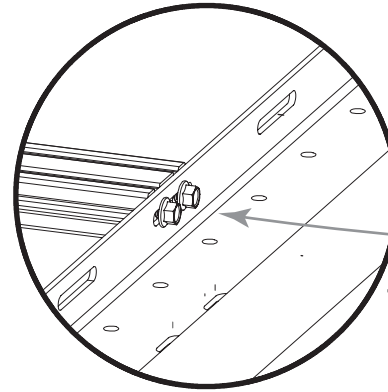

1/4-20 X 0.75 FLANGED HEX HEAD SCREW

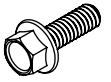
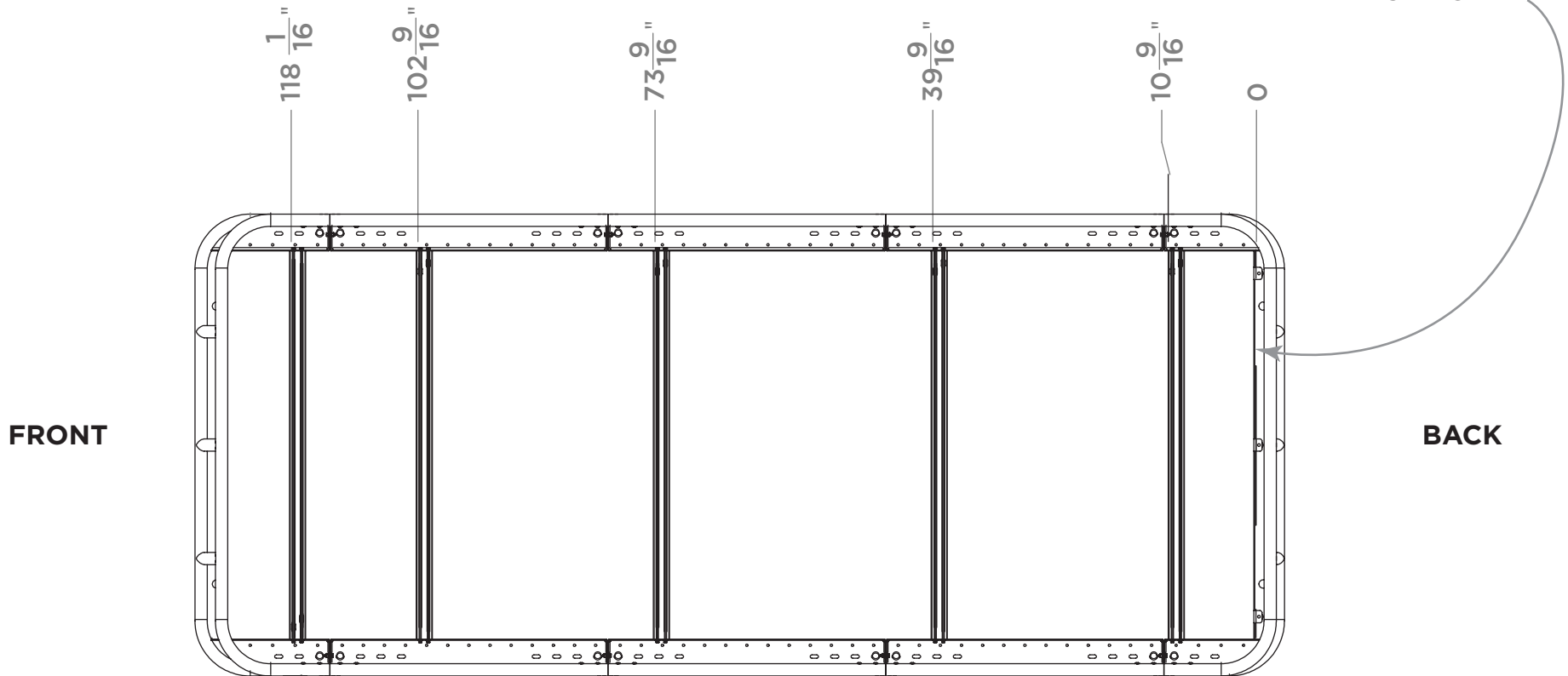

FIGURE 4

REFERENCE POINT



# AWNING MOUNTS

7. THIS STEP IS ONLY NECESSARY IF YOU ARE MOUNTING A FIAMMA F45 (OR SIMILAR) AWNING TO YOUR SAFARI RACK. IF YOU ARE NOT MOUNTING AN AWNING, SKIP TO STEP 8. YOU WILL MOUNT THE 3 **AWNING BRACKETS** TO THE UNDERSIDE OF THE PASSENGER SIDE OF THE RACK AS SHOWN IN **DETAIL F** TO THE RIGHT. THE LOCATIONS ARE SHOWN BELOW IN **FIGURE 5** AND USE THE SAME REFERENCE POINT AS THE CROSSBARS. THESE BRACKETS SHOULD BE TIGHTENED ONCE ATTACHED TO THE RACK USING THE SAME HARDWARE SET AS THE RAIL MOUNTS.

**NOTE-** THE DIMENSIONS GIVEN ARE SUGGESTED BASED ON OPTIMAL SUPPORT LOCATIONS. THESE MAY DIFFER IF USING A SMALLER OR LARGER AWNING THAN TYPICAL, AND ADDITIONAL MOUNT SLOTS ARE AVAILABLE TO SUIT YOUR NEEDS.

THE AWNING BRACKETS HAVE SLOTS FOR MINOR ADJUSTMENT.

DETAIL F

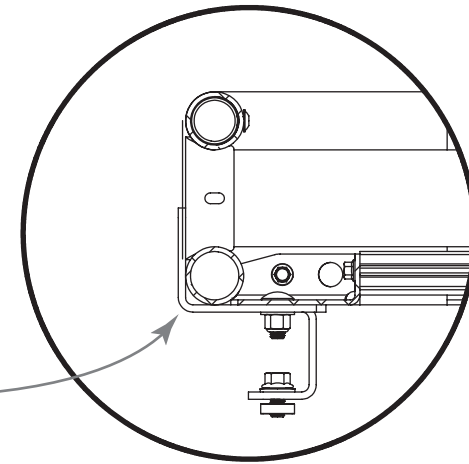

AWNING BRACKET

FIGURE 5

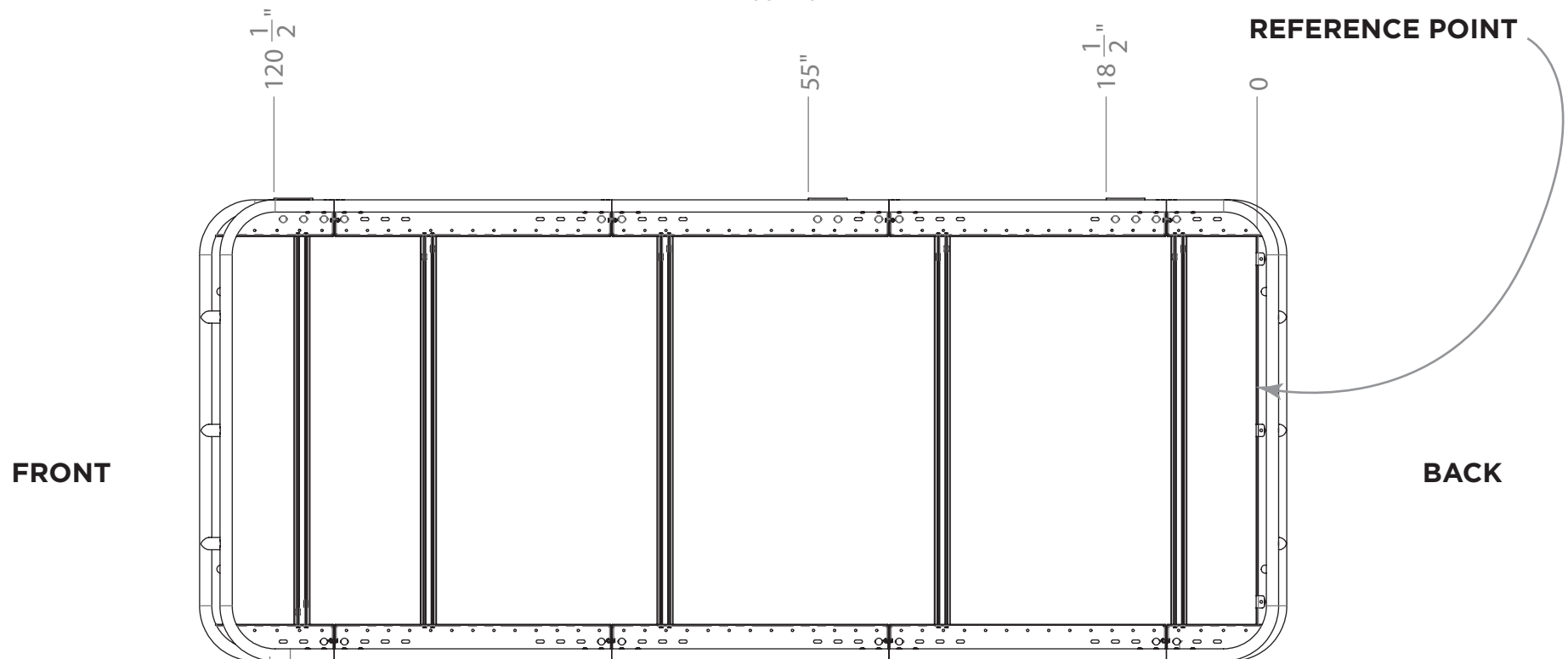

8. BEFORE MOVING ONTO THE FLOOR SECTIONS; NOW IS THE TIME TO CENTER THE RACK ON YOUR VAN AND TIGHTEN THE RAIL MOUNTS, BOTH TO THE VAN, AND TO THE RACK. ONCE YOU FINISH THAT; WE CAN PROCEED TO ATTACHING THE FLOOR SECTIONS.

9. START WITH THE REAR FLOOR SECTION FIRST AND WORK YOUR WAY UP. **IMPORTANT-** THE FRONT AND REAR SECTIONS LOOK VERY SIMILAR. TO TELL THEM APART; THE REAR SECTION WILL MEASURE ROUGHLY 12" LONG, WHILE THE FRONT MEASURES ROUGHLY 11.25". INSERT THE HARDWARE INTO THE SLOT ON THE CROSSBAR AS SHOWN IN **DETAIL G** TO THE RIGHT, THEN ALIGN THEM USING YOUR ALLEN KEY AS SHOWN IN **DETAIL H**. **DETAIL J** SHOWS A SECTION VIEW OF HOW THE FASTENERS ATTACH THE END FLOOR SECTIONS TO THE TRAY OF THE BASKET WELDMENTS WHERE NO CROSSBARS ARE PRESENT TO ATTACH TO. **FIGURE 6** ON THE NEXT PAGE SHOWS PANEL LOCATIONS. ALIGNMENT IS KEY HERE TO ACHIEVE A HIGH QUALITY END RESULT, SO USE YOUR EYES TO ALIGN THE PANELS STRAIGHT WITH THE CROSSBARS. THE MOUNTING SLOTS HAVE A WIDE RANGE TO ACCOUNT FOR ANY MISALIGNMENT THAT MAY HAVE OCCURRED DURING ASSEMBLY OF THE RACK.

**NOTE-** WE RECOMMEND APPLYING BLUE LOCTITE (OR SIMILAR THREADLOCKER) TO THE SCREWS THAT HOLD THE FLOOR SECTIONS DOWN TO THE CROSSBARS TO ENSURE THEY DO NOT COME LOOSE WHILE DRIVING. THIS IS NOT NECESSARY ON FRONT AND REAR BOLTS WITH NYLOCK NUTS.

DETAIL G

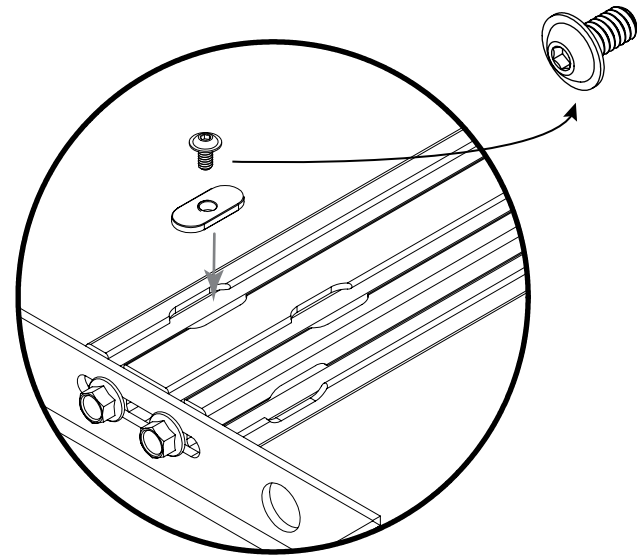

1/4-20 X 0.75 FLANGED BUTTON HEAD  
HEX DRIVE SCREW

DETAIL J

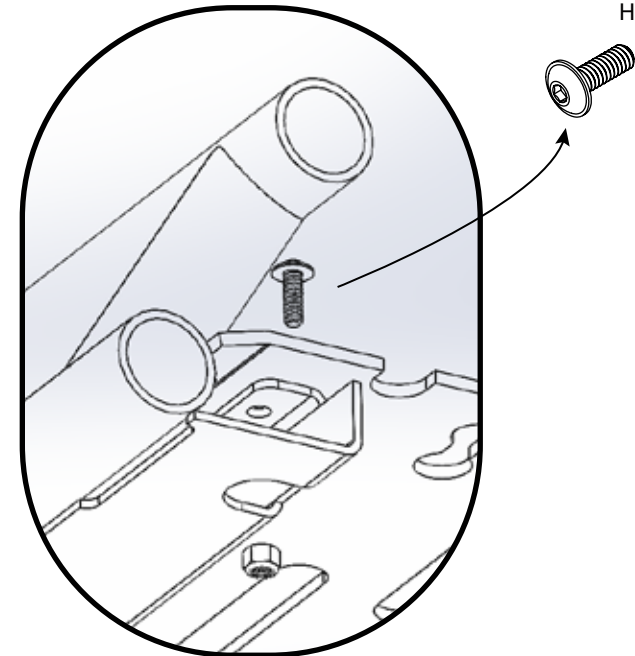

1/4-20 X 0.75 FLANGED BUTTON HEAD  
HEX DRIVE SCREW

DETAIL H



- FLOOR SECTION 6
- FLOOR SECTION FAN SIDE PANEL
- FLOOR SECTION FAN COVER
- FLOOR SECTION 4
- FLOOR SECTION 2
- BASKET FRONT FLOOR SECTION

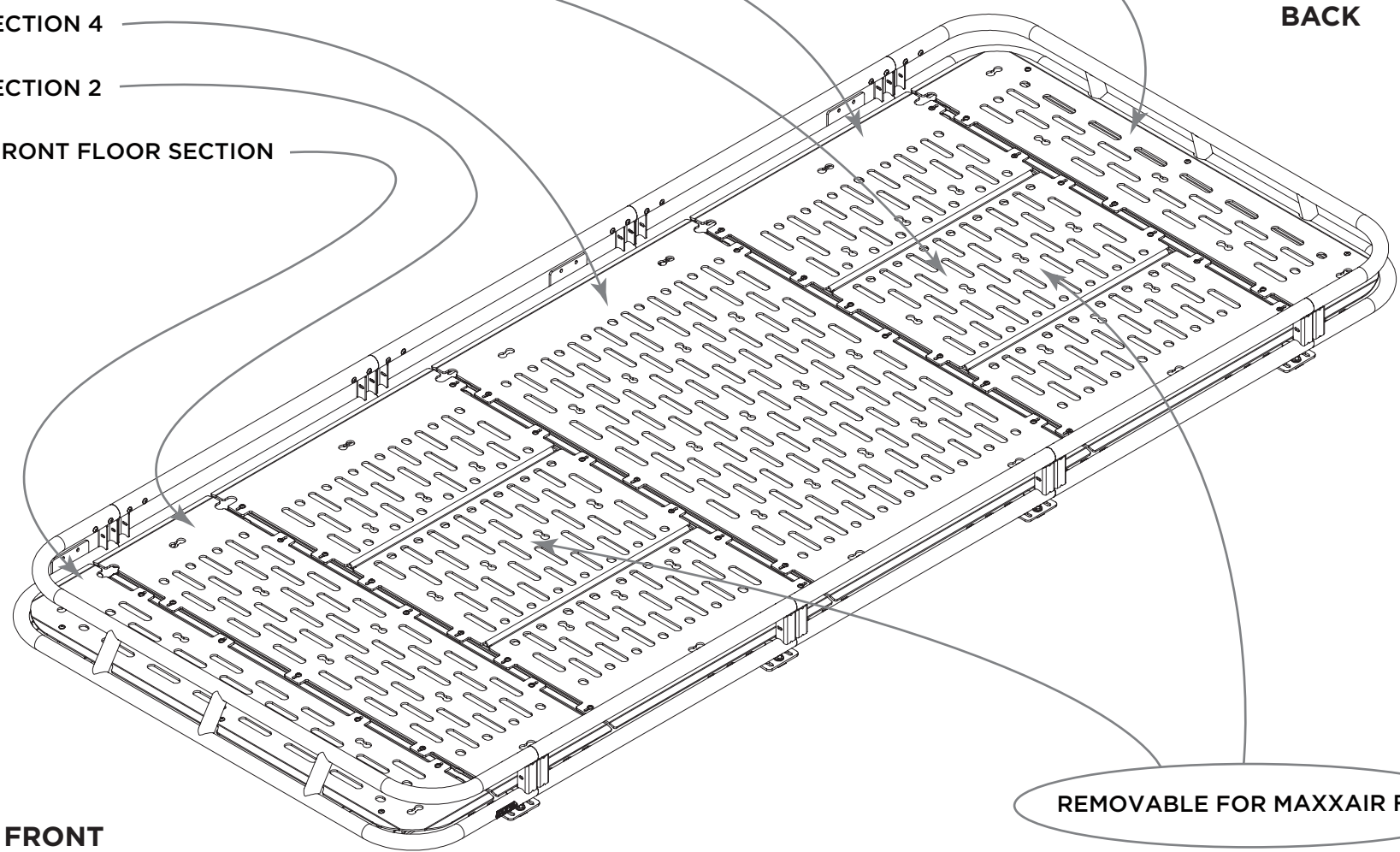

**BACK**

**FRONT**

**REMOVABLE FOR MAXXAIR FAN**

10. ONCE YOU'VE GOT ALL OF THE FLOOR SECTIONS BOLTED DOWN, DO A ONCE OVER OF ALL FASTENERS ON THE RACK TO ENSURE THEY ARE TIGHT AND SECURE. INSTALL IS NOW COMPLETE, AND YOU'RE READY FOR ADVENTURE!

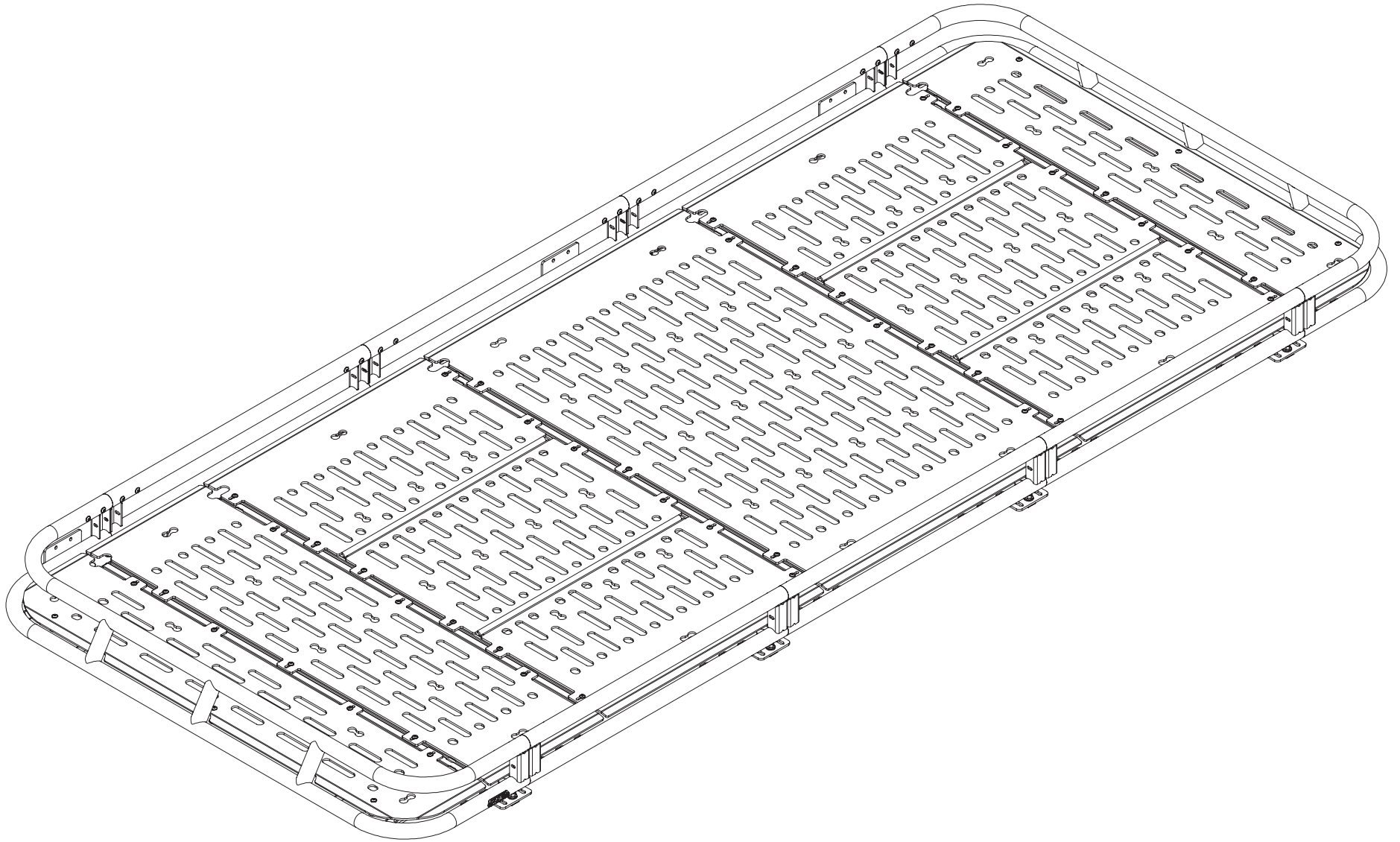

# GET OUT AND EXPLORE!

## LEAVE US A REVIEW

Happy with your new FVC product? We would love to hear (and see) from you! Head to the product page and click "Leave Review." Add a short review and upload a few photos to be showcased on the product page.

## SHARE YOUR PHOTOS WITH US

We love seeing how our customers use their FVC products and following along with your adventures. Tag us in your photos with @flatlinevanco or send them to us via email. We love posting customer pictures in our feed!

## CUSTOMER SUPPORT

If you are having any issues with your product, please reach out, and we will make it right. FVC is a company of van and outdoor enthusiasts that design and use our own products, so we want you to be as stoked on your new parts as we are!



**@flatlinevanco**



**facebook.com/flatlinevanco**



**youtube.com/c/flatlinevanco**



**support@flatlinevanco.com**



**thanks!**