

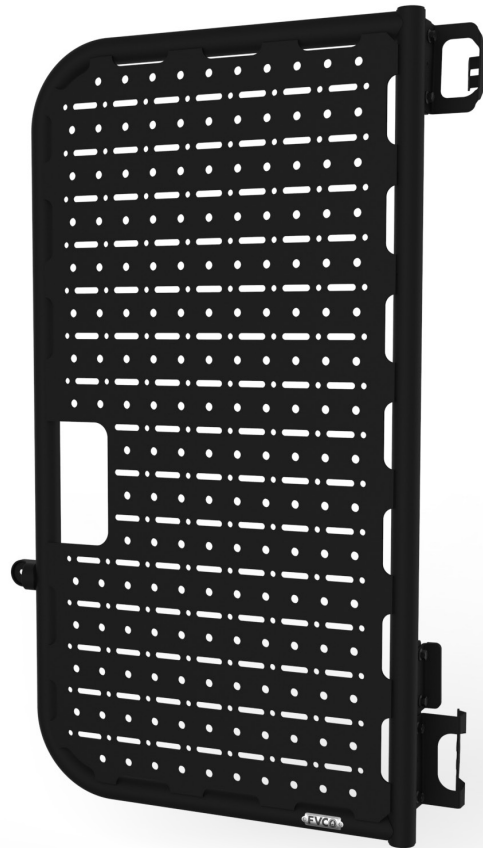

INSTALLATION GUIDE

PROMASTER VAN REAR DOOR PLATFORM - PASSENGER'S SIDE

PM1104B



TOOLS REQUIRED (NOT INCLUDED)

- | | |
|---------------------------|------------------------|
| + AUTO PANEL REMOVAL TOOL | + 5/32" ALLEN WRENCH |
| + PAINTER'S TAPE | + 7/32" ALLEN WRENCH |
| + MEASURING TAPE | + MARKER |
| + POWER DRILL | + T40 TORX |
| + 3/16" DRILL BIT | + FLATHEAD SCREWDRIVER |
| + 27/64" DRILL BIT | + 4MM ALLEN WRENCH |
| + DEBUR TOOL | + 5MM WRENCH/SOCKET |
| + RUST PREVENTATIVE PAINT | + MEASURING TAPE |
| + 9/16" WRENCH/SOCKET | |

INSTALL INFO

TIME TO INSTALL THIS PRODUCT: 1-2 HOURS

Additional help is suggested for a few of the install steps.

BEFORE YOU START

Please inspect the product and packaging upon delivery to ensure there are no issues and that all parts and hardware are accounted for.

Contact us ASAP if anything is missing at:
support@flatlinevanco.com

BEFORE YOU START

All Flatline Van Co products must be properly assembled and secured before attaching to your vehicle. Improper attachment could result in an automobile accident, and could cause serious bodily injury or death to you or to others involved. You are responsible for assembling and securing Flatline Van Co products to your vehicle, checking the mounting points and attachments prior to use, and regularly inspecting the products for wear and or damage. We always recommend you use a professional to install any aftermarket accessories to your vehicle. If you have no mechanical experience and are not thoroughly familiar with the installation procedures, you must have the product installed by a professional installer or other qualified persons. The responsibility is yours and must be taken seriously for everyone's safety.



PACKAGE CONTENTS

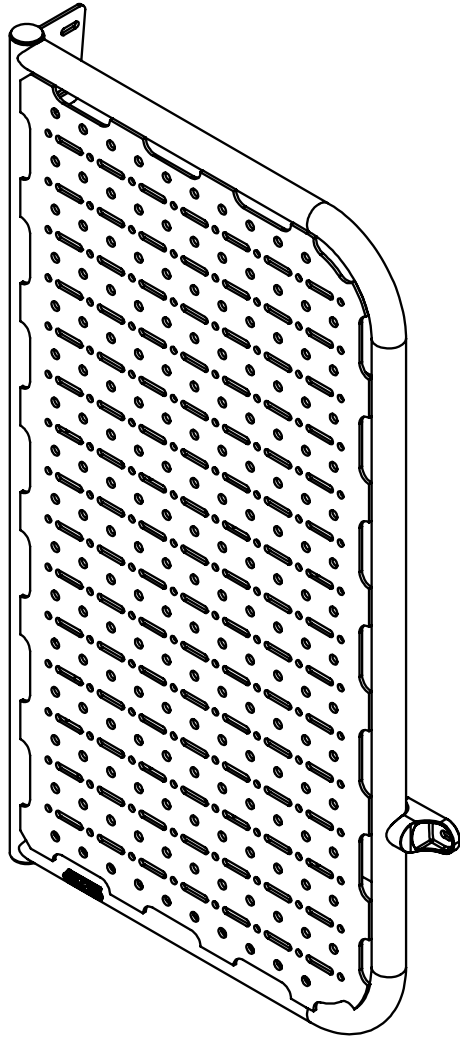

REAR DOOR PLATFORM

QTY: 1

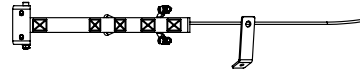

LIMIT STRAP ASSEMBLY

QTY: 1



BOTTLE OPENER

QTY: 1

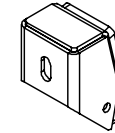

BOTTLE OPENER

QTY: 1

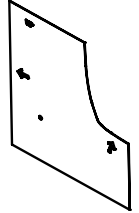

DRILL TEMPLATE

QTY: 1

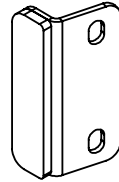

FRAME BRACE

QTY: 1



LOWER HINGE BRACKET

QTY: 1

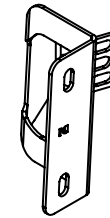

UPPER HINGE BRACKET

QTY: 1

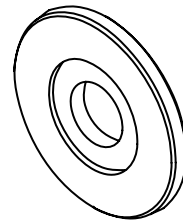

BUSHING CAP

QTY: 1

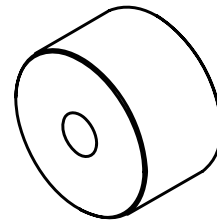

TALL BUSHING

QTY: 1

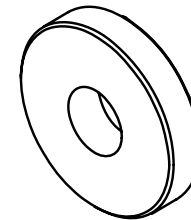

SHORT BUSHING

QTY: 1

HARDWARE

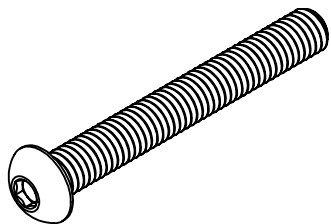

3/8-16 X 2.25 BUTTON
HEAD HEX DRIVE SCREW

QTY: 1

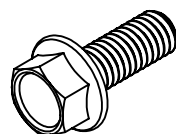

3/8-16 X 1 FLANGED HEX
HEAD SCREW

QTY: 6

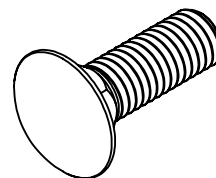

3/8-16 X 1.25 SQUARE NECK
CARRIAGE BOLT

QTY: 1



1/4-20 X 0.75 FLANGED
BUTTON HEAD HEX DRIVE
SCREW

QTY: 2



3/8-16 NYLON LOCKNUT

QTY: 8



3/8 FLAT WASHER

QTY: 8

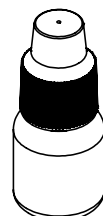

THREAD LOCKER

QTY: 1

INSTALL

TOOLS REQUIRED FOR THIS STEP: + AUTO PANEL REMOVAL TOOL

STEP | 01 LAYOUT AND INSTALL PREP

1.1 Door Panel Removal: Remove the Lower Panel Trim (FIG 1) using plastic panel removal tools. Be gentle to avoid breaking the factory panel clips. If clips get stuck in the door, pop them out and slide them back into place on the trim panel.

NOTE- You may have any number of different door configurations- stock full trim, stock half trim, stock panel (Pictured FIG 1), upholstered wood, etc. Each require their own removal method.

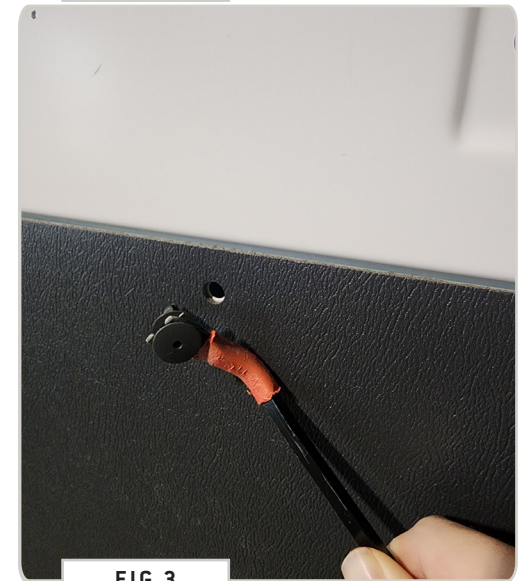
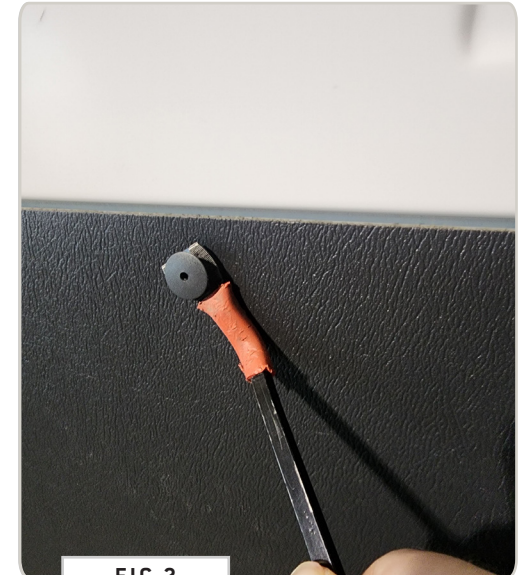
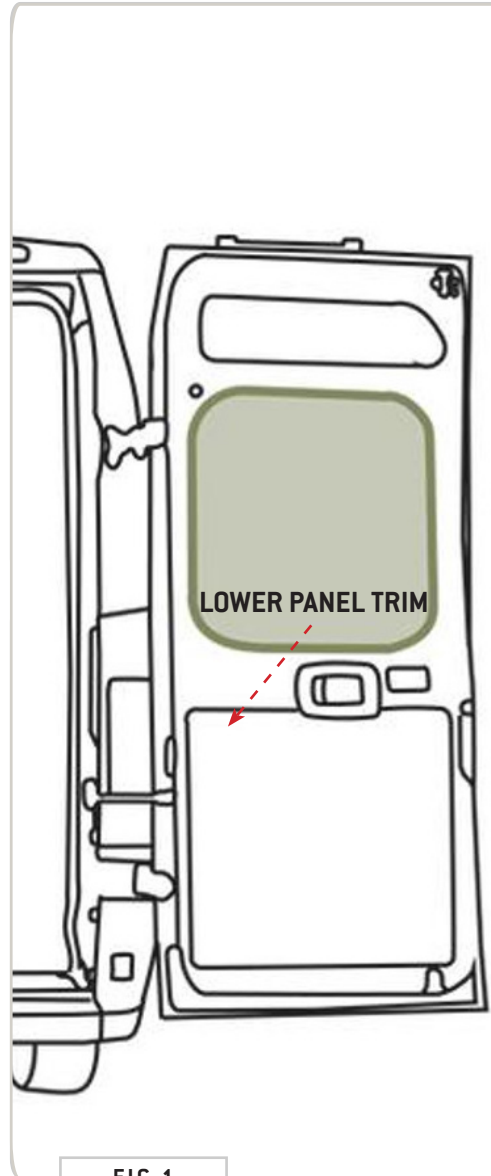

TOOLS REQUIRED FOR THIS STEP:

| | | | |
|---|-----------------|---|-------------------------|
| + | MARKER | + | 27/64" DRILL BIT |
| + | POWER DRILL | + | METAL FILE |
| + | 3/16" DRILL BIT | + | RUST PREVENTATIVE PAINT |

STEP | 02 DRILL FOR THIRD MOUNT

2.1 Marking Front Drill Location: Use the **Front Drill Template** to mark the outside of the rear passenger door. The arrow should align with the **Left Side Of The Door** and **Left Side Of The Grab Handle** as shown in FIG 4+5.

NOTE - *The template aligns to the contours of the van body's sheet metal and not the plastic trim of the Grab Handle. Be sure to keep the template tight against the van body.*

2.2 Drill Front-Facing Third Mount: Drill out your mark with a **Pilot Bit** (3/16" sized or similar), then enlarge it with a **27/64" Drill Bit**.

2.3 Paint Raw Edges: Debur and paint the exposed edges for rust prevention.



FIG 4



FIG 5

TOOLS REQUIRED FOR THIS STEP: + T40 TORX
+ MARKER
+ SCREWDRIVER

STEP | 03 INSTALL VAN MOUNTS

3.1 Bottom Hinge Alignment Marks: Begin by marking alignment points at the bottom hinge of the passenger-side door (FIG 6).

3.2 Release Bottom Hinge: Remove the three factory bolts of the lower hinge using a T40 Torx (FIG 7).

NOTE - *Be very careful not to strip the head of the bolts. Do not use power tools! Very easy to cross thread!!*

3.3 Position P2 Hinge Bracket: Support the door while swinging the hinge back to slide the **P2 Hinge Bracket** over it (FIG 8).

3.4 Secure P2 Hinge Bracket Reinstall the factory bolts snugly, then check clearances by slowly closing the door before tightening the bolts (FIG 9).

PRO-TIP: *Use a punch or screwdriver inside one of the threaded holes to keep the door aligned while you thread them in to avoid cross-threading.*

3.5 Repeat for P1 Hinge Bracket: Repeat the process for the upper hinge with the **P1 Hinge Bracket**. Ensure the door is supported to prevent twisting during hinge removal. After installing the **P1 Hinge Bracket**, test door function to ensure there is no contact with the van's body during operation.



FIG 6



FIG 7



FIG 8



FIG 9

TOOLS REQUIRED FOR THIS STEP: + 9/16" WRENCH/SOCKET

STEP | 03 INSTALL VAN MOUNTS

3.6 Third Mount: Install the Third Mount to the drilled hole using a 3/8" Carriage Bolt, Bungee Bracket, 3/8" Flat Washer and Nylon Locknut (FIG 10-12).

NOTE - Make sure that the **Bungee Bracket** is in the orientation as shown in FIG 12.

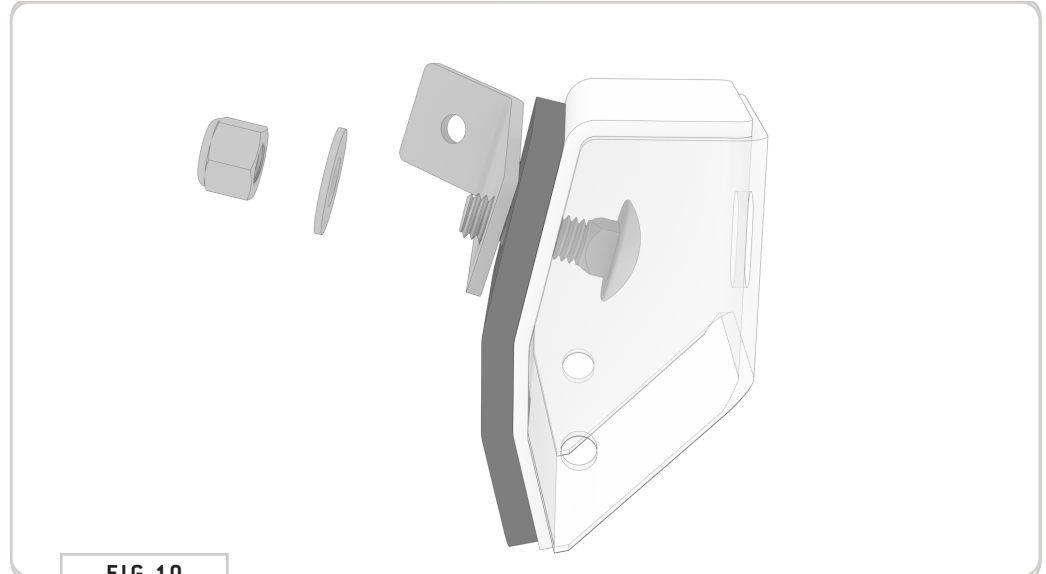

FIG 10

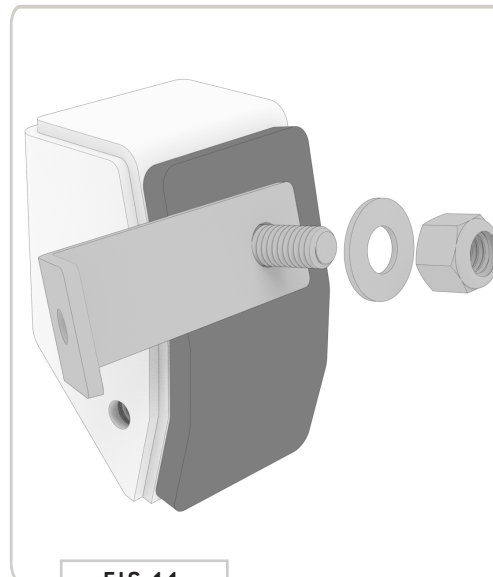

FIG 11



FIG 12

TOOLS REQUIRED FOR THIS STEP: + 9/16" WRENCH/SOCKET
+ 7/32" ALLEN WRENCH

STEP | 04 INSTALL PLATFORM

4.1 Hinge Mounts: With assistance, raise the Platform up to the door and insert (2ea) 3/8" Flanged Hex Head Screws through the Upper (FIG 13) and Lower (FIG 14) Hinge Brackets. Loosely thread on (2ea) 3/8" Flat Washers and Nylon Locknuts.

NOTE - Use extreme caution around factory rear windows while mounting Platform into position.

NOTE - Make sure that the "fins" of the Platform are on the inside of the Hinge Brackets as shown in FIG 13 and 14.

4.2 Third Mount: Insert the Bushing Assembly through the Third Mount Bracket Hole to center the Platform and secure using a 3/8" Flat Washer and Nylon Locknut. (FIG 15).

4.3 Lower Frame Brace: Use a 9/16" Wrench and Socket to attach the lower frame brace tightly to the door using (2ea) 3/8" Flanged Hex Head Screws and (2ea) 3/8" Flat Washers and Nylon Locknuts (FIG 14).

4.4 Checking Clearance: Ensure the third mount is secure, then operate the door to check for interference with mount brackets. If everything is lining up, tighten down all fasteners on the hinge mounts.

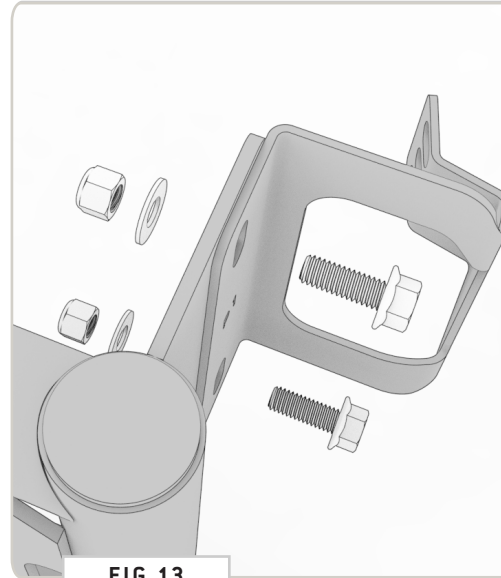

FIG 13

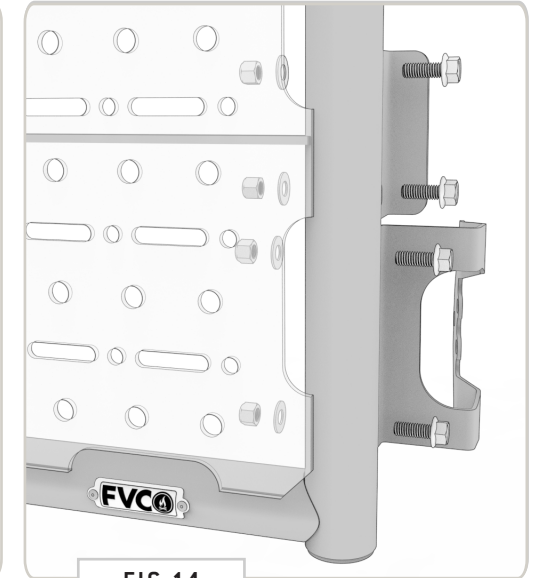

FIG 14

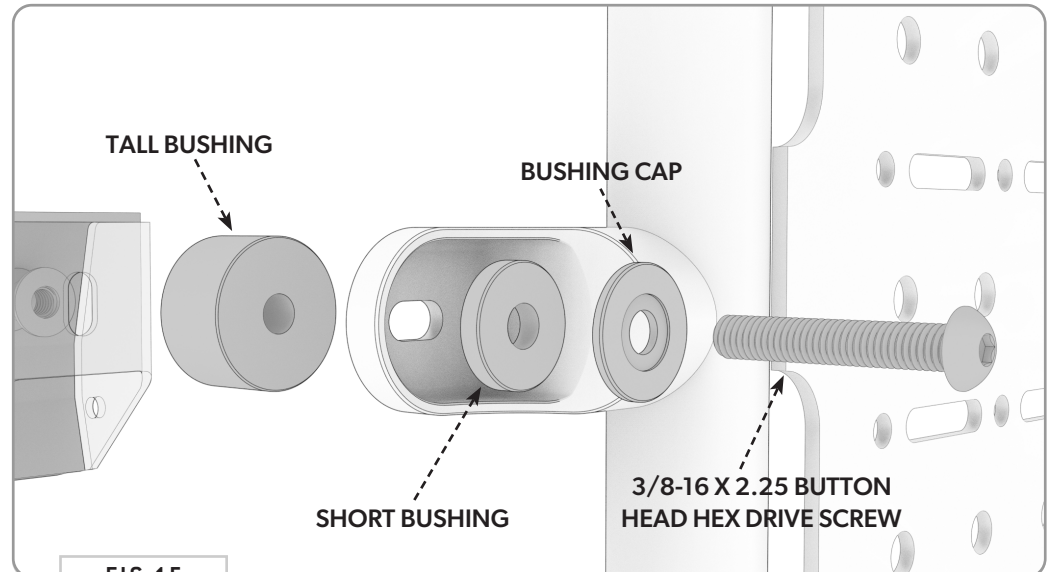

FIG 15

TOOLS REQUIRED FOR THIS STEP: + FLATHEAD SCREWDRIVER
+ 4MM ALLEN WRENCH
+ 5MM WRENCH/SOCKET

STEP | 05 INSTALL LIMIT STRAP

5.1 Remove Factory Cap and Sticker Covers: Use a flathead screwdriver to remove the factory plastic cap along the inside of the door (FIG 16) and the stickers that cover the threaded holes of the van body (FIG 17).

5.2 Layout Limit Strap Components: Notice the components of the **Limit Strap Assembly** in FIG . You will first need the **Limit Strap Bracket** in the next step.

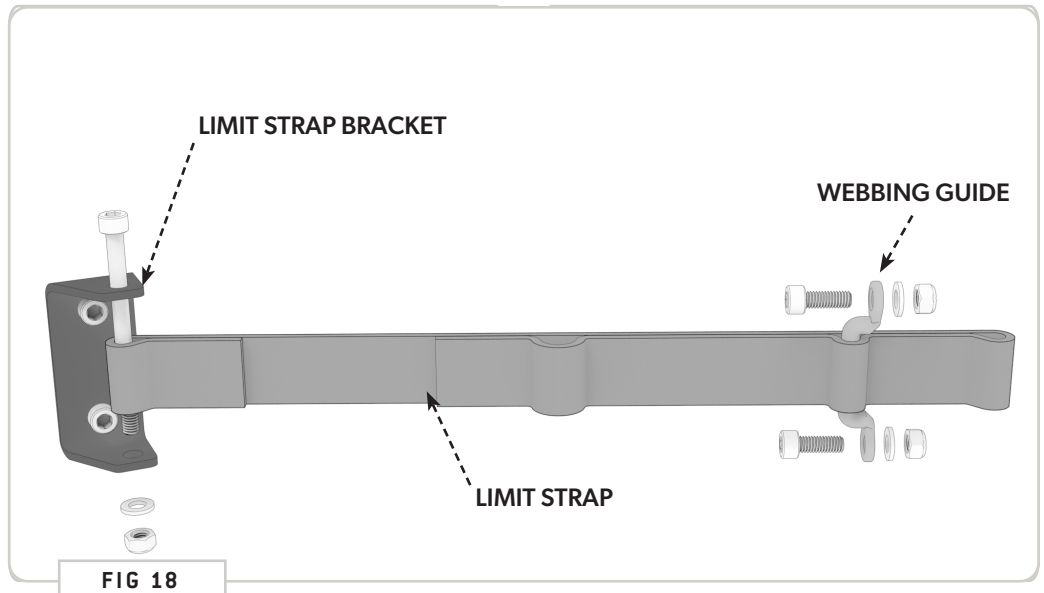
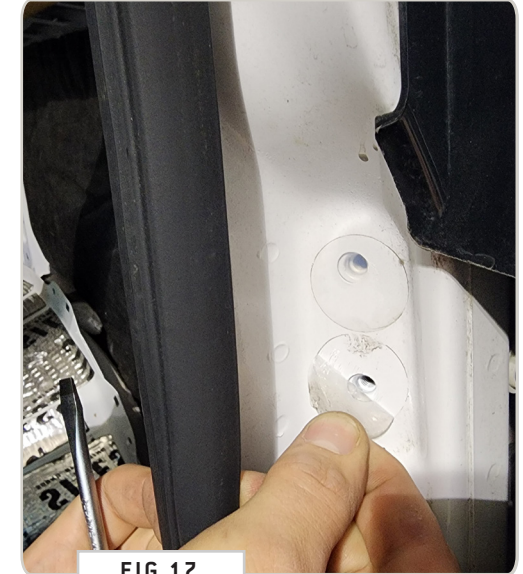

TOOLS REQUIRED FOR THIS STEP: + 4MM ALLEN WRENCH
+ 5MM WRENCH/SOCKET

STEP | 05 INSTALL LIMIT STRAP

5.3 Attach Limit Strap to Bracket: Attach the **Limit Strap Webbing** to the **Limit Strap Bracket** using the **longest M6 Socket Head Screw, Flat Washer and Nylon Locknut** (if it isn't attached already).

NOTE - Note the middle loop of the webbing is facing inward for bungee.

5.4 Install Limit Strap Bracket: Install the **Limit Strap Bracket** to the threaded locations on the inside of the door jam using the supplied **M6 Socket Head Screws (FIG 19)**.

5.5 Install Webbing Guide: Attach **Limit Strap** to the **Webbing Guide** (if it isn't already) and install to the van in the location shown in **FIG 20** using **(2ea) M6 Socket Head Screws, Flat Washers and Nylon Locknuts (FIG 21)**.



FIG 19

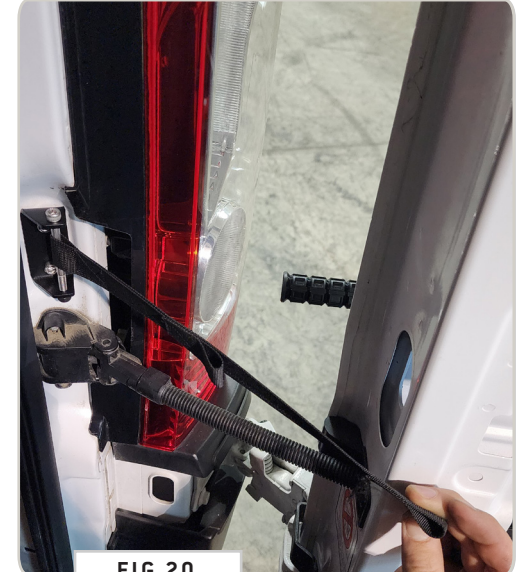

FIG 20



FIG 21



FIG 22

STEP | 05 INSTALL LIMIT STRAP

5.6 Layout Limit Strap Retraction Bungee: Run the **Limit Strap Retraction Bungee** through the sewn loop in the middle of the **Limit Strap** and tie off using an **Figure 8 Knot** (or similar) at about 14" long (**FIG 23**).

5.7 Tie to Bungee Bracket: Run the **Limit Strap Retraction Bungee** through the **Bungee Bracket**, pull until tight and tie off using a standard **Overhand Knot** (**FIG 24**).



FIG 23



FIG 24

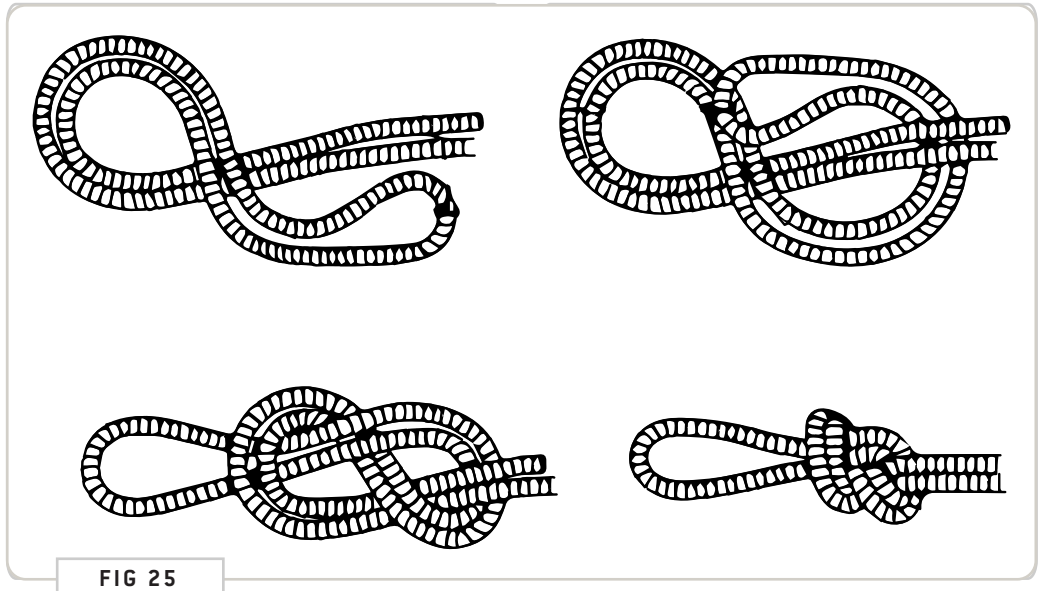

FIG 25

STEP | 06 FOOT PEGS & BOTTLE OPENER

6.1 Bottle Opener: Attach the **Bottle Opener** to the **Third Mount Bracket** using (2) 1/4-20 x 0.75 Flanged Button Head Screws (FIG 26+27).

TOOLS REQUIRED FOR THIS STEP: + LOCTITE
+ 5/32" ALLEN WRENCH

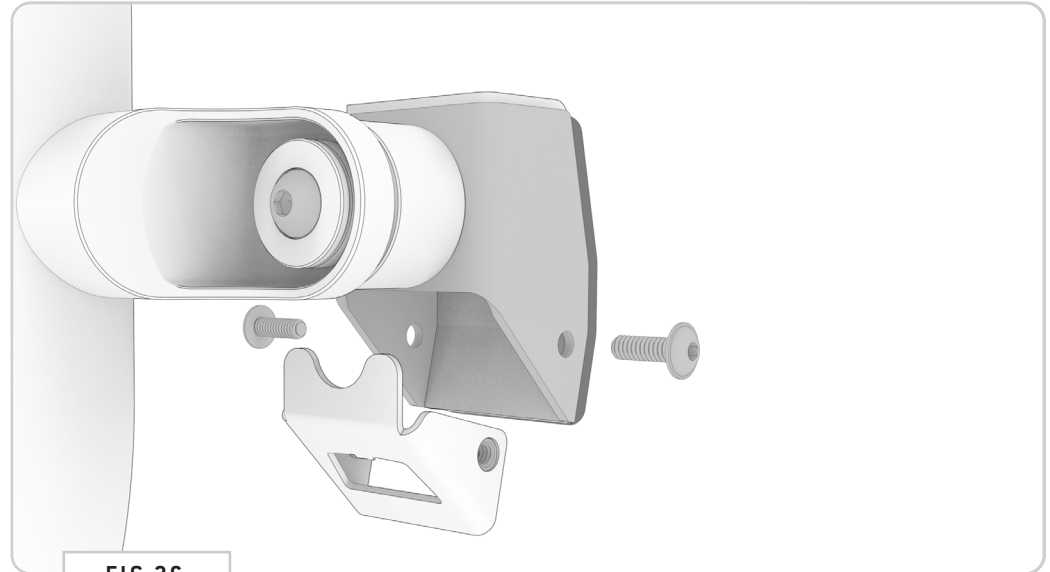

FIG 26

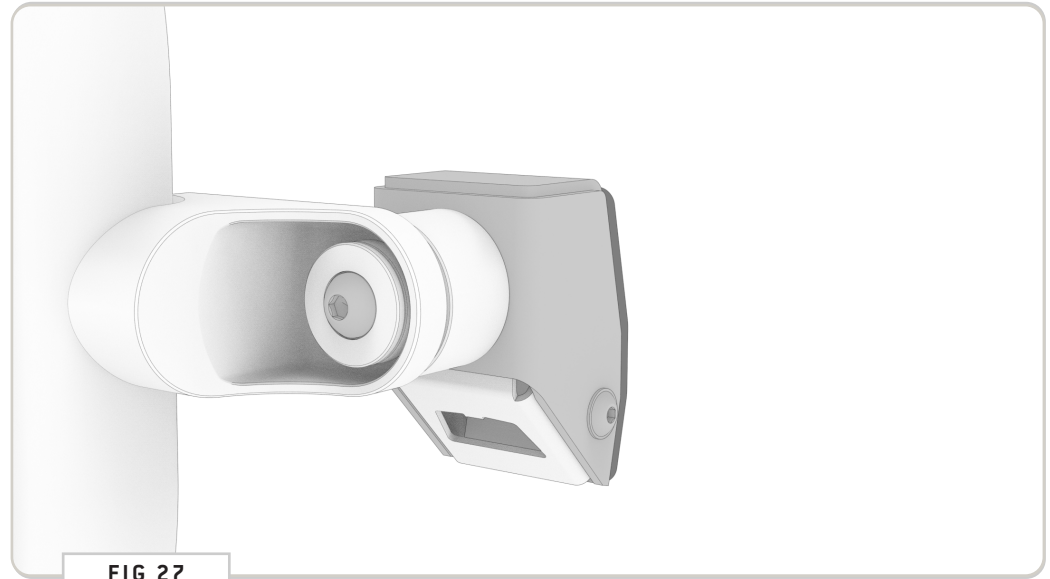

FIG 27

GET OUT AND EXPLORE!

+ LEAVE US A REVIEW

Happy with your new FVC product? We would love to hear (and see) from you! Head to the product page and click "Leave Review." Add a short review and upload a few photos to be showcased on the product page.

+ SHARE YOUR PICS

We love seeing how our customers use their FVC products and following along with your adventures. Tag us in your photos with: @flatlinevanco or send them to us via email. We love posting customer pictures in our feed!

+ NEED ANY HELP?

If you are having any issues with your product, please reach out, and we will make it right. FVC is a company of van and outdoor enthusiasts that design and use our own products, so we want you to be as stoked on your new parts as we are!



@FLATLINEVANCO